

## **Activation of Oxygen Generators in Proximity to Combustible Materials**

May 1999

DOT/FAA/AR-TN99/9

This document is available to the public through the National Technical Information Service (NTIS), Springfield, Virginia 22161.



U.S. Department of Transportation  
Federal Aviation Administration



- PSS002461R-04 -

## NOTICE

This document is disseminated under the sponsorship of the U.S. Department of Transportation in the interest of information exchange. The United States Government assumes no liability for the contents or use thereof. The United States Government does not endorse products or manufacturers. Trade or manufacturer's names appear herein solely because they are considered essential to the objective of this report. This document does not constitute FAA certification policy. Consult your local FAA aircraft certification office as to its use.

This report is available at the Federal Aviation Administration William J. Hughes Technical Center's Full-Text Technical Reports page: [www.tc.faa.gov/its/act141/reportpage.html](http://www.tc.faa.gov/its/act141/reportpage.html) in Adobe Acrobat portable document format (PDF).



1. Report No. DOT/FAA/AR-TN99/9		2. Government Accession No.		3. Recipient's Catalog No.	
4. Title and Subtitle ACTIVATION OF OXYGEN GENERATORS IN PROXIMITY TO COMBUSTIBLE MATERIALS				5. Report Date May 1999	
				6. Performing Organization Code	
7. Author(s) Thomas R. O'Connor and Eric L. Hagen*				8. Performing Organization Report No.	
9. Performing Organization Name and Address Fire Safety Research and Development Federal Aviation Administration William J. Hughes Technical Center Atlantic City International Airport, NJ 08405				10. Work Unit No. (TRAIS)	
				11. Contract or Grant No.	
12. Sponsoring Agency Name and Address U.S. Department of Transportation Federal Aviation Administration Office of Aviation Research Washington, DC 20591				13. Type of Report and Period Covered Technical Note	
				14. Sponsoring Agency Code AAI-100	
15. Supplementary Notes *Galaxy Scientific Corporation					
16. Abstract  This report presents the results of a series of tests performed on oxygen generators contained in cardboard shipping containers and packing materials to witness the probability of ignition in the event one of the generators was activated. Test results indicated that in the presence of an activated generator, combustible materials will produce a fire.					
17. Key Words Combustible material, Activate sodium chlorate core, Ignition, Oxygen generators, Canisters				18. Distribution Statement This document is available to the public through the National Technical Information Service (NTIS) Springfield, Virginia 22161.	
19. Security Classif. (of this report) Unclassified		20. Security Classif. (of this page) Unclassified		21. No. of Pages 20	22. Price



## TABLE OF CONTENTS

	Page
EXECUTIVE SUMMARY	v
INTRODUCTION	1
Purpose	1
Background	1
Design Features	1
Test Configurations	1
Test Setups and Results	1
Test 1	1
Test 2	2
Test 3	2
Test 4	2
Test 5	4
Test 6	4
Test 7	4
Test 8	4
Test 9	4
Test 10	5
Test 11	5
Test 12	5
Test 13	6
Test 14	6
Test 15	6
Test 16	6
Test 17	6
Test 18	7
Test 19	7
Test 20	7
Test 21	7
Test 22	9
Test 23	9
Test 24	9
Test 25	12
Test 26	12
Test 27	12
CONCLUDING REMARKS	14

## LIST OF ILLUSTRATIONS

Figure		Page
1	Generator Being Placed in a Cardboard Container	2
2	Generator Packaging Ignited After the Generator was Activated	3
3	Test Results After Three Thermocouples Were Safety Wired to the Side of a Generator	3
4	Test Results After Three Thermocouples Were Held Against the Surface of a Scott 801386-05 Generator With Screws	4
5	Generators Overpressurized After Plugging the Outlets and Activated	5
6	Melted Generators	6
7	Temperature of Flames Being Measured With a Pyrometer	7
8	Test Results After Six Generators Were Packed in Tubes and the Tubes Packed in a Box and Activated	8
9	Thermocouple Spot Welded to the Side of a Three-Person Generator	8
10	Results of the Spot-Welded Generator Test	9
11	Three Generators Placed in a Tin Can	10
12	Test Results After Six Generators Were Packed in Tubes and Packed in a Box and the Box Placed on its Side	10
13	Generator Packed in Noncombustible Material	11
14	Generators After Activation and Removed From Box	11
15	Electrically Activated Generator With Heat Shield and Melted Bubble Plastic	12
16	Disassembled Generator	13
17	Cutaway View of Electrically Activated Generator	13



## EXECUTIVE SUMMARY

This study was undertaken to determine whether combustible materials could be ignited by placing them near an activated oxygen generator, determine if that fire could activate other unactivated generators, and examine the intensity of any oxygen-fed fires. Since a packed box can be shipped on any side, tests were performed in a variety of configurations. A 2000°F propane fire was used to ascertain if it could ignite an unactivated generator and 27 tests were conducted to determine whether combustible materials can be ignited by an activated generator and if that the fire can activate other generators.

Tests conducted in this report demonstrate that a generator activated in a confined space may ignite adjacent combustible material due to the hot surface and elevated oxygen concentration. This was shown with cylindrical cardboard shipping containers with urethane foam pads and with cardboard boxes with bubble plastic shipping material. In addition, the initial fire involving burning combustible material will cause additional generators to activate, creating an intense fire associated with burning in an oxygen-enriched environment and reach temperatures above 2700°F. Means of shipping or storing generators to prevent a fire in the event that a generator is accidentally activated were demonstrated.



## INTRODUCTION

### PURPOSE.

The purpose of this report is to summarize the data collected in a variety of tests performed on several different types of oxygen generators that are used on large aircraft to determine the ability of the activated generators to ignite fires in nearby combustible material and whether or not unactivated generators can be activated in those fires.

### BACKGROUND.

On May 11, 1996, an on-board fire caused a DC-9 to crash into the Everglades northwest of Miami International Airport. Numerous oxygen generators were on board as cargo. These generators have a shelf life after which they must be removed from the overhead compartments and replaced. The shipped generators on this flight had been removed from two MD-80 aircraft, due to exceeded expiration dates, and were being transported to Atlanta for disposal. They were packaged loose in cardboard boxes with plastic bubble pack between the generators and the top of the box. These tests were conducted to see if the DC-9 fire could have been caused by the inadvertent activation of one of these oxygen generators.

### DESIGN FEATURES.

The oxygen generators are designed to produce pure oxygen. This is done by igniting a solid core of sodium chlorate inside the stainless steel canister. The core will take approximately 15 minutes to burn and produce oxygen. While burning, the core will build up heat and will produce small quantities of carbon monoxide (CO) and carbon dioxide (CO<sub>2</sub>). Since the core is inside the stainless steel canister and not exposed to atmospheric air, there is very little or no smoke. In normal operation these gases are filtered chemically allowing only oxygen to pass through. The oxygen produced by the generators is transferred through an outlet port, and a separate port provides for pressure relief.

### TEST CONFIGURATIONS.

Several oxygen generators were set off in a variety of conditions simulating how they might be shipped. Methods of packaging included polyurethane foam end caps and cardboard tubes and loose generators with bubble pack in cardboard boxes. Since a packed box can be shipped on any side, tests were performed in a variety of configurations. To simulate an existing fire, inactivated generators were placed in a 2000°F propane fire. Since it is conceivable that the sodium chlorate in an inactivated generator could melt and plug all outlets, the outlet and pressure relief valves were plugged before activating the generator to simulate this melting situation.

### TEST SETUPS AND RESULTS.

TEST 1. A generator was placed with the oxygen outlet up in a propane burner fire for 15 minutes. After approximately 1 to 2 minutes, sparks emerged from the outlet end of the generator. The generator produced oxygen from the outlet end for a short period of time,

approximately one minute, then stopped. After approximately six minutes, the generator again produced oxygen for another short period of time. This could be seen when the propane flame changed colors as oxygen passed through it.

TEST 2. A generator was placed with the oxygen outlet down in a propane fire for 15 minutes. After approximately 5 minutes of exposure to the fire, the generator started producing oxygen from the firing end. The generator produced oxygen for approximately 8 minutes.

TEST 3. A generator packaged in polyurethane foam and a cardboard tube was activated by pulling the firing pin. This is a standard method for shipping individual generators. The generator gave off oxygen almost immediately. After 7 to 8 minutes, smoke started coming out of the top of the package. One to 2 minutes later the package ignited and completely burned in about 5 minutes. See figures 1 and 2.

TEST 4. Three thermocouples were placed along side the generator and held in place with safety wire. The generator was then activated by pulling the firing pin. The temperature at the firing end increased initially, followed by the middle and the outlet end as the reaction progressed. A high temperature of 305°F was recorded at the firing end. After running this test, it was found that the thermocouples had come loose from the side of the generator and may have compromised the temperature readings. See figure 3.

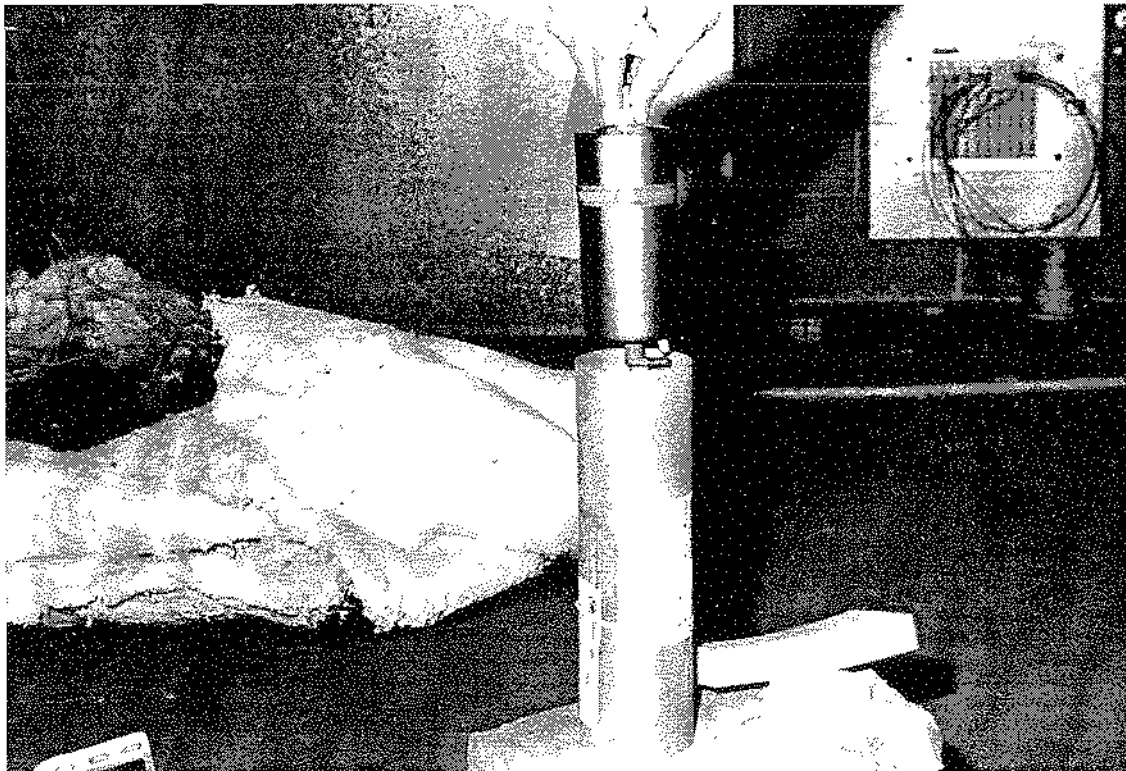

FIGURE 1. GENERATOR BEING PLACED IN A CARDBOARD CONTAINER

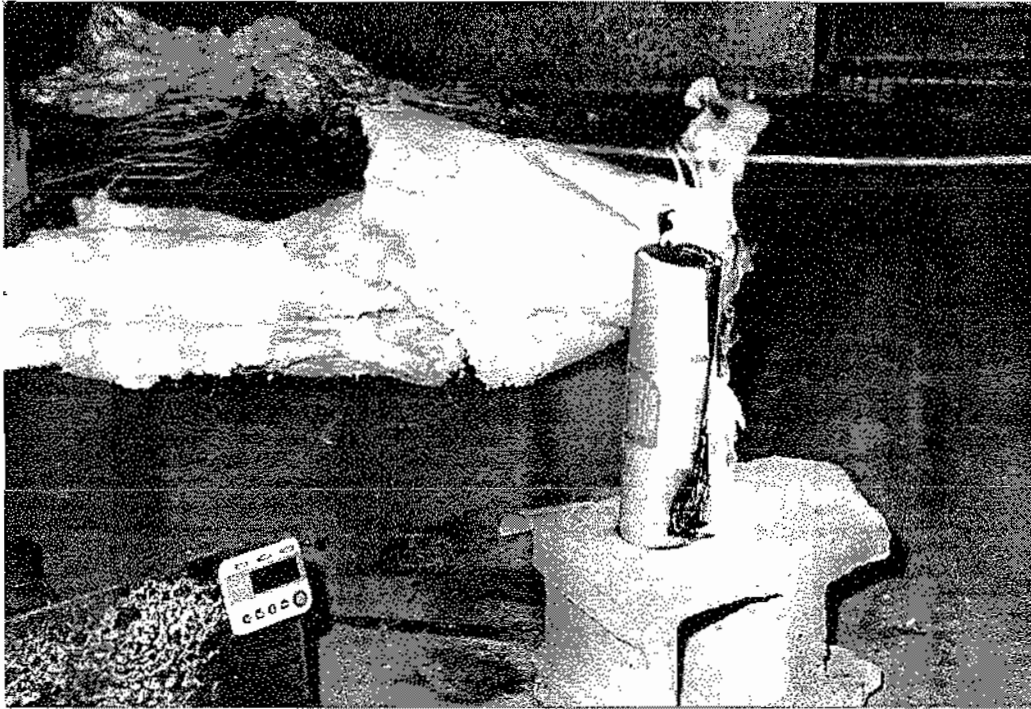

FIGURE 2. GENERATOR PACKAGING IGNITED AFTER THE GENERATOR WAS ACTIVATED

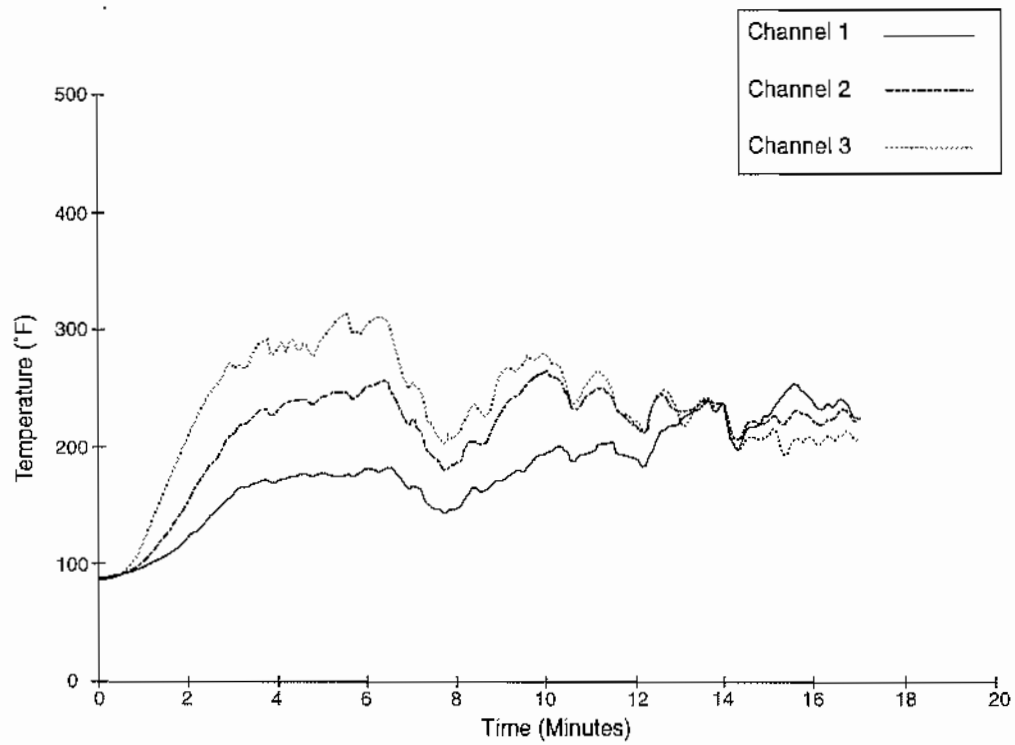

FIGURE 3. TEST RESULTS AFTER THREE THERMOCOUPLES WERE SAFETY WIRED TO THE SIDE OF A GENERATOR

TEST 5. A generator was activated with the firing pin and then immersed in water to help cool the surface of the generator. This is a common practice followed by many airlines for emptying generators that have exceeded their shelf life. After a complete discharge, there was no discoloration of the indicator stripe on the generator. In most cases, without the color change there is no way to tell if the generator has been activated.

TEST 6. Three thermocouples were securely attached to the side of the generator with screws. The high temperature was recorded in the middle of the generator at approximately 330°F. See figure 4.

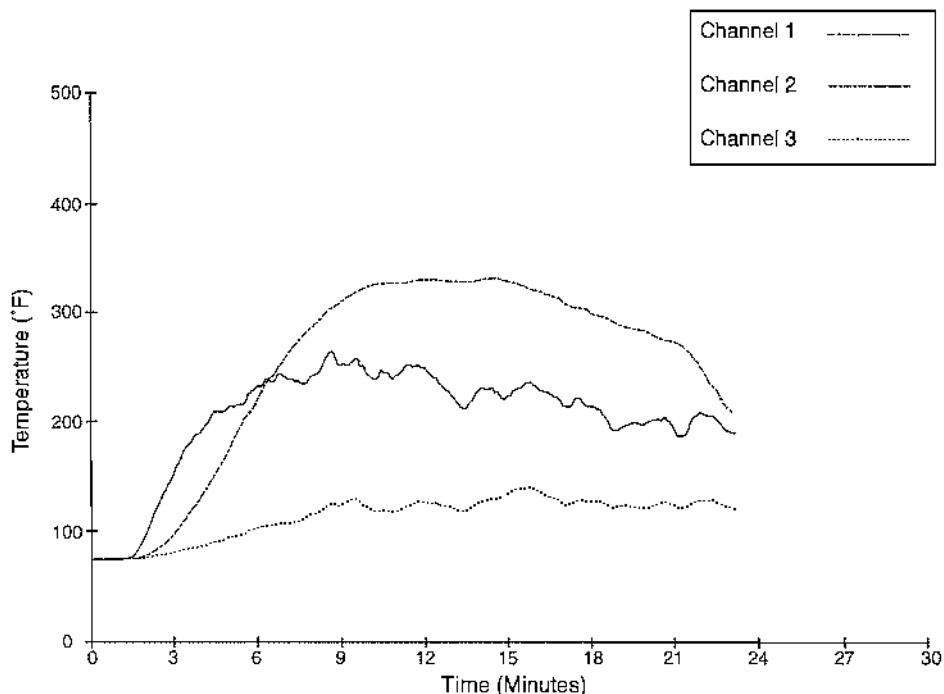

FIGURE 4. TEST RESULTS AFTER THREE THERMOCOUPLES WERE HELD AGAINST THE SURFACE OF A SCOTT 801386-05 GENERATOR WITH SCREWS

TEST 7. A Puritan-Bennett 117003-14 generator was activated by pulling the firing pin and placed in polyurethane foam and a cardboard tube. The package ignited after approximately 5 minutes and completely burned in about 8 minutes after activation of the firing pin.

TEST 8. Seven Puritan-Bennett 117003-14 generators were placed together and tightly secured with safety wire. The group was wrapped in Koawool, a ceramic insulation blanket. The generator in the middle was activated. The heat from that generator was not sufficient to ignite any of the other generators. This demonstrated that without the presence of combustible materials, the activation of one generator will not activate another when properly installed in the aircraft or when shipped correctly.

TEST 9. A Puritan-Bennett 117003-14 generator was activated and packaged similar to test seven. The package ignited in approximately 5 minutes and was completely burned 2 minutes

later, a total of seven minutes. The bottom of the generator was completely consumed by the oxygen-fed fire.

TEST 10. The oxygen outlet on a Scott 803000-03 generator was tapped with screw threads and a screw inserted, plugging the outlet. The pressure relief valve was plugged with a Swagelock fitting. The generator was set off with the firing pin. Within 1 minute both ends of the generator popped out but did not appear to separate. After sitting approximately eighteen hours, there was no pressure in the cylinder. Upon closer examination, the metal had separated around the firing pin. It does not appear that plugging the outlet and pressure relief valve will cause the generator to burst. See figure 5.

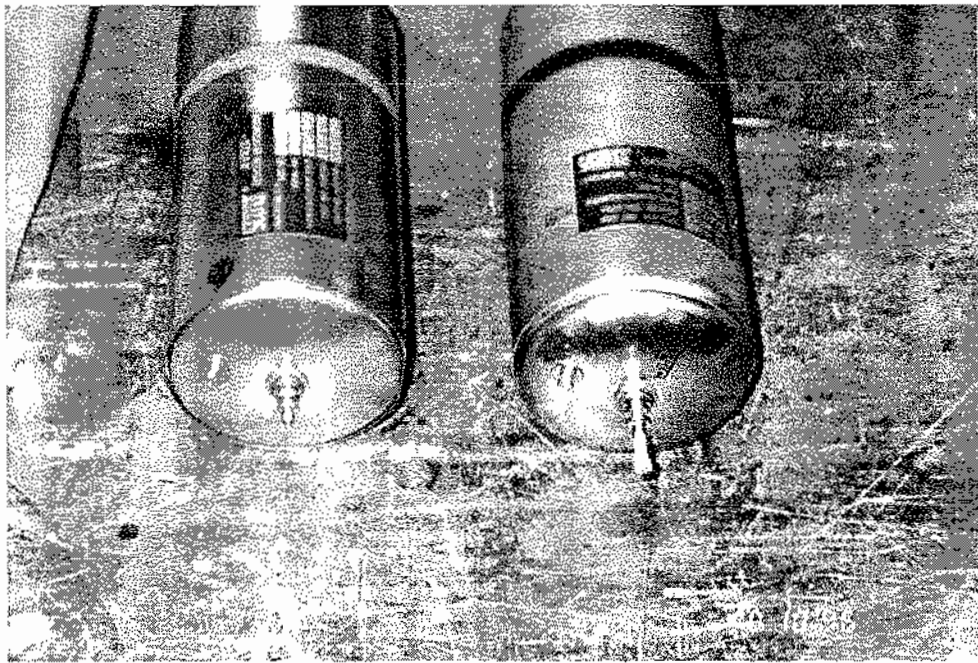

FIGURE 5. GENERATORS OVERPRESSURIZED AFTER PLUGGING THE OUTLETS AND ACTIVATED

TEST 11. Eleven generators were placed in a cardboard box. A wire was attached to the firing pin on a generator at the bottom of the box and then threaded through the box to the outside so that the generator could be activated. Bubble plastic was placed on top of the generators and the box was sealed all around with masking tape. The firing pin was pulled. Only the generator that was activated built up enough heat to scorch the inside of the box. None of the other generators were activated.

TEST 12. A box was packed with 11 generators with a configuration identical to test 11. A wire was attached to the firing pin on a generator at the top of the box next to the bubble pack. The firing pin was pulled. The heat from that generator ignited the packaging and the other generators were activated. The packaging was completely burned. Six of the generators melted together.

TEST 13. A box was packed with 11 generators with a configuration identical to test 11. A wire was attached to the firing pin on a generator at the top of the box, next to the bubble plastic. The box was placed upside down. A small fire occurred at both ends of the box. The fire burned out after approximately 2 minutes. No other generators were activated by the heat from the activated generator.

TEST 14. Eleven generators were packed in a box identical to test 11. A wire was attached to the firing pin on a generator at the top of the box, next to the bubble pack. The box was placed on its side and the firing pin pulled. The box ignited and all 11 generators were activated. Most of the generators' stainless steel shells were melted through. See figure 6.



FIGURE 6. MELTED GENERATORS

TEST 15. Eleven generators were packed in a box identical to test 11. The wire was attached to a generator at the top of the box next to the bubble plastic. The temperature of the torchlike flame was measured with an optical pyrometer and found to be 2700°F. See figure 7. Nine of the generators were melted together. This test had to be repeated twice to get the box to ignite. Humid conditions during the test may have contributed to the failure of the boxes to burn initially.

TEST 16. One Scott 801386-83 generator was placed on a thermocouple fixture that was fabricated to firmly hold the generator to the thermocouple tips for a more accurate temperature reading. The generator was then activated by pulling the firing pin. The temperature reached 250°F after 7 to 8 minutes.

TEST 17. A Scott 801386-82 two-person generator was placed on the thermocouple fixture and activated by pulling the firing pin. The temperature reached approximately 290°F.



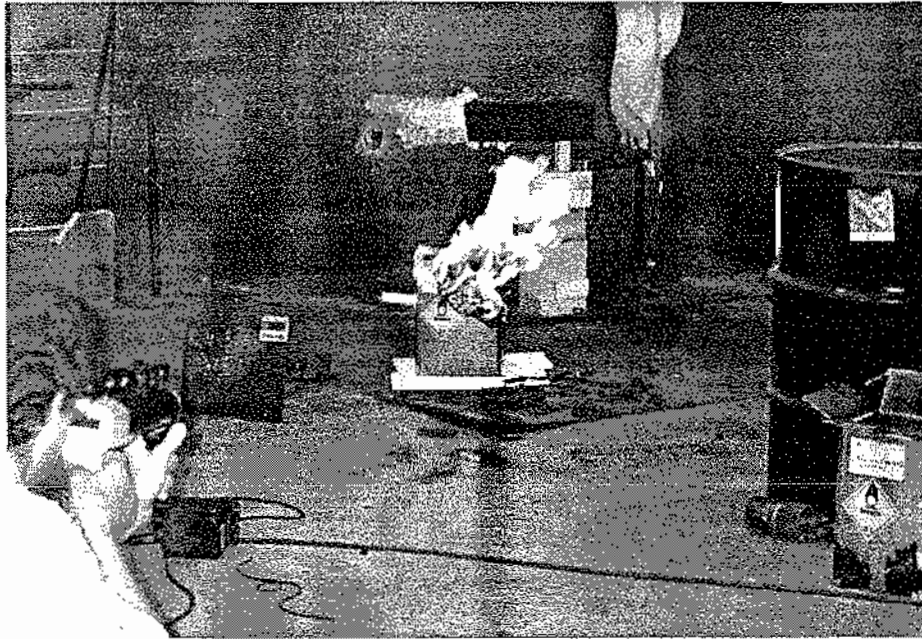

FIGURE 7. TEMPERATURE OF FLAMES BEING MEASURED WITH A PYROMETER

TEST 18. A Scott 801386-06 three-person generator was placed on the thermocouple fixture and activated by pulling the firing pin. The temperature reached approximately 250°F. Tests 16-19 seem to indicate that the generator size does not affect how high the surface temperature will rise.

TEST 19. A Puritan-Bennett 117003-14 four-person generator was placed on the thermocouple fixture and activated with the firing pin. The temperature reached approximately 250°F.

TEST 20. Six generators were packaged in cardboard tubes with polyurethane foam. The six tubes were packed in a cardboard box with bubble plastic. A thermocouple was placed in the box to record the rise in temperature indicating that the generator had been activated. After activating one of the generators, a small fire occurred. After 13 minutes, heat from the fire activated another generator. All six generators discharged. See figure 8.

TEST 21. In order to more accurately read the surface temperature, a thermocouple was spot welded to the side of a Scott 801386-06 three-person generator. The surface temperature peaked at 410°F 9 minutes after activating the generator. This is much closer to but still less than the manufacturer's maximum allowable 500°F surface temperature. There were no visible signs of smoke, sparking, or physical distortion. See figures 9 and 10.

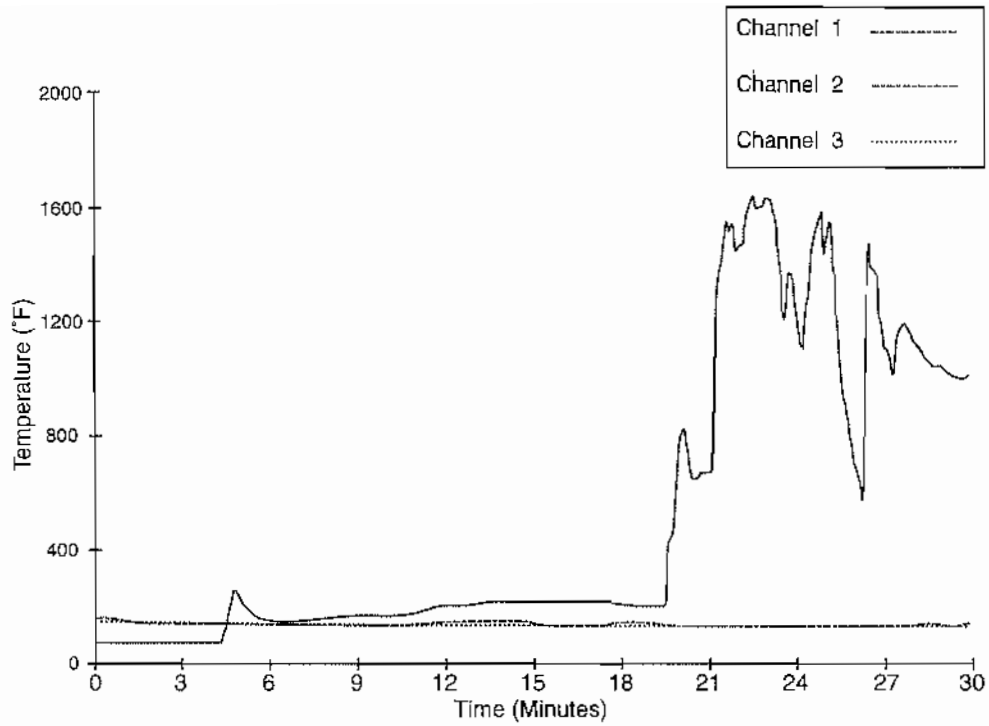

FIGURE 8. TEST RESULTS AFTER SIX GENERATORS WERE PACKED IN TUBES AND THE TUBES PACKED IN A BOX AND ACTIVATED

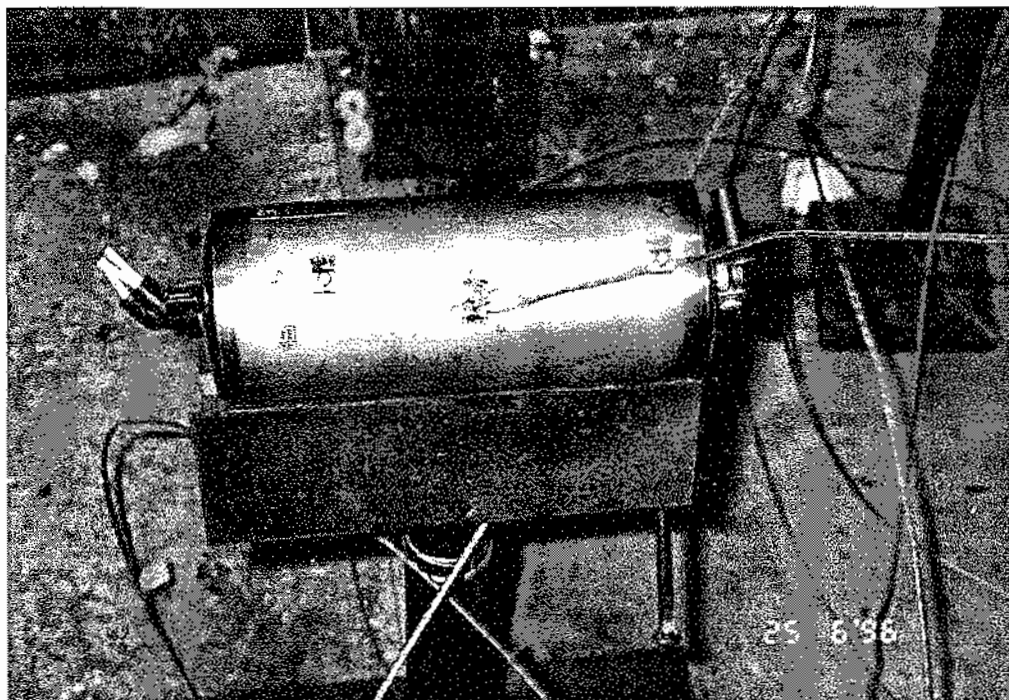

FIGURE 9. THERMOCOUPLE SPOT WELDED TO THE SIDE OF A THREE-PERSON GENERATOR

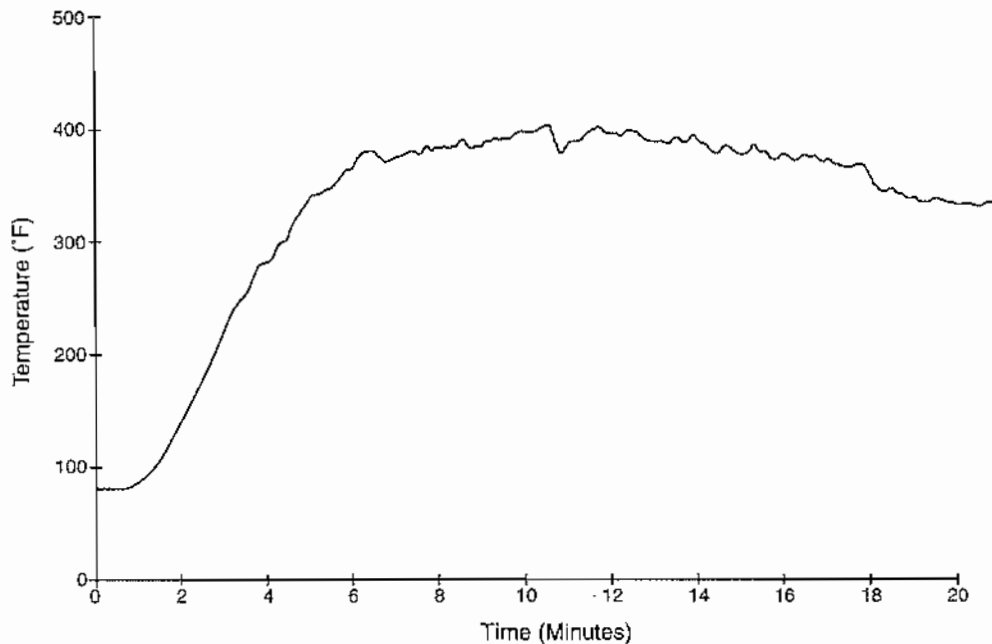

FIGURE 10. RESULTS OF THE SPOT-WELDED GENERATOR TEST

TEST 22. Three generators were placed in a tin can used for shipment of hazardous or dangerous chemicals. Normally the can is packed with vermiculite, a noncombustible material, used to cushion shipping material. However, for this test no vermiculite was used. Only one of the three generators was activated. The lid was placed on the can and taped in place. A thermocouple was placed inside the container to indicate a successful ignition and record the temperature inside the can. There was no sign of smoke or fire; this demonstrates that without combustible material the generators would be relatively safe for shipment. See figure 11.

TEST 23. Six generators were packed in a cardboard box with bubble plastic on top. A wire was threaded from the outside, through the box, to a firing pin on the generator in the middle. A thermocouple was placed in the box to indicate successful ignition and to measure box temperature. The box was placed on its side with the activated generator in the bottom center. Smoke was noticed 3 to 4 minutes after the generator was activated. Fire developed shortly after, completely consuming the box. The other five generators were activated by the fire. The temperature in the box reached 1900°F. See figure 12.

TEST 24. Two generators, the Puritan-Bennett 117003-13 and the Scott 801386-83, were completely surrounded with vermiculite and packed in a cardboard box. The Puritan-Bennett generator was placed on the bottom and activated. The Scott generator was not activated. The box was closed after activation, and the test ran for 20 minutes. Although the box got warm, no flames or smoke were observed. After unpacking and inspecting the box, generators, and vermiculite, no heat damage was found other than the color change of the activation band on the Puritan-Bennett generator. See figures 13 and 14.

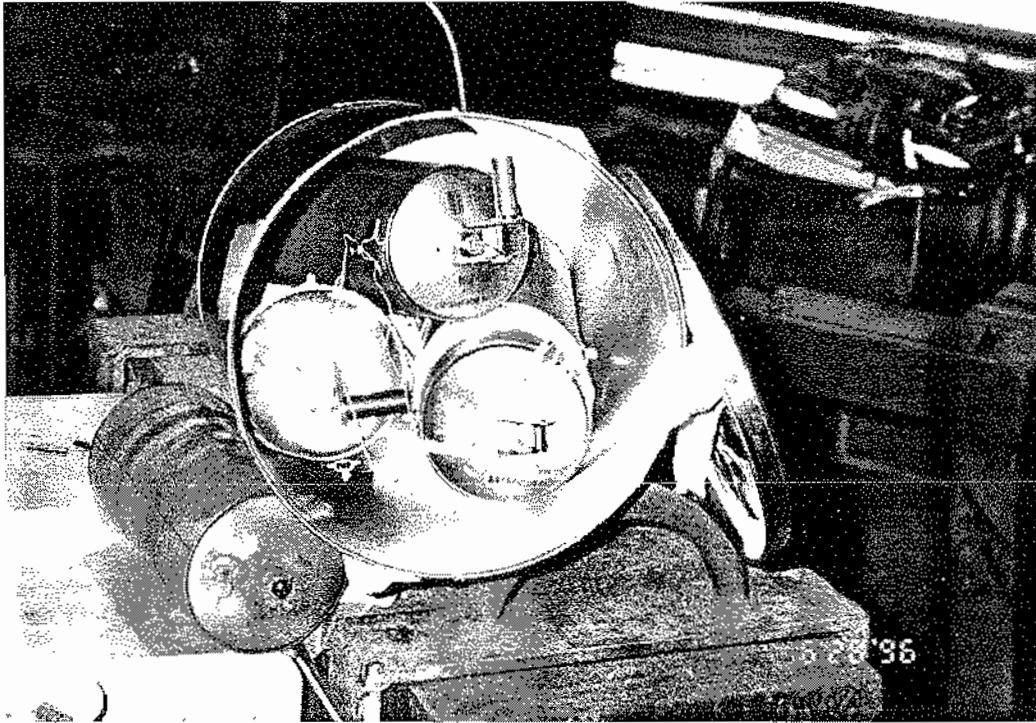

FIGURE 11. THREE GENERATORS PLACED IN A TIN CAN

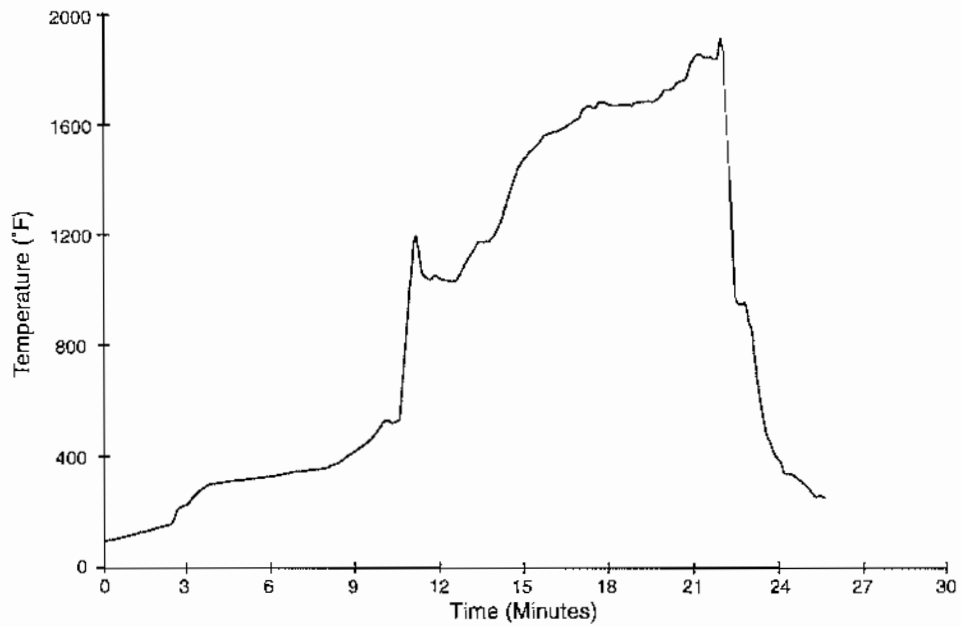

FIGURE 12. TEST RESULTS AFTER SIX GENERATORS WERE PACKED IN TUBES AND PACKED IN A BOX AND THE BOX PLACED ON ITS SIDE



FIGURE 13. GENERATOR PACKED IN NONCOMBUSTIBLE MATERIAL

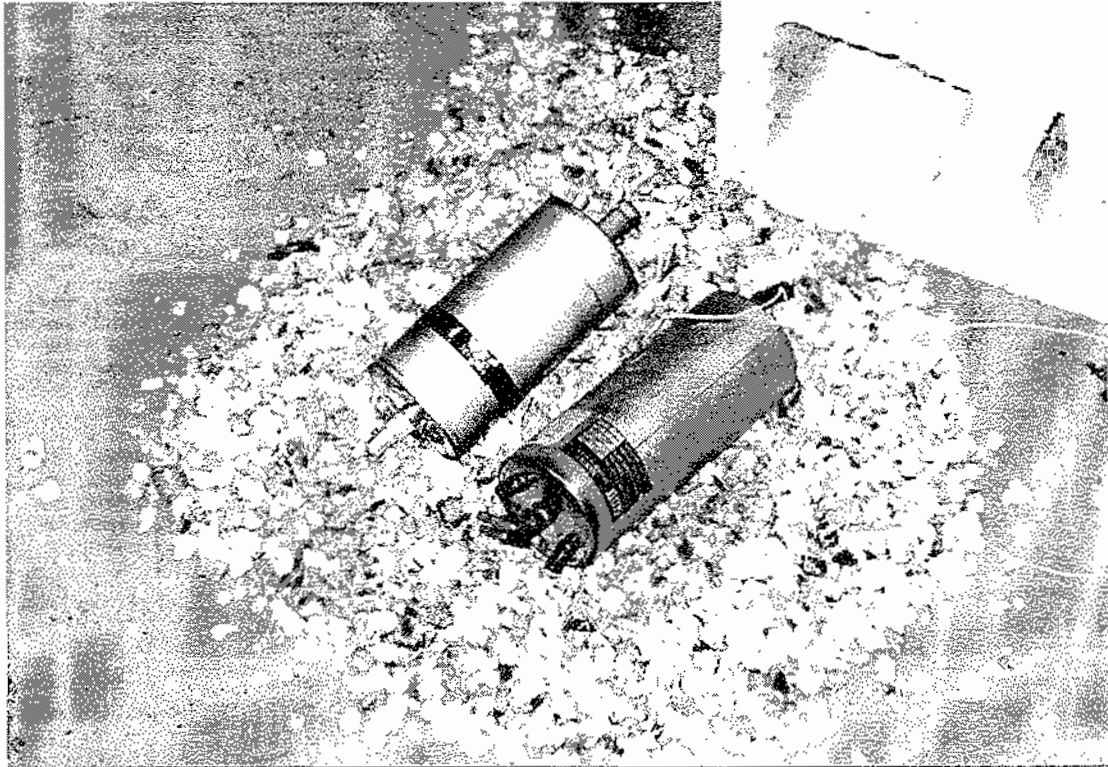

FIGURE 14. GENERATORS AFTER ACTIVATION AND REMOVED FROM BOX

Test 25. Eight Scott 801462-06 electrically activated generators were placed in a cardboard box with bubble plastic on top. The generator on top, next to the bubble plastic, was activated with a battery. The temperature inside the box peaked at 275°F. These generators, from an L-1011, come with a metal mesh heat shield that prevents combustible material from coming into direct contact with the hottest part of the generator. Heat from the generator melted the bubble plastic and a small amount of smoke was seen. The melted bubble plastic did not drip past the heat shield mesh. See figure 15.

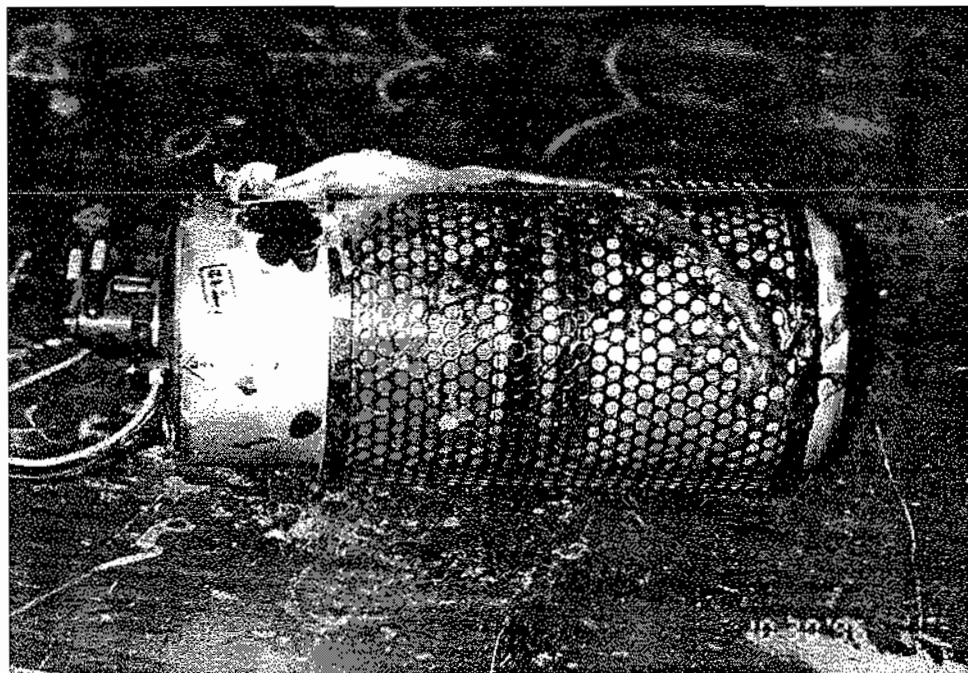

FIGURE 15. ELECTRICALLY ACTIVATED GENERATOR WITH HEAT SHIELD AND MELTED BUBBLE PLASTIC

Test 26. Eight Scott 801462-16 electrically activated generators were placed in a cardboard box with bubble plastic and polyurethane foam packaging on top. The generator on top, next to the foam and bubble plastic, was activated with a battery. The polyurethane foam melted and dripped through the heat shield mesh. Heat from the generator caused a fire after approximately 6 minutes. The temperature recorded inside the box reached 1075°F approximately 17 minutes after activation. The fire did not ignite the remaining generators.

Test 27. The sodium chlorate core was removed from a generator before activation. Heat from a butane torch was applied to the body of the core to determine if a fire could cause a self-sustaining reaction. The core gave off oxygen as long as heat was applied, but the reaction stopped as soon as the heat was removed. Heat was then applied to the igniter end of the core. This end ignited immediately with large quantities of white fire and smoke. A self-sustaining reaction occurred. Due to the removal of the core from the insulated stainless steel container, the fire self extinguished after eight minutes. The core expanded into a porous, rock-like substance after the reaction. Figure 16 shows a disassembled generator. Figure 17 shows a cutaway drawing of an electrically actuated generator.

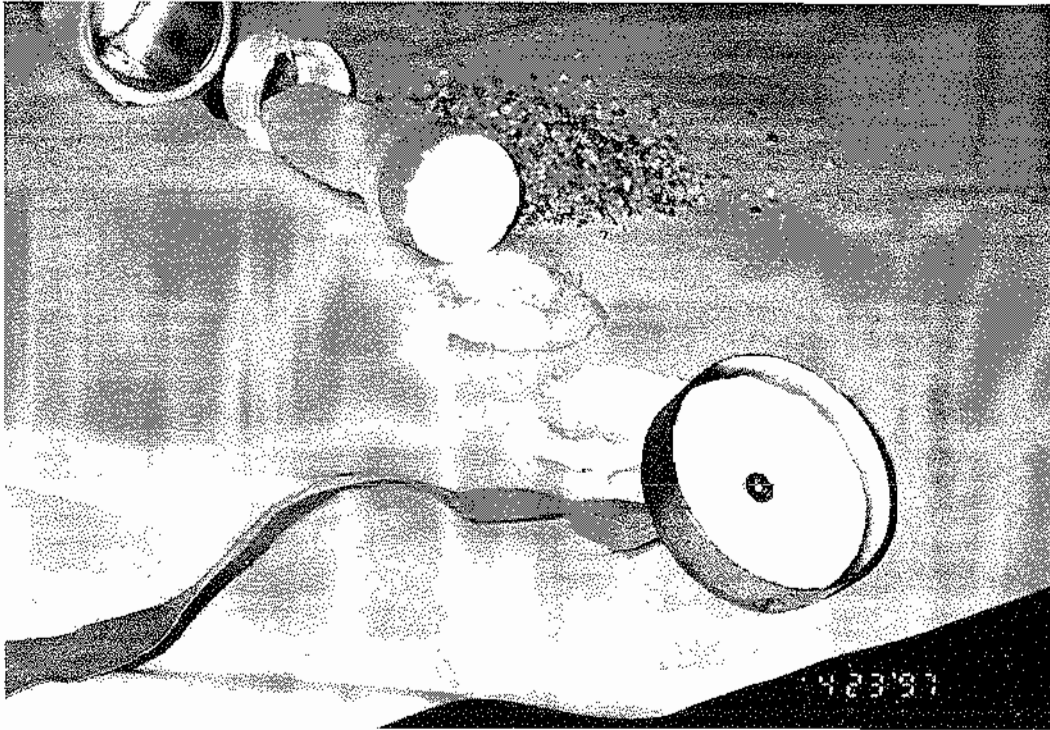
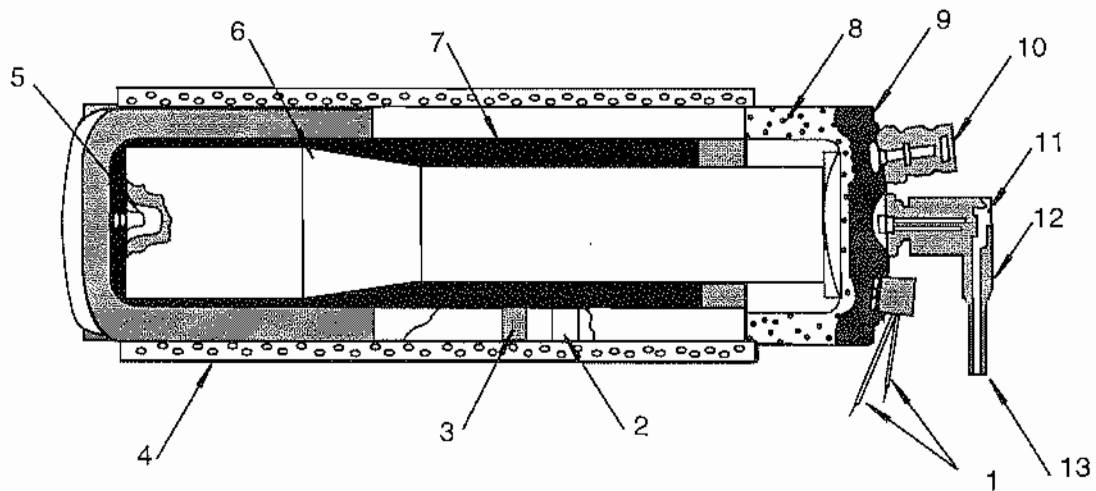

FIGURE 16. DISASSEMBLED GENERATOR



- |                            |  |
|----------------------------|--|
| 1. Electrical leads        | 7. Core support                          |
| 2. White stripe            | *8. Hopcalite                            |
| 3. Black comparison stripe | 9. Filter pad                            |
| 4. Shield                  | 10. Relief valve assembly (50 to 75 psi) |
| 5. Igniter assembly        | 11. Outlet port                          |
| 6. Chemical core           | 12. Manifold assembly                    |
|                            | 13. Manifold assembly outlet             |

\* A granular mixture of the oxides of copper, cobalt, manganese and silver used in gas masks to convert carbon monoxide to dioxide.

FIGURE 17. CUTAWAY VIEW OF ELECTRICALLY ACTIVATED GENERATOR

## CONCLUDING REMARKS

The activation of an aircraft oxygen generator canister produced surface temperatures above 400°F. Tests conducted in this report demonstrate that a generator activated in a confined space may ignite adjacent combustible material due to the hot surface and elevated oxygen concentration. This was shown with cylindrical cardboard shipping containers with urethane foam pads and with cardboard boxes with bubble plastic shipping material. In addition, the initial fire involving burning combustible material will cause additional generators to activate, creating an intense fire associated with burning in an oxygen-enriched environment and reach temperatures above 2700°F. Means of shipping or storing generators to prevent a fire in the event that a generator is accidentally activated were demonstrated.