

Development of the Next Generation Fire Test Burner for Powerplant Fire Testing Applications

Presented to: IASFPWG, London, UK

By: Robert Ochs

Date: Tuesday, May 18, 2010



Federal Aviation
Administration



FAA Regulatory Information

- **Numerous FAR's mandate fire protection in aircraft powerplant fire zones**
 - Parts 23, 25, 27, 29, 33...
 - FAR Part 1 Section 1.1 – Definitions and Abbreviations
 - Fireproof--
 - (1) With respect to materials and parts used to confine fire in a designated fire zone, means the capacity to withstand at least as well as steel in dimensions appropriate for the purpose for which they are used, the heat produced when there is a severe fire of extended duration in that zone;
 - (2) With respect to other materials and parts, means the capacity to withstand the heat associated with fire at least as well as steel in dimensions appropriate for the purpose for which they are used.
 - Fire resistant--
 - (1) With respect to sheet or structural members means the capacity to withstand the heat associated with fire at least as well as aluminum alloy in dimensions appropriate for the purpose for which they are used; and
 - (2) With respect to fluid-carrying lines, fluid system parts, wiring, air ducts, fittings, and powerplant controls, means the capacity to perform the intended functions under the heat and other conditions likely to occur when there is a fire at the place concerned.
 - No definition of test method, apparatus, or criteria
 - Advisory material has been used to define these test parameters

Research - Current FAA Documentation

- **Advisory Circulars and FAA Reports:**
 - Power Plant Engineering Report No. 3A, Standard Fire Test Apparatus and Procedure (For Flexible Hose Assemblies), Revised March 1978
 - Acceptable fire test burners listed in Appendix III:
 - Lennox OB-32 (not available)
 - Carlin 200 CRD (not available)
 - Stewart-Warner HPR 250 (not available)
 - Stewart-Warner FR-600 (not available)
 - AC 20-135, Powerplant Installation and Propulsion System Component Fire Protection Test Methods, Standards, and Criteria, 2/6/90
 - Acceptable fire test burners listed in sec. 6c:
 - Those listed in Appendix III of Powerplant Report 3A
 - SAE 401 Burner adjusted to 9.3 BTU/ft²s (propane fueled burner)
 - Propane and oxy-acetylene torch-standard and diverging nozzles
 - FAA Aircraft Materials Fire Test Handbook (4/2000)
 - Chapter 11 specifies the oil burners listed above, plus
 - Park DPL 3400 (not available)
 - Chapter 12 specifies the oil burners above, including the Park DPL 3400
 - Chapter 12 Supplement, section 12.3.1 states:
 - » SAE AS401B Propane Burner is also acceptable provided the temperature profile and heat flux density conform to the specified requirements
 - AC 33.17-1A, Engine Fire Protection, 8/3/09
 - References Powerplant Report 3A and AC 20-135 for acceptable burners

Current Status

- **All of the specified oil burners are no longer commercially available**
- **Industry is left with the propane burner, which can be obtained and is typically preferred due to its consistency and ease of use**
 - Propane and jet fuel flames, despite having similar measured temperatures and heat flux, are fundamentally different
 - Propane will provide a less severe flame than a jet fuel flame, due to the transparency of the propane flame vs. the opacity of the jet fuel flame
 - As test components approach the flame temperature, they begin to re-radiate due to the high surface temperature
 - Heat is lost readily from the hot surface through the transparent propane flame
 - Heat is not lost through the opaque jet fuel flame
 - Intent of regulations is to provide protection against an *engine* fire, which is a jet fuel flame, not a propane flame
- **FAA Tech Center Fire Safety Team has been tasked by Transport Airplane Directorate to develop burner performance standards for the next-generation fire test burner for powerplant fire testing**



What is a NexGen Burner?

- The next generation (NexGen) burner was designed by the FAA Technical Center to be used as an equivalent burner to the Park DPL 3400 which is no longer in production
- The NexGen burner relies on the same operating principles as the Park DPL 3400, which was designed for home heating purposes
 - Oil burner fuel nozzle, 80° hollow cone, 6.0 gph
 - Average flame temperature ~ 1900°F
 - Average flame heat flux ~ 15 BTU/ft²s
- The NexGen burner uses compressed air and fuel to supply the burner, whereas the Park DPL 3400 uses an electric motor to spin a blower fan and mechanical fuel pump
 - Air Flow Metering:
 - Park uses a butterfly throttle valve
 - NexGen uses a sonic orifice
 - Fuel Pressure
 - Park uses pressure regulator on pump
 - NexGen uses fuel tank head pressure
 - Both air and fuel temperature are restricted to a 20°F range by using an ice bath heat exchanger
- Major advantages of a NexGen burner:
 - Precise metering of inlet parameters
 - Can be constructed in-house with easily obtainable materials
 - Can be easily modified for future upgrades (as a result of FAATC research)

Park DPL 3400



NexGen Burner



NexGen Burner Components

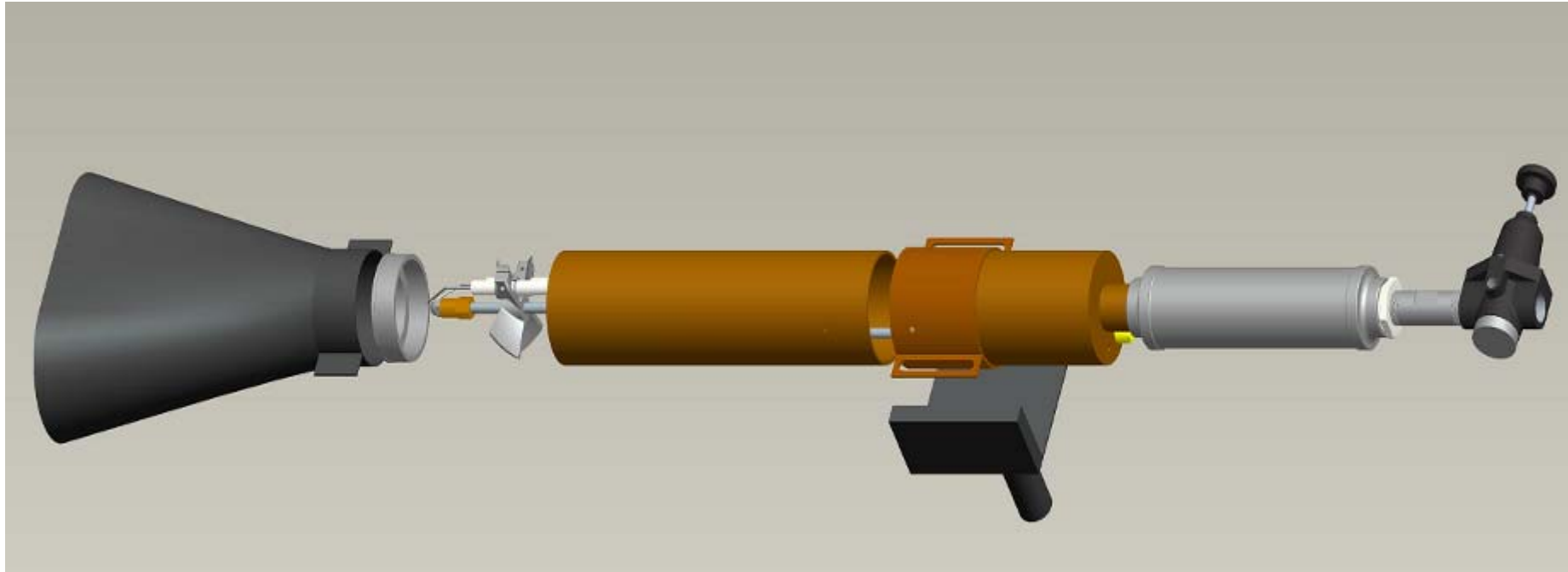

Cradle

NexGen Drawings

- Drawings are available online at

<http://www.fire.tc.faa.gov>

➤ Home

➤ Materials

➤ Thermal/Acoustic Insulation

➤ Burnthrough

➤ NexGen Burner

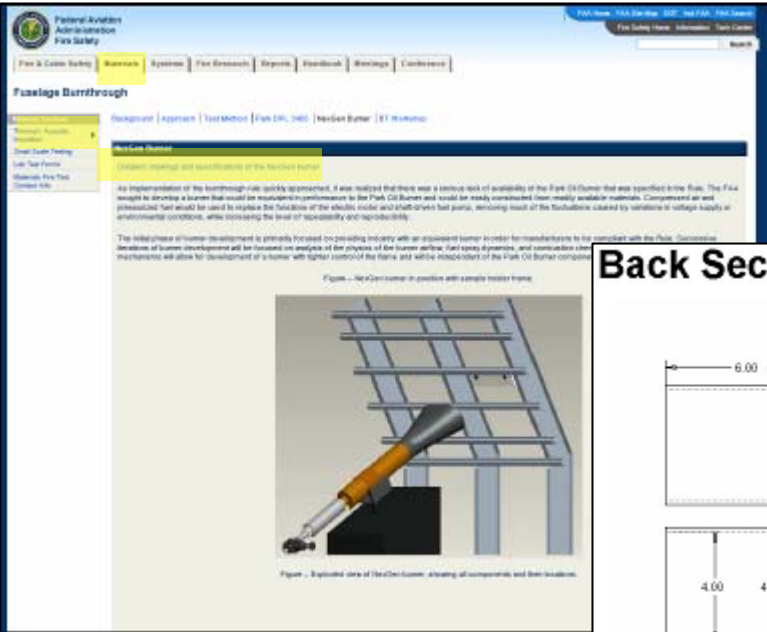

Back Section

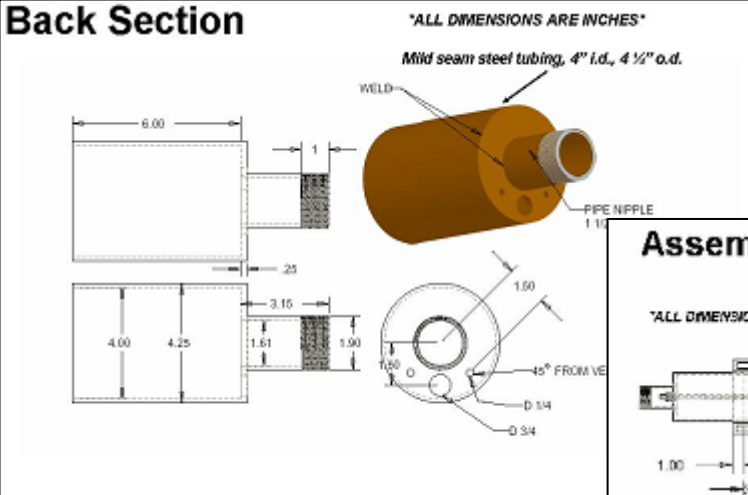

Assembled NexGen Burner Housing

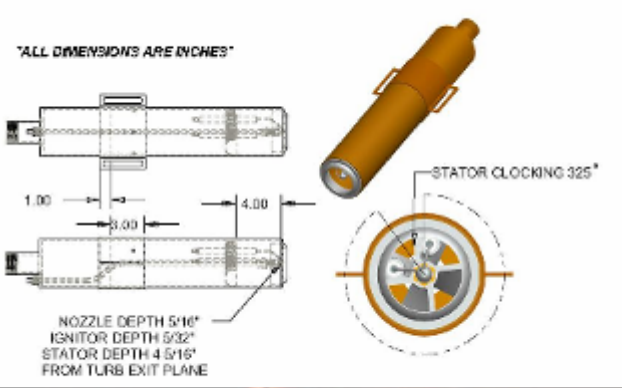

Development of NexGen Fire Test Burner for Powerplant Fire Testing Applications
May 18, 2010

NexGen Burner Calibration

- **For the NexGen burner, the heat flux measurement has been removed from the calibration procedure**
 - Heat flux transducers measure instantaneous heat flux at a very small point in the flame
 - Specifically, Gardon gauges were designed and are intended for measuring intense thermal radiation only
 - Use in an intense, mixed-mode heat transfer environment introduces significant measurement uncertainty
 - Since all inlet parameters and burner dimensions are fixed, no adjustments can be made to achieve a specified heat flux
- **Flame temperature is measured and used to determine proper burner output**
 - 1/8" S.S. sheathed ceramic packed K-type thermocouples
 - 7 TC's, 4" from burner exit plane and 1" above exit cone centerline
 - For burnthrough, acceptable temperature range is 1900°F ±100°F
 - TC readings have been found in the 1700's, which indicates improper function
 - Typically means soot "jackets" form on TC sheath, insulating TC and causing false low temperature readings
 - Can be corrected by "indexing" fuel nozzle to correct spray pattern
- **Ultimate test of similarity between Park DPL 3400 and NexGen was comparative burnthrough testing**
 - Polyacrylonitrile (PAN) fabric material of 2 different densities was chosen due to their typical burnthrough times
 - 16 oz/yd² ~ 4 min. BT
 - 9 oz/yd² ~ 3 min. BT
 - 25.856b pass/fail criteria is 4 min BT resistance
 - A "picture-frame" sample holder was created to hold material
 - Tests were performed on the Park DPL 3400 and several NexGen burners at different labs

Comparative Validation Testing



- NexGen burners were shipped out to participating laboratories in order to determine the repeatability of the test results in various environments
- Very good agreement was found between labs 4 and 6 and the rest of the NexGen's tested at the FAATC
- All labs and burners were found to have less than 5% relative standard deviation, indicating good repeatability
- Labs 4 and 6 were approved by their respective A.C.O.'s to perform certification tests according to the rule

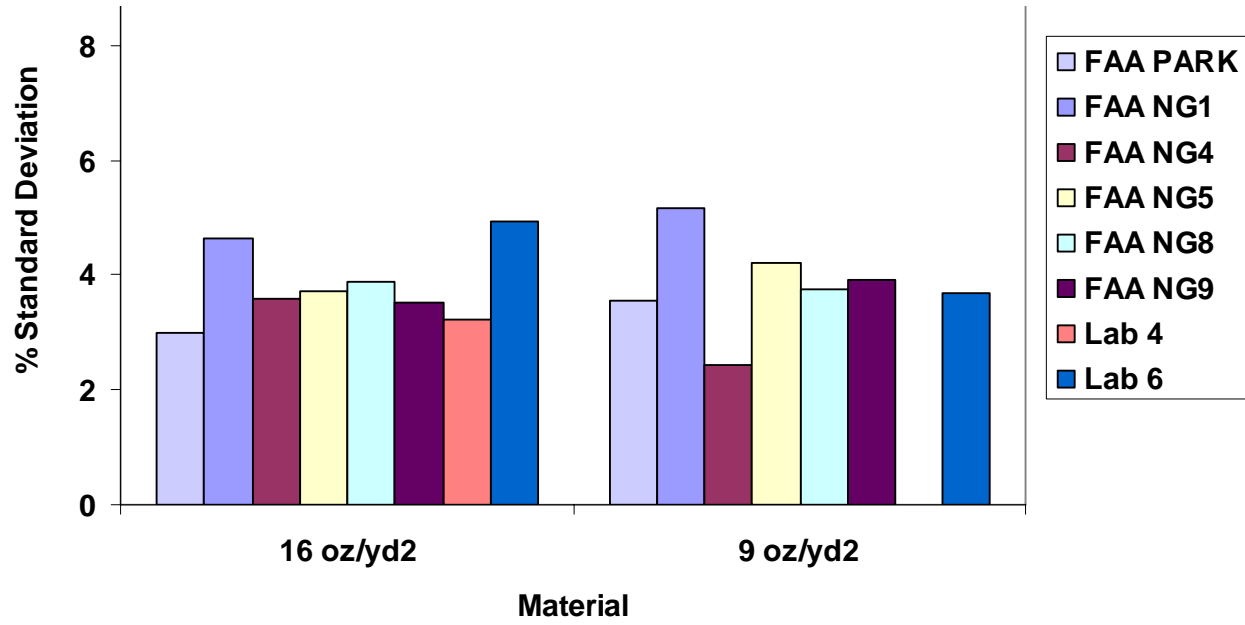
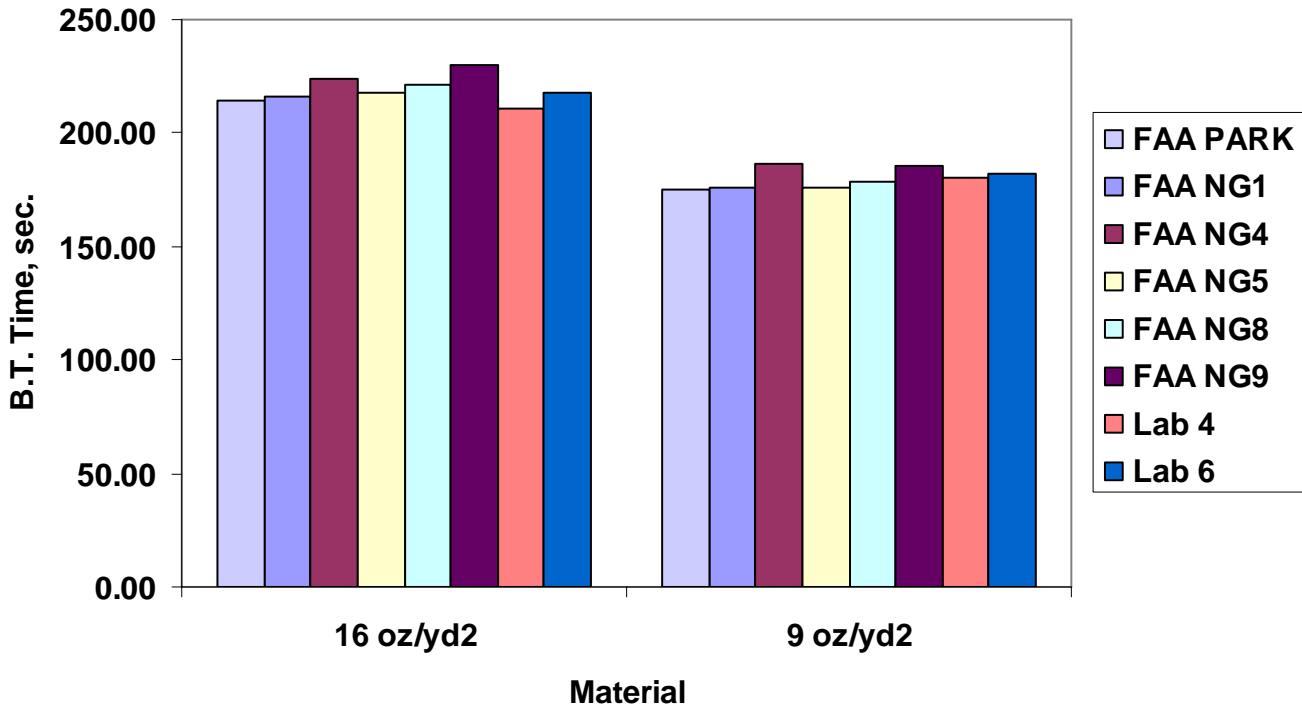

Application of NexGen Burner to Powerplant Fire Testing

- **Slight modifications to be made:**
 - Burners specified in AC 20-135 are based on the 2.0 gph fuel flow rate
 - Same burner for the seat test (25.853) and cargo liner burnthrough (25.855), which is a 2.0 gph fuel flow rate nozzle and lower air flow rate than the burnthrough burner
 - Currently, FAATC is near completion of developing NexGen burner operating parameters for the seat test
 - Configured a NexGen burner to achieve seat test performance similar to a Park DPL 3400 calibrated to standards set in chapter 7 of the Aircraft Materials Fire Test Handbook
 - Fuel flow rate of 2.0 gph \pm 0.1 gph
 - Equivalent to an inlet air flow of 67 \pm 4 cfm
 - Flame temperatures of at least 1800°F on 5 of 7 thermocouples and at least 1750°F on at most 2 thermocouples
 - 30-second average of 7 thermocouples at least 1800°F

Equivalent Air Flow Rate

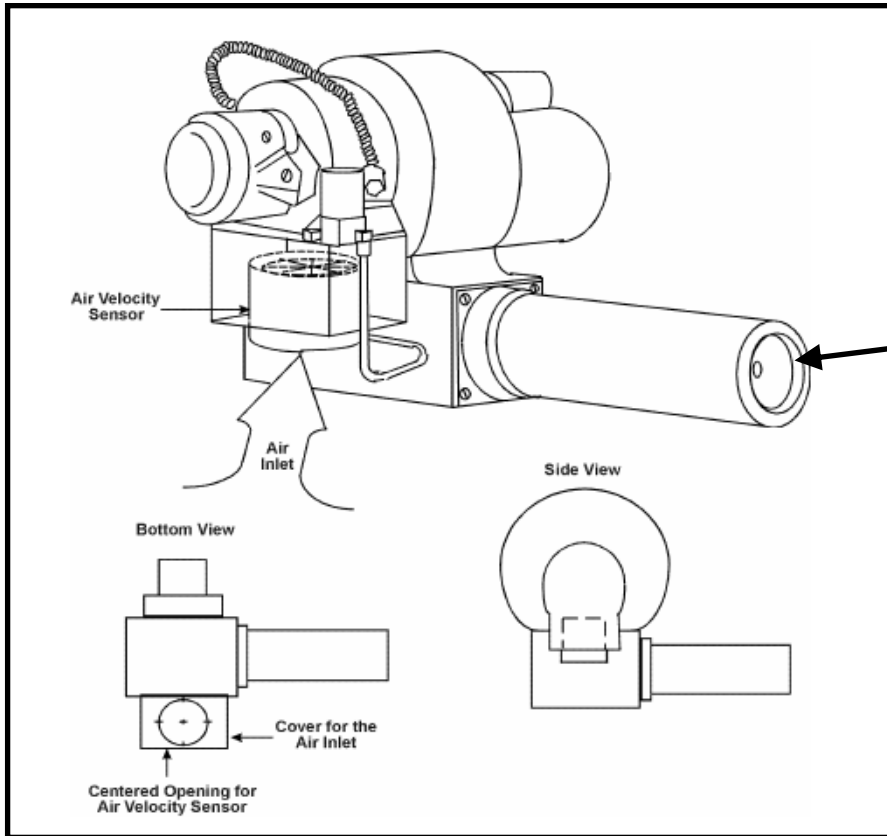

Inlet Air Flow:

67 cfm \approx 1800 fpm in 2.625 in² air flow meter (HH30)

Exit Air Flow \sim 1600 fpm

Resulting Sonic Choke
Inlet Pressure: 47 psig

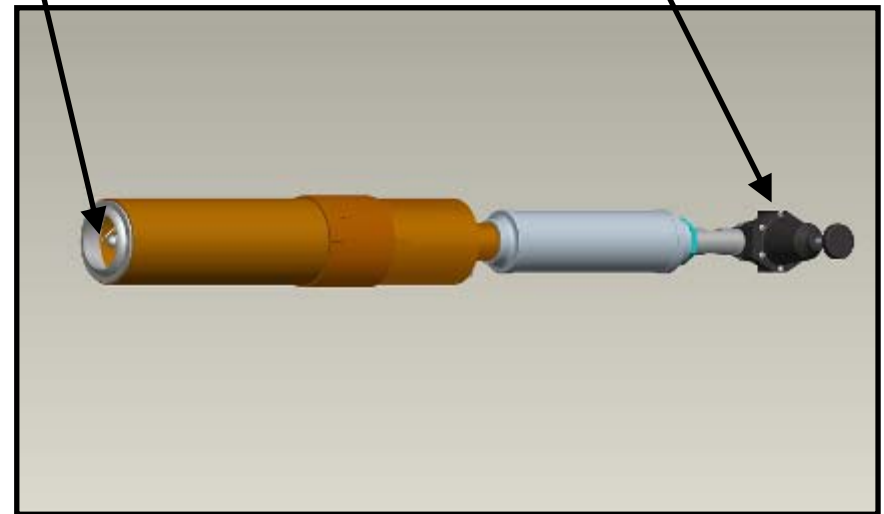



COMPARISON OF NEXGEN BURNER WITH SEAT ROUND ROBIN 2006*

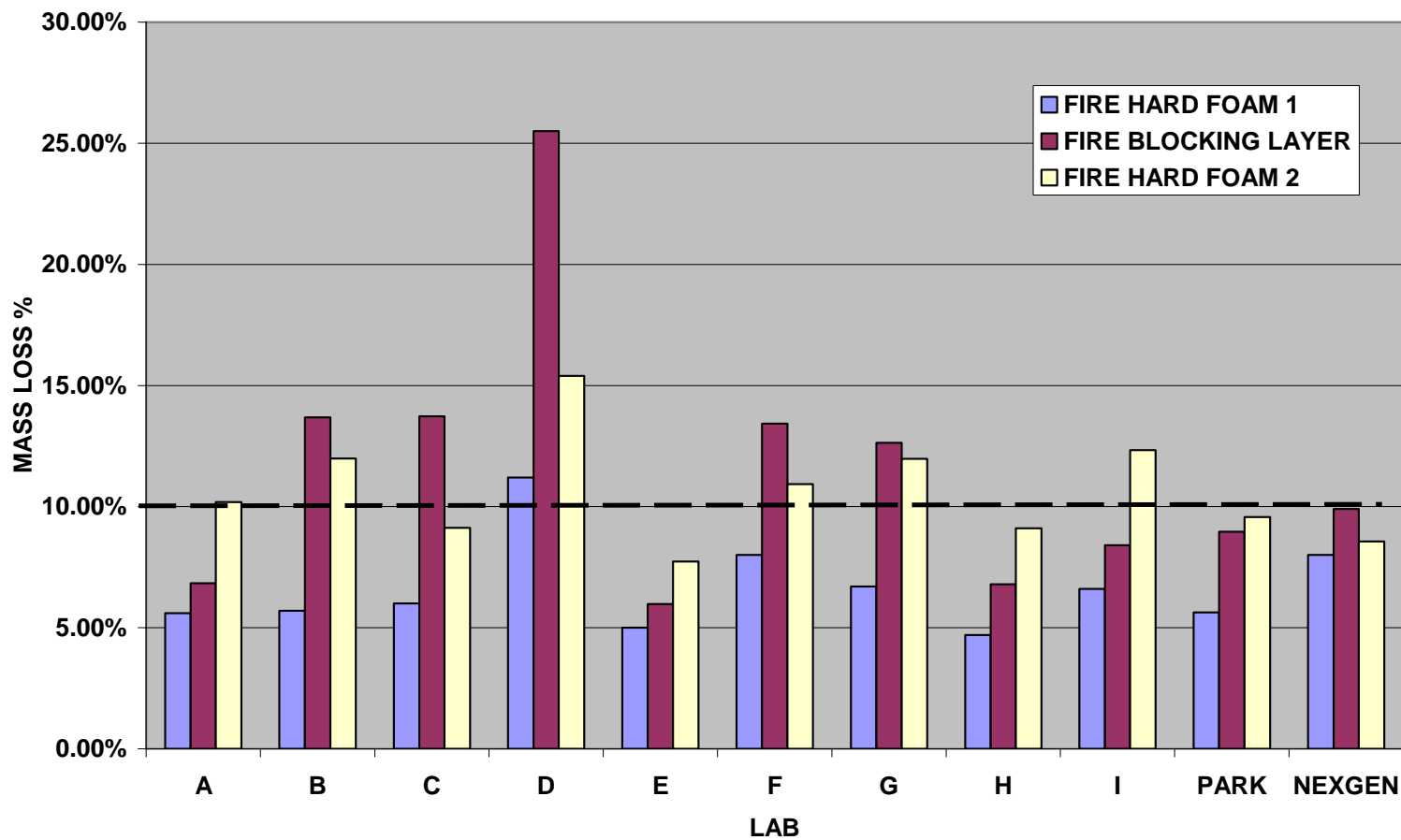

NexGen Burner Development - Summary

- **The NexGen burner has been proven to provide a flame similar to an oil burner calibrated according to**
 - 25.853 seat cushion flammability test
 - 25.856b insulation burnthrough test
- **Comparative testing was used to validate burner performance**
- **Measurement of flame heat flux has been eliminated due to tighter control of burner inlet parameters**

Thermocouple Effects



- **Tests were performed to determine the effect of the thermocouple on the measured flame temperature**
 - 1/16" ss sheathed ceramic packed K type TC
 - Old
 - New
 - 1/8" ss sheathed ceramic packed K type TC
 - New
 - 1/8" ss sheathed ceramic packed K type TC
 - Exposed Junction
 - New

Thermocouple Effects

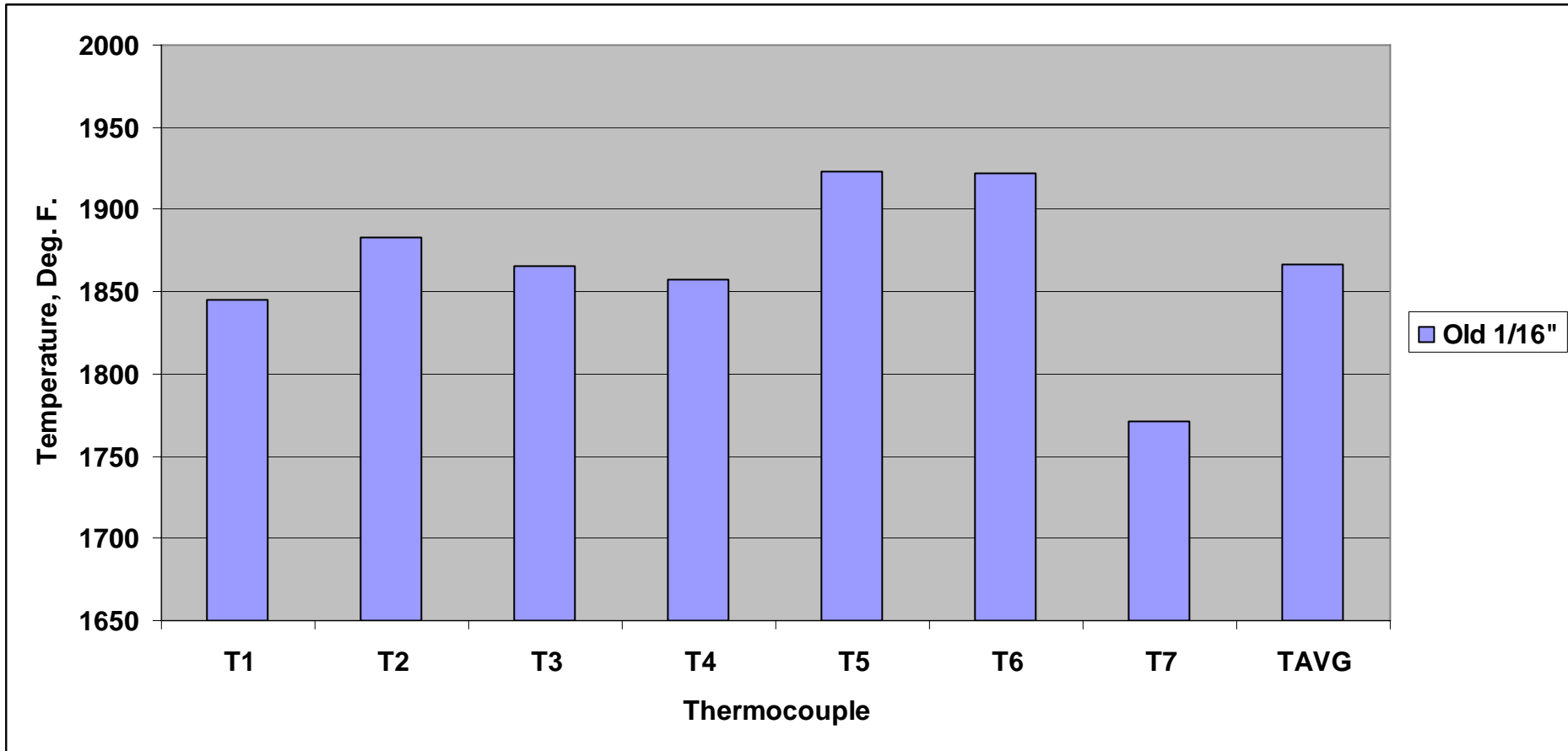

Thermocouple Effects

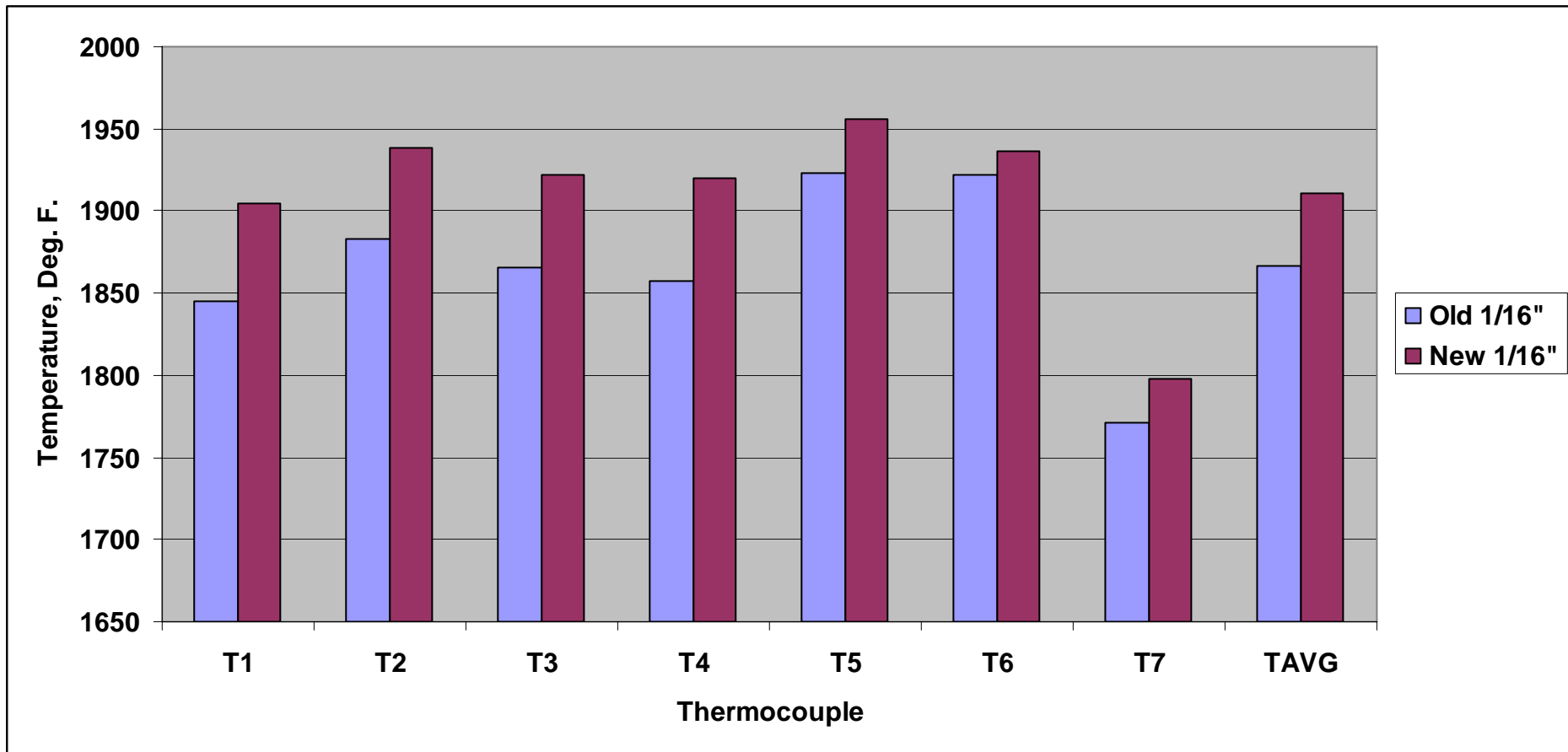

Thermocouple Effects

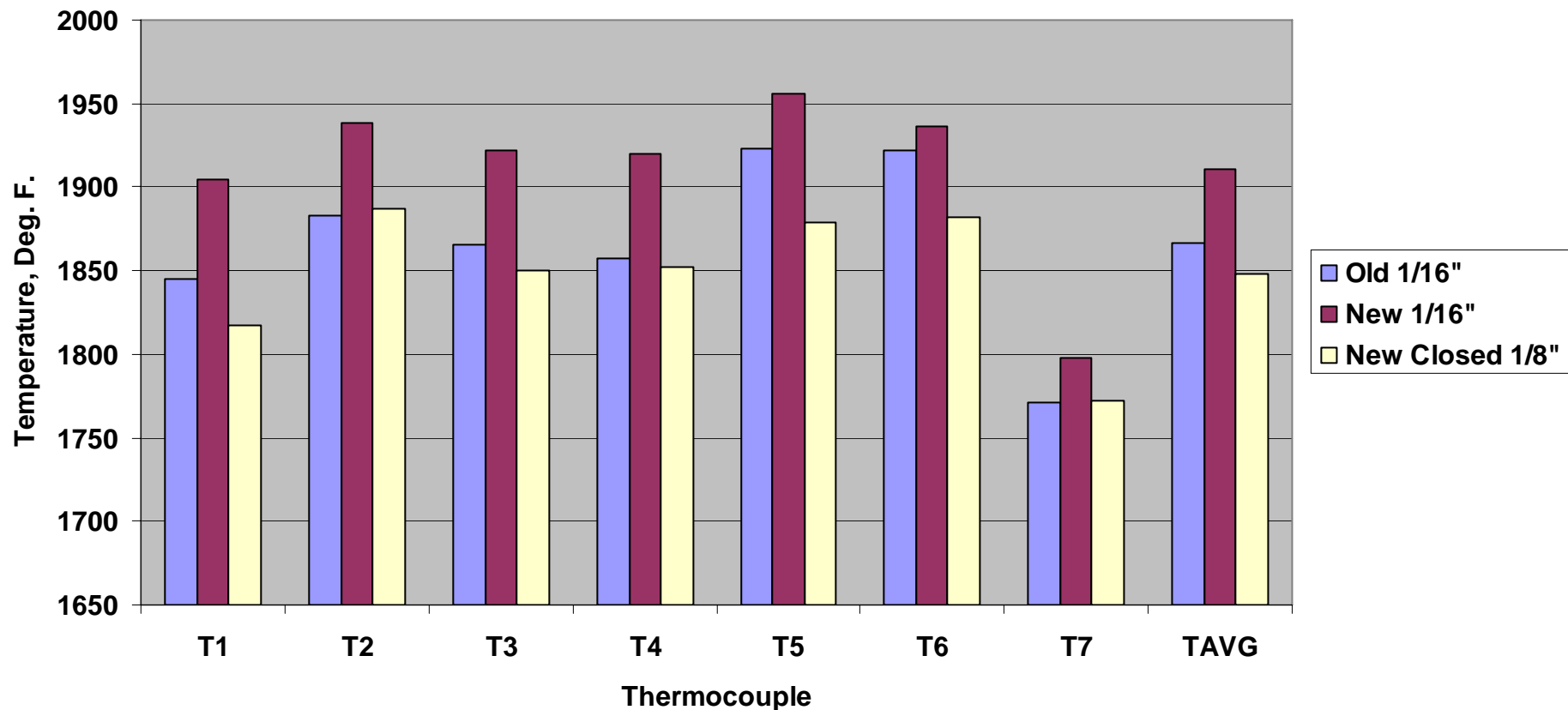

Thermocouple Effects

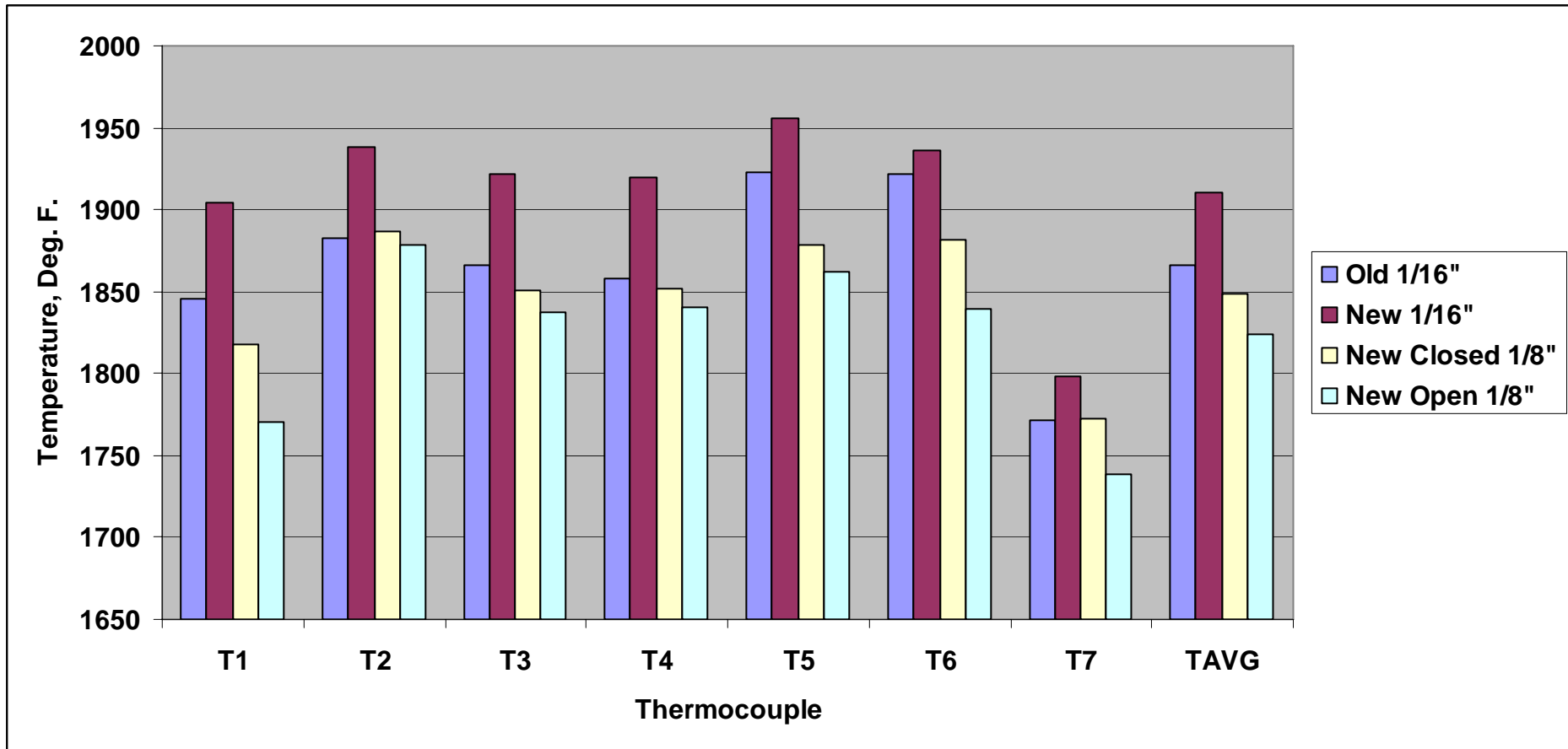

Thermocouple Effects - Summary

- **Thermocouple size, construction, and age all have an effect on the measured flame temperature**
 - 1/16” sheathed TC’s had the highest measured temperature, although their accuracy degrades quickly
 - 1/8” sheathed TC’s had a lower temperature measurement than both old and new 1/16” TC’s
 - 1/8” exposed junction TC’s had the lowest temperature measurement of all TC’s
- **Although there was an average flame temperature variation of about 100°F, the burner settings remained constant (same flame for all tests)**
 - Specification of an “absolute” flame temperature is not the proper way to define the severity of the flame
 - Measured flame temperature should be used as a guide, and should have broad tolerance, i.e. 2000°F ± 150°F when measured with a specified TC type at a specified location in flame
 - Burner performance should be determined through comparative testing of materials or components
 - FAR’s use performance of steel and aluminum to define fireproof and fire resistant

Next Steps

- **Perform comparative testing between a calibrated Park DPL 3400 burner and a 2.0 gph NexGen burner**
 - Use metallic components, hoses, firewalls for comparative testing
 - Perform round-robin style testing with different burners and labs
 - Park DPL 3400
 - NexGen burners
 - Propane burners
- **Develop guidance material that includes the NexGen burner**
 - Harmonization with EASA and other regulatory agencies critical to FAA efforts

Questions?

Contact:

Robert Ochs

DOT/FAA Tech Center

BLDG 287

Atlantic City Int'l Airport

NJ 08405

robert.ochs@faa.gov

1 609 485 4651

