

Burnthrough Round Robin

Update

Presented to: IAMFTWG

By: Robert I Ochs

Date: October 30 2017



**Federal Aviation
Administration**

Introduction

- **Insulation burnthrough test method being evaluated for within lab and lab to lab consistency**
 - NexGen burner
 - 2 configurations
 - PAN felt material
 - Good repeatability for BT time



2017 Comparative Test Series: In Progress

- **Participation by 11 labs across 3 continents**

1. Accufleet – USA
2. Airbus – Germany
3. Boeing – USA
4. DGA – France
5. Embraer – Brazil
6. FAATC – USA
7. Govmark – USA
8. Jehier – France
9. Rescoll – France
10. Resonate – N. Ireland
11. Triumph – USA

- **Each lab shipped samples for two-part test series**
 - 10 PAN-8579 9 oz/yd² felt samples for picture frame testing
 - 10 PAN-8611 16 oz/yd² felt samples for picture frame testing
 - 6 Brook One BO856B-II thermal acoustic insulation blankets for test rig testing
- **Testing with original stator (with igniters and wires)**
 - 5 PAN-8579
 - 5 PAN-8611
 - 6 BO856B-II (3 tests worth)
- **Testing with new stator (no igniters or wires)**
 - 5 PAN-8579
 - 5 PAN-8611
- **Comprehensive testing instructions e-mailed to each lab**

Phase 1 Results – 8 of 11 Labs Reporting

8579 Average Burnthrough Times

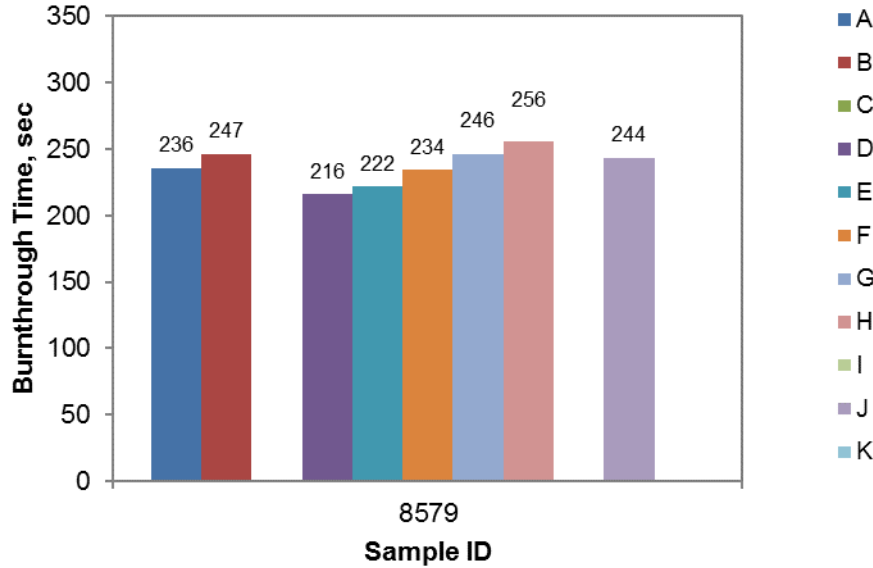

8611 Average Burnthrough Times

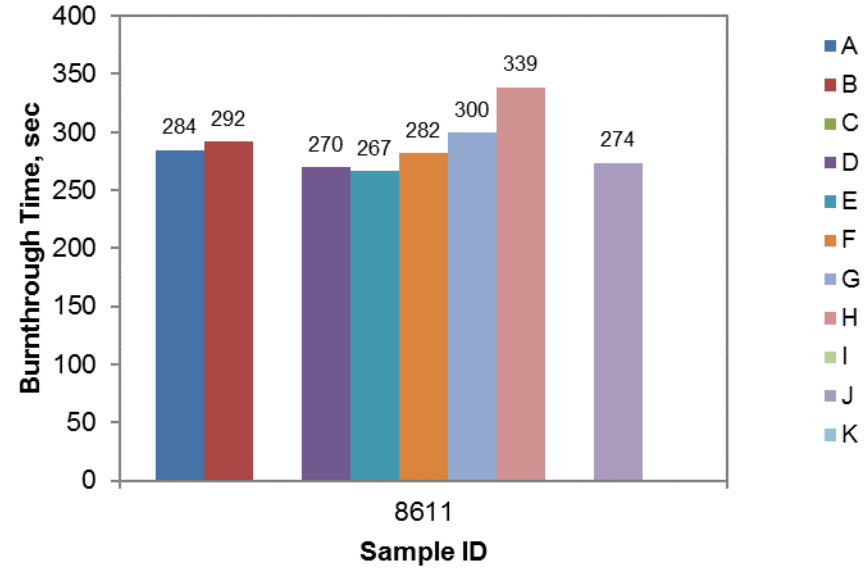

Note: Lab H results 325, 325, n/a, 318, 386

8579 Burnthrough Times

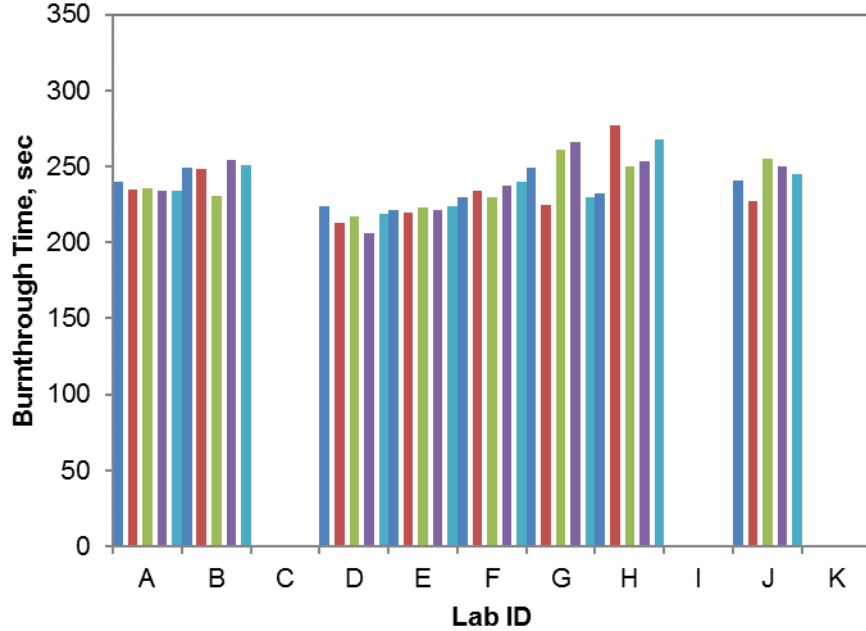

Across All Tests At All Labs
Average BT: 237.5 s
Std Dev: 15.9 s
% Std Dev: 6.7%

8611 Burnthrough Times

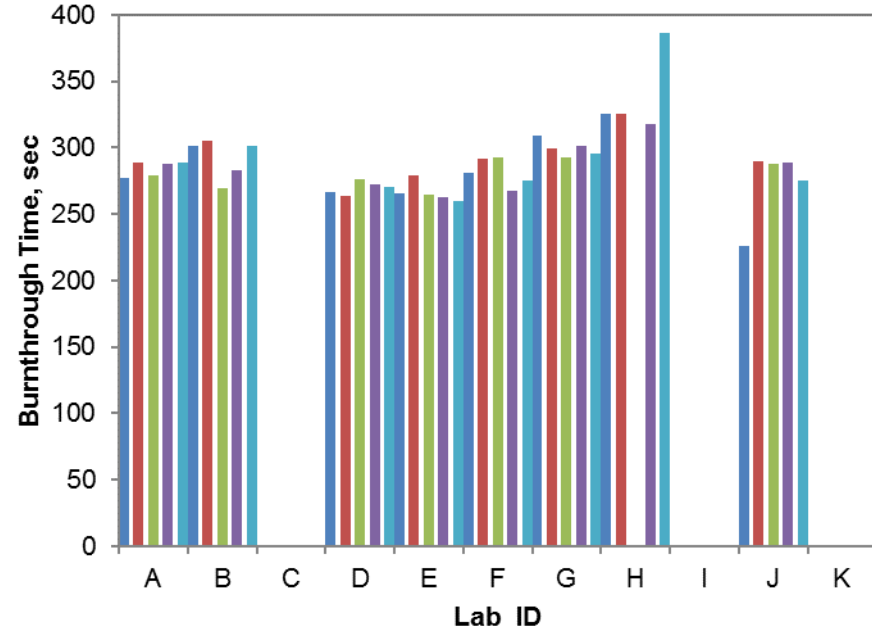

Across All Tests At All Labs
Average BT: 287 s
Std Dev: 25.2 s
% Std Dev: 8.8%



Phase 1 Histograms

8579

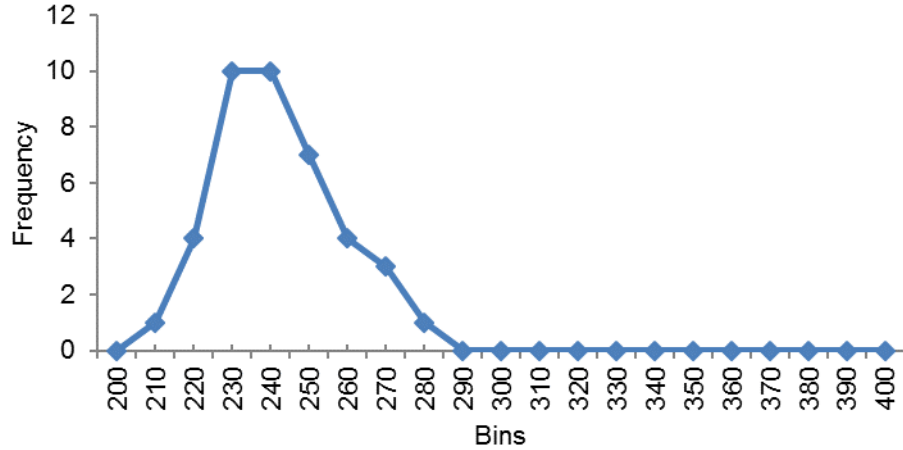

8611

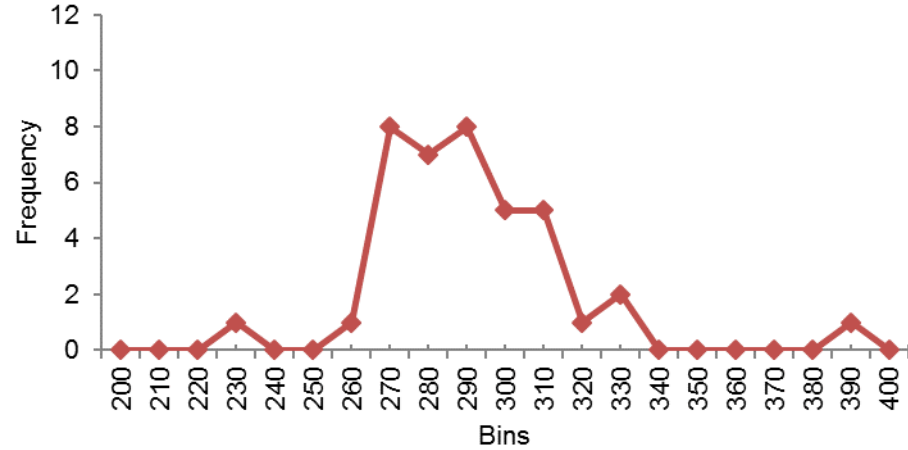

Insulation Blanket Burnthrough Tests

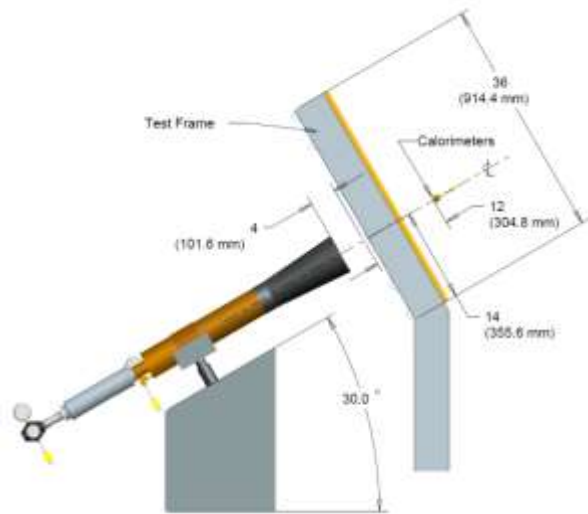

Brook One BO856B-II Thermal Acoustic Insulation Blankets

Lab A

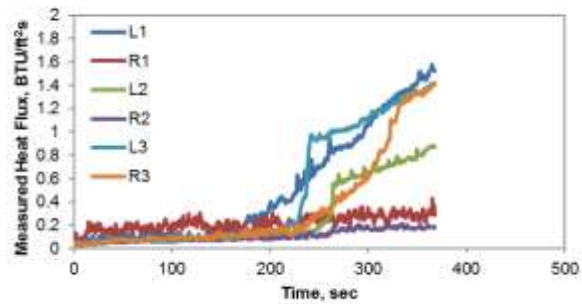

Lab E

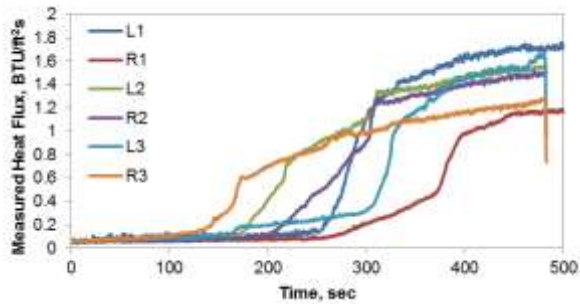

Lab B

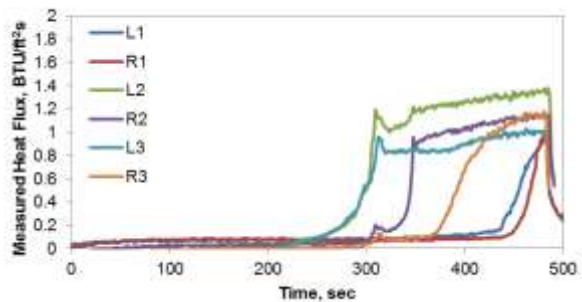

Lab F

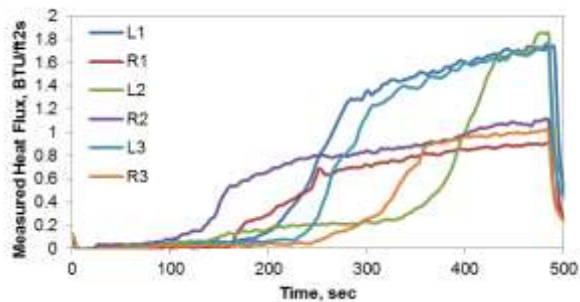

Lab H

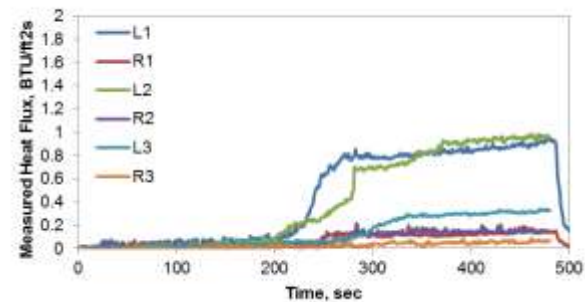

Lab D

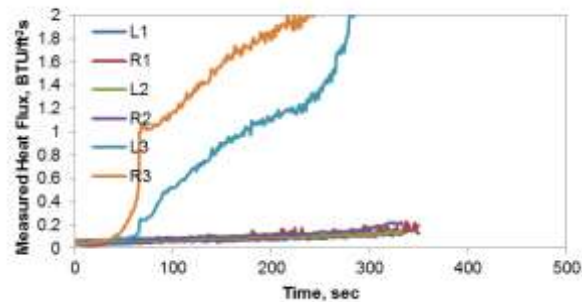

Lab G

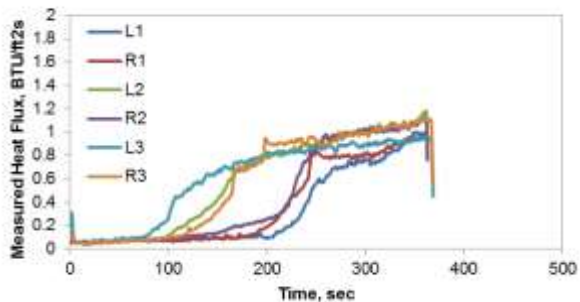

Lab J

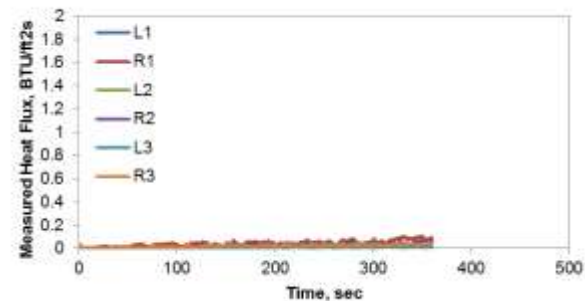

Phase 1 Summary

- **8 out of 11 labs have submitted results**
- **So far, data looks good**
 - ~7% Std Dev for 8579
 - ~9% Std Dev for 8611
 - Burnthrough blankets below 2.0 BTU/ft²s during 4-minute test at all labs (depending on slit in back blanket)

Phase 2

- Phase 2 differs from Phase 1 in the following manner:
 - The new ignitorless stator is used in place of the original stator
 - The inlet air pressure is increased from 60 psig to 65 psig
 - Only PAN materials are tested (no full-sized blanket tests)
 - 5 PAN-8579
 - 5 PAN-8611

Stator and Turbulator Configuration

The stator slides onto the fuel rail, is oriented in the proper direction, and is locked into place with a set screw located at the twelve o'clock position (figure 7-5-15). The turbulator is placed on the end of the draft tube with the tab located at the six o'clock position (figure 7-5-16). The typical configuration positions the face of the stator approximately 2.6875 inches (68.263 mm) from the exit plane of the turbulator (figure 7-5-17). Refer to the Preparation of Apparatus section of this supplement for the exact positioning of the stator and turbulator.



Figure 7-5-15. Location of the Stator on the Fuel Tube



Figure 7-5-16. Position of Turbulator at the end of the Draft Tube

Stator Translational Position

The front face of the stator must be located 2.6875 ± 0.020 inches (68.263 \pm 0.5 mm) from the exit plane of the turbulator (figure 7-5-28). This stator translational position is also 2.3 inches (58.5 mm) from the top of the fuel nozzle.

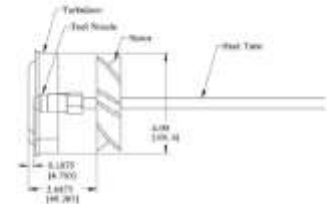

Figure 7-5-28. Fuel Nozzle and Stator Location

Stator Axial Position

The line running through the set screws and geometric center of stator will be used as a reference for properly orienting the rotational position of the stator. The stator must be positioned so the reference line angle is 0 degrees (12 o'clock) from the zero position when looking into the burner draft tube. (figure 7-5-29)

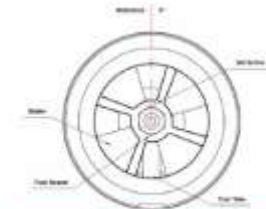
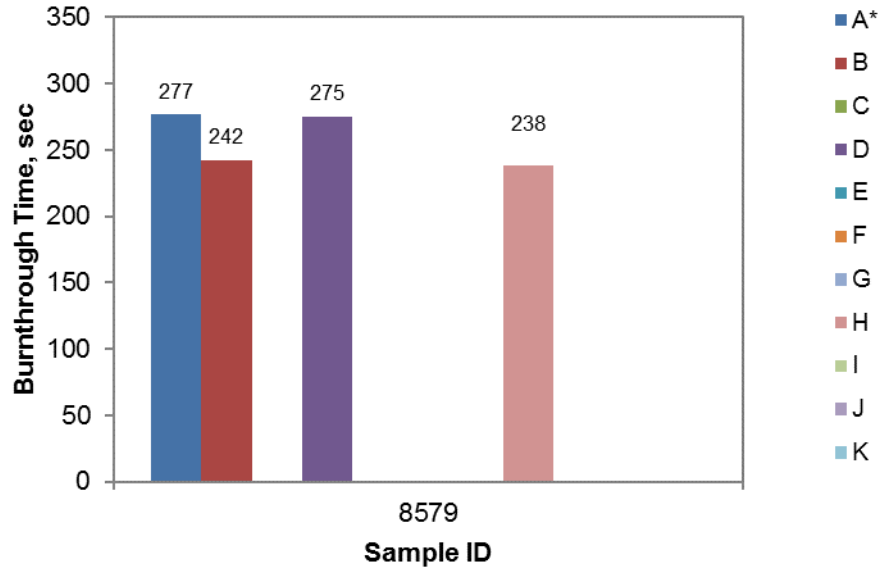

Figure 7-5-29. Stator Axial Position (looking into draft tube)



Phase 2 Results

8579 Average Burnthrough Times



8611 Average Burnthrough Times

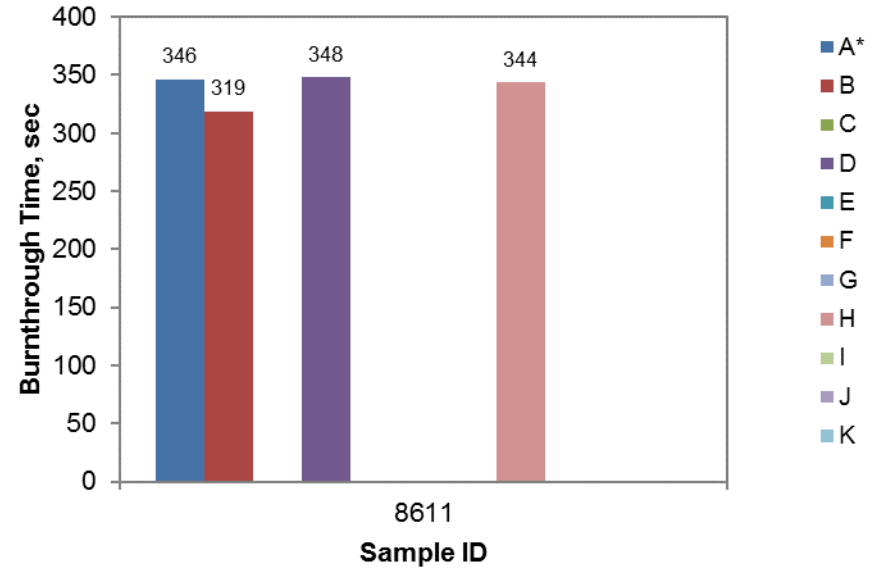

Phase 1 & 2 Comparison - 8579

8579 Average Burnthrough Times

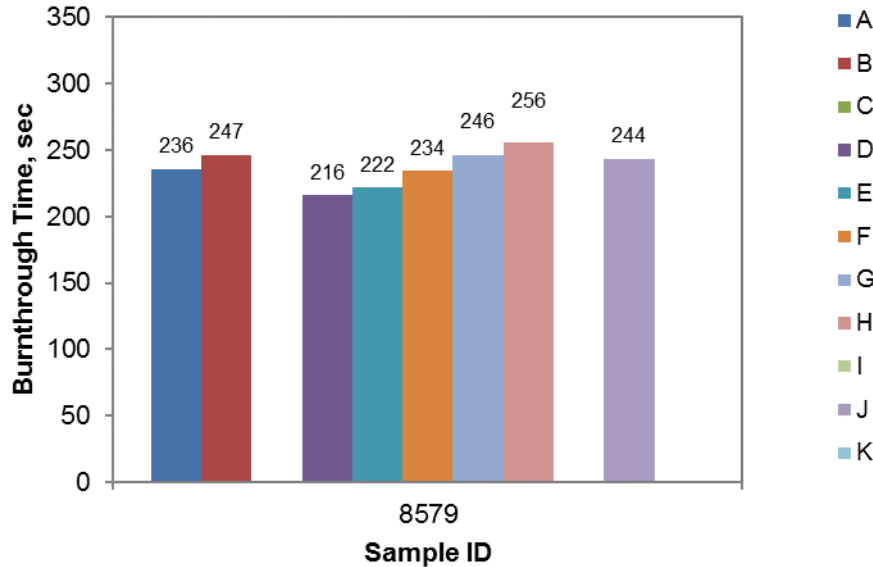

Overall Average BT: 237.5 s
 Std Dev: 15.9 s
 % Std Dev: 6.7%

8579 Average Burnthrough Times

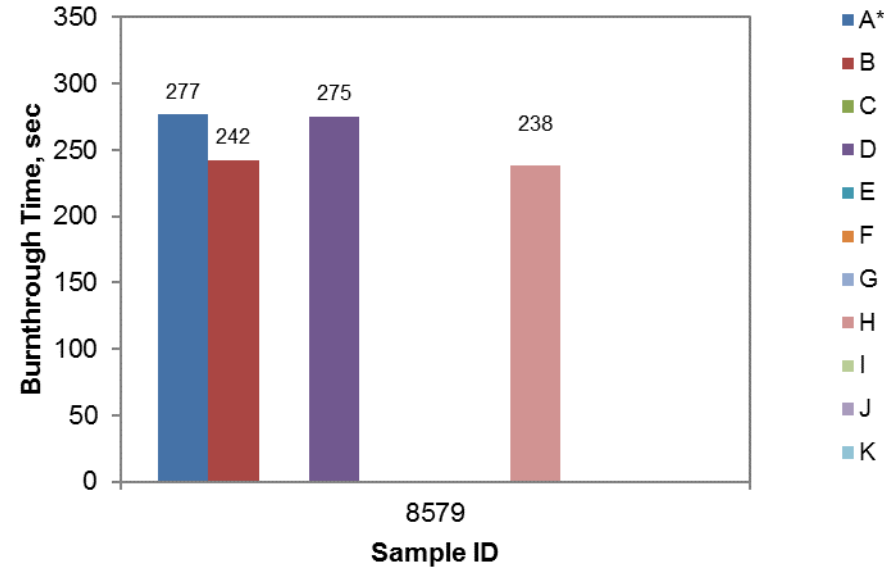

Overall Average BT: 256.2 s
 Std Dev: 20.1 s
 % Std Dev: 7.8%

Phase 1 & 2 Comparison - 8611

8611 Average Burnthrough Times

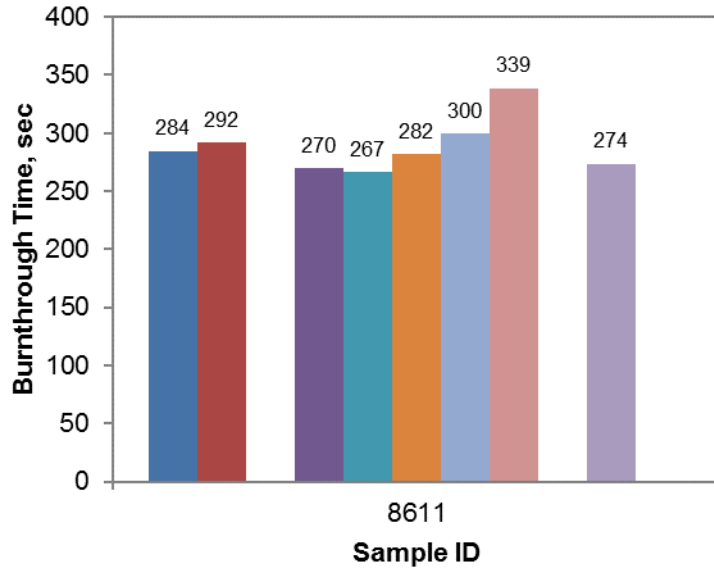

Overall Average BT: 287 s
 Std Dev: 25.2 s
 % Std Dev: 8.8%

8611 Average Burnthrough Times

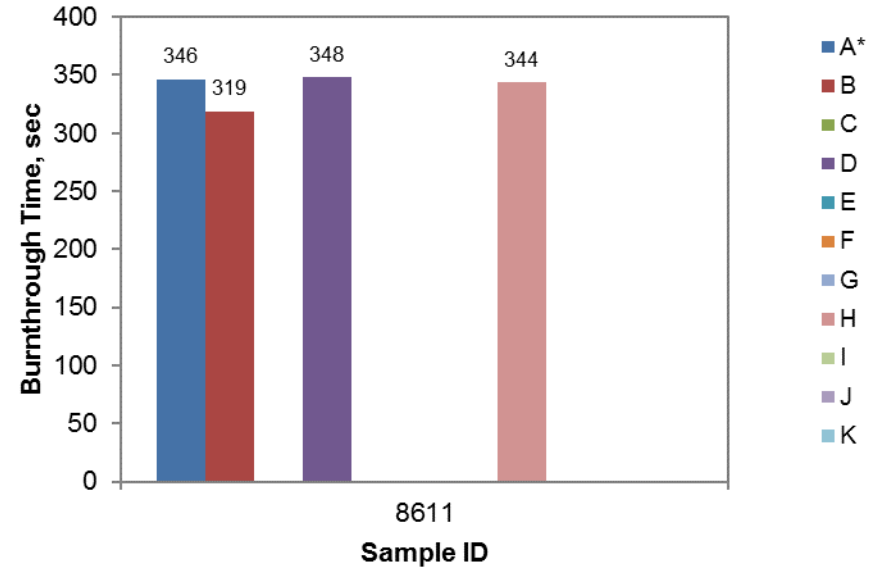

Overall Average BT: 337.8 s
 Std Dev: 18.8 s
 % Std Dev: 5.6%

Phase 1 & 2 Histogram Comparison

8579

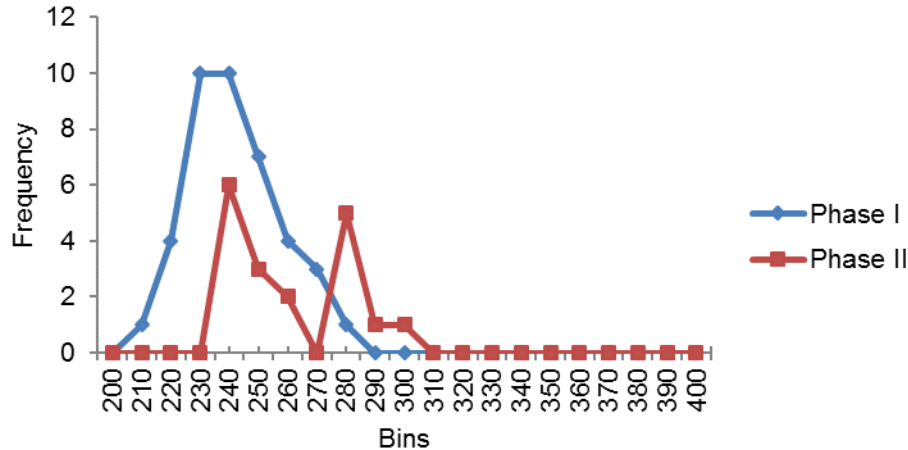

8611

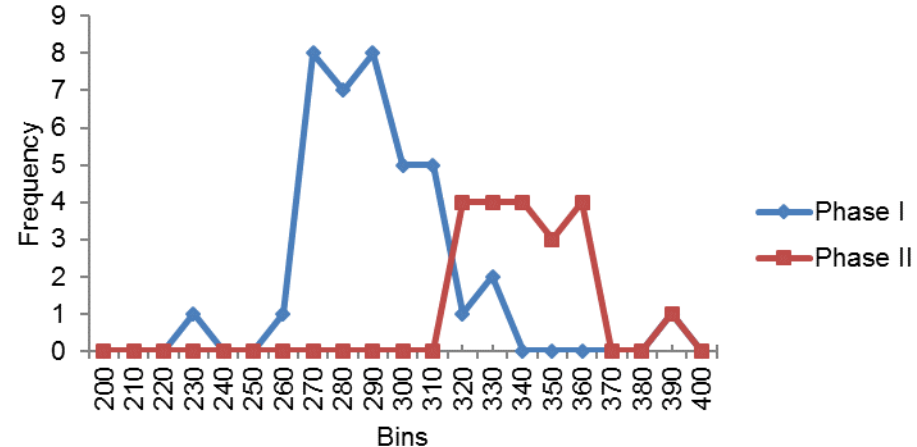

Phase 2 Summary

- 4 labs have submitted results
- Some labs don't have necessary equipment (new stator)
- One lab (A*) ran at 60 psig instead of 65 psig by accident
- Comparing Phase 1 & 2 shows that the new configuration is trending towards longer burnthrough times
 - More evident with 8611