

Chapter 26 Test Method to Determine the Flammability and Flame Propagation Characteristics of Magnesium Alloy

26.1 Scope

26.1.1 Applicability

This test method evaluates the ignition resistance and flammability of magnesium alloy when used in the construction of aircraft cabin components by using an electrically powered radiant panel to show the material adequately self-extinguishes if ignited during an inflight fire.

26.2 Definitions

26.2.1 Magnesium Alloy

A magnesium alloy is defined as any solid form of magnesium containing a variety of alloying materials (e.g., zinc) or rare-earth elements (e.g. yttrium). Any component or material containing more than 10% elemental magnesium by weight shall be considered a magnesium alloy.

26.2.2 Sample Set

A sample set consists of three or more replicate test samples of a particular magnesium alloy used in the construction of an aircraft cabin component.

26.2.3 Flame Impingement Time

Flame Impingement time is the length of time the pilot burner flame is applied to the sample. The ignition time for this test is 120 seconds.

26.2.4 Zero Position

The zero position is the pilot burner application point on the test sample, which is level with the top surface of the sliding platform upper flange. The zero position coordinates are centerline (± 0.25 inches) with the sliding platform opening (front to back) and 4.5 ± 0.5 inches (102 ± 13 mm) from the outside right edge of the platform frame.

26.2.5 Melting

Melting is defined as the point when the sample becomes elastic enough that a significant portion of the sample breaks free and falls from the sample holder. Bending, warping, or sagging alone does not constitute melting.

Occasionally a material may exhibit “flashing” behavior. Flames appear on the test sample some distance away from the zero position (beyond the allowable limit). This is considered ignition.

26.2.6 Ignition

Ignition is defined as the first observation of sparking of the magnesium alloy sample when subjected to the pilot burner. The point of ignition is typically a very bright, intense, blue-white flame that can be differentiated from the surrounding yellow-orange flames being produced by the pilot burner. Ignition is often times the precursor to burning, in which the material experiences sustained ignition.

26.2.7 Burning

Burning (sustained ignition) is defined as an ignition lasting for 10 consecutive seconds (i.e., the start time of an ignition lasting for 10 seconds or more shall be considered the beginning of the burning period, in the event that ignition stops and then re-starts). For example, if ignition starts and goes for 8 seconds then stops, and re-ignites 5 seconds later, the official start of ignition is at the beginning of the re-ignition, and the initial 8 seconds is ignored.

26.2.8 Weight Loss

The sample weight loss is the amount of weight a sample loses during exposure to the pilot burner and radiant heat. Molten pieces of the test sample must be retrieved from the surface of the ceramic board upon which the sample holder rests following test completion once sufficient cooling has taken place. Molten/resolidified pieces of the test sample must be blown off with compressed air, to eliminate the inclusion of oxidized material or ceramic board during the final weight measurement. Molten/resolidified pieces of magnesium alloy are distinguishable from oxidized material in that the magnesium alloy cannot be crushed with simple hand tools such as pliers. Oxidized material is easily crushable. The percentage weight loss for a sample is defined as the pre-test weight of the sample less the post-test weight of the sample and any droppings, expressed as the percentage of the pre-test weight.

26.2.9 Radiant Heat Source

The radiant heat source is an electric panel having six 3-inch (76.2 mm) wide emitter strips (see section 26.3.2 Electric Radiant Heat Source).

26.2.10 Test Series

A series of tests conducted between chamber calibration and system recheck (see sections 26.5.2 Zero Position Calibration and 26.6.3 System Recheck Procedure).

26.2.11 NIST

The National Institute of Standards and Technology (USA).

26.2.12 NIST Traceability

A calibration entity using NIST traceable calibration instrumentation.

26.2.13 Heat Flux

The intensity of the thermal environment to which the sample is exposed when burned. In this test method, the total heat flux is 1.5 BTU/ft²sec (1.7 W/cm²).

26.3 Test Apparatus

26.3.1 Test Chamber

Tests must be conducted in a radiant panel test chamber as shown in figure 26-1. The test chamber is 55 ± 1 inch (1397 ± 25.4 mm) wide, 20 ± 1 inch (508 ± 25.4 mm) deep (front to back), and 29 ± 1 inch (737 ± 25.4 mm) high from the top of the sliding platform to the top of the chamber frame. All dimensions are taken from the inside of the insulated walls.

The sides, back, and top of the chamber must be insulated with 0.5-inch-thick (12.7 mm), high-temperature insulation material. On the front side, a draft-free, high-temperature glass viewing window must be installed. The window is 9 ± 3 inches (229 ± 76 mm) high by 48 ± 4 inches (1219 ± 102 mm) long. The sliding platform drawer sits below the viewing window.

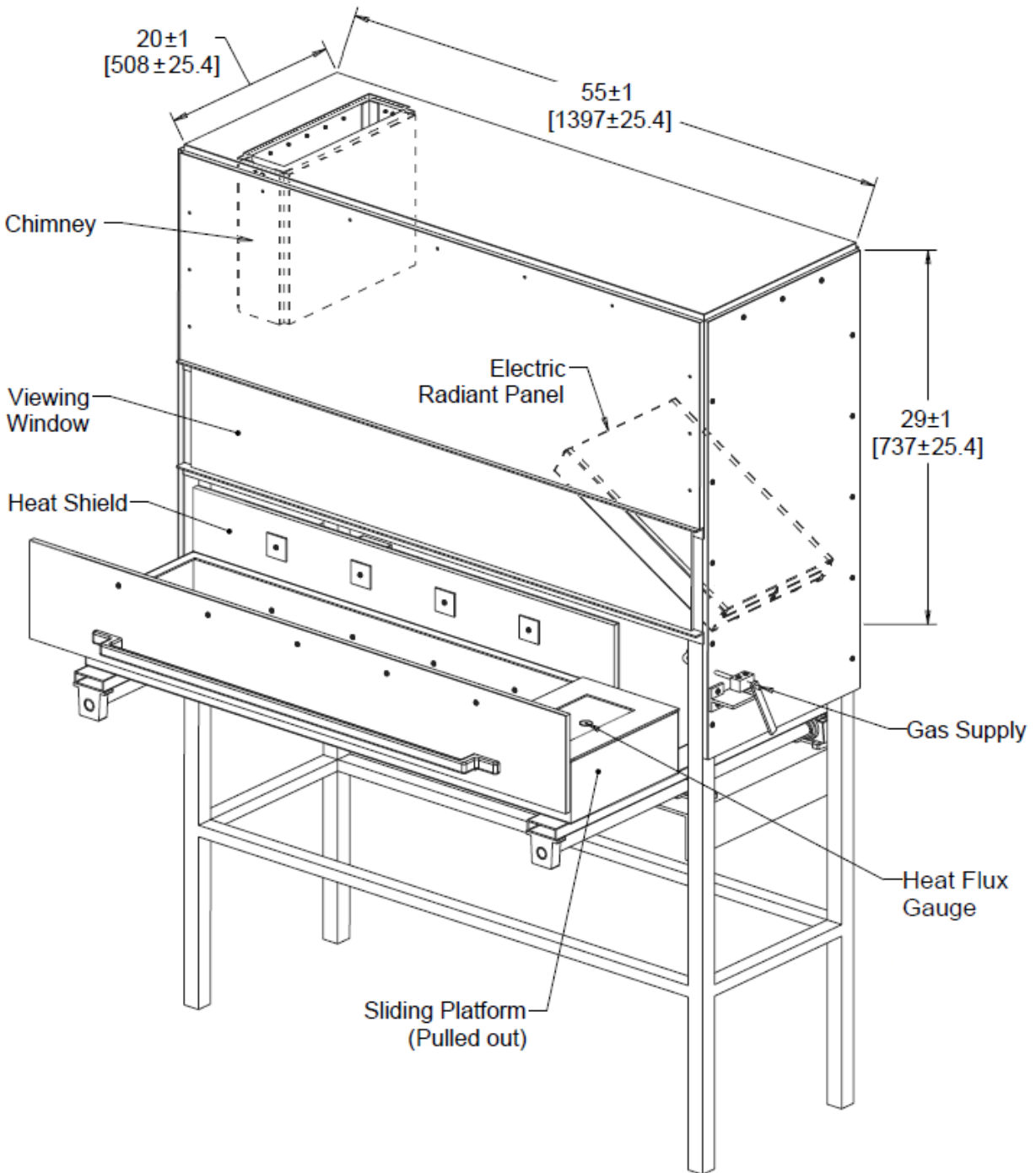
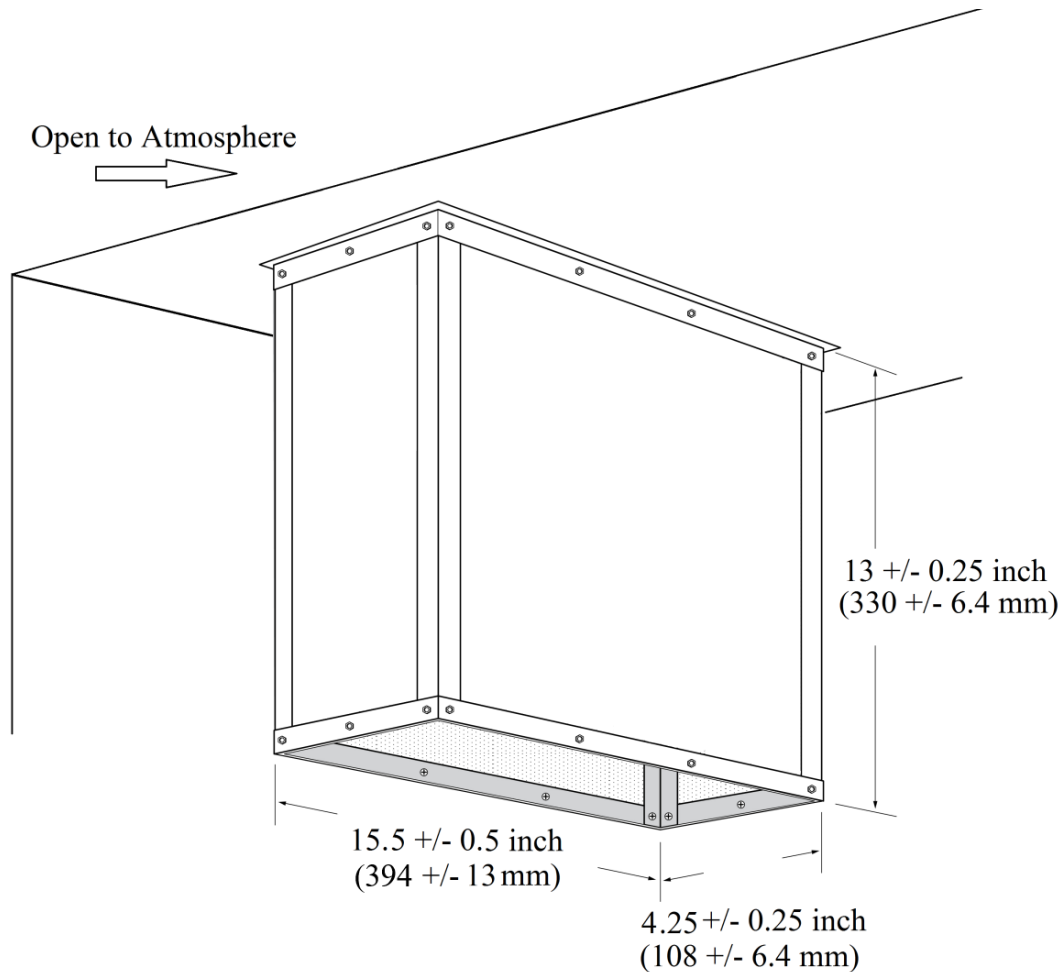

Figure 26-1. Test chamber

The chamber must have an internal chimney that extends to and terminates at the top of the chamber. The chimney is located at the opposite end of the chamber from the radiant heat source (see figure 26-2). Test results can be significantly influenced by the condition of the chimney in the test chamber, which must always be open and clear of obstruction. The test chamber should be located under an exhaust hood to facilitate clearing exhaust smoke during each test.



- 0.125 inch (3.2 mm) Angle Iron (8 places)
- 0.125 inch (3.2 mm) Flat Stock (4 places)
- 0.5 inch (13 mm) Insulation Board (4 places)
- 0.0625 inch (1.6 mm) Sheet Metal (4 places)

Figure 26-2. Interior view of internal chimney

26.3.1.1 Air Draft Check

A draft check must be completed periodically if the test chamber is physically moved or if the exhaust system has been changed. Ensure that the chamber is draft free prior to turning on the power to the radiant heat source. To verify this, measure the airflow above the internal chimney with an anemometer device to ensure there is no airflow. Alternatively, an incense cone or other smoke-producing item can be placed on the sliding platform at the zero position with the platform drawer closed.

NOTE: the sliding platform must have insulation boards covering the entire length of the platform for either method of draft checking.

Observe the smoke behavior. If the smoke rises vertically without any drift, it can be regarded as draft-free. If testing is performed with an exhaust hood running, the airflow check must be performed with the exhaust hood on.

26.3.2 Electric Radiant Heat Source

The electric panel must have six 3-inch (76.2-mm) wide emitter strips, as shown in figure 26-3. The emitter strips must be perpendicular to the length of the panel. The panel must have a radiation surface of 12.6 by 18.75 inches (321 by 476 mm) and be capable of operating continuously at the typical temperature range required to maintain the specified heat flux. The panel surface should be kept clean using a soft bristle brush or soft cloth. A plastic scraper can be used if any debris sticks to the surface. Never use anything metal, such as a wire brush, to clean the panel surface.

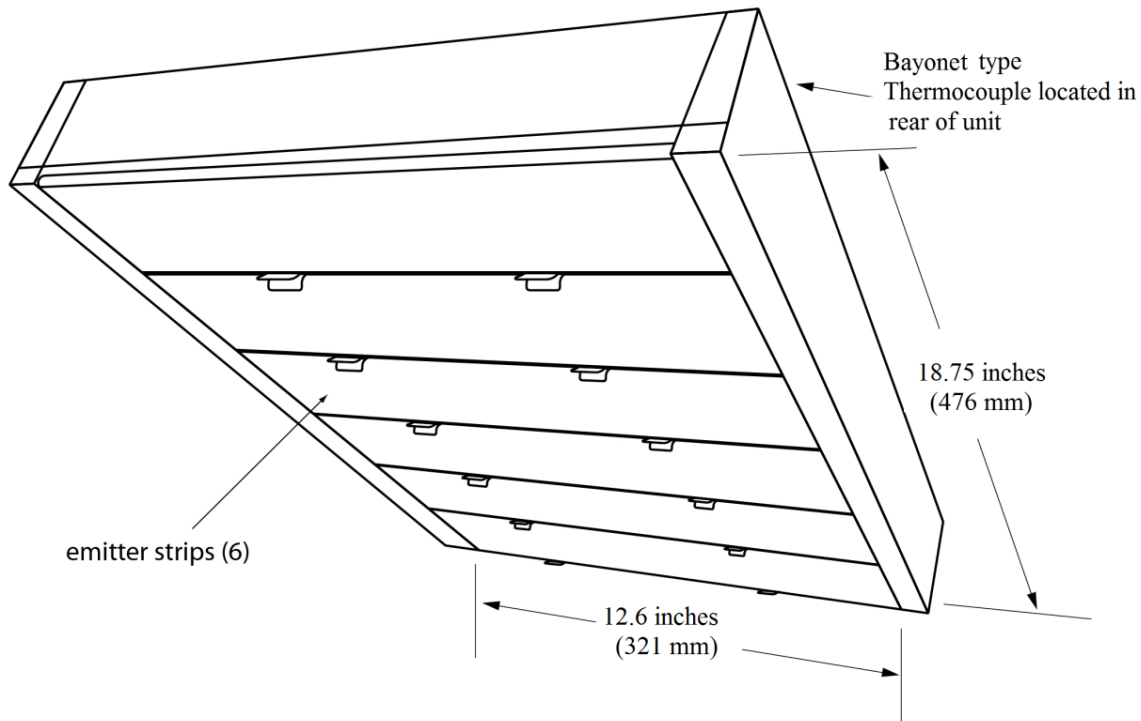

Figure 26-3. Electric radiant panel

26.3.2.1 Electric Radiant Panel Placement

The electric panel must be mounted in the test chamber at $30 \pm 1^\circ$ to the horizontal sample plane and 7.5 ± 0.125 inches (191 ± 3 mm) above the zero position.

26.3.3 Sample Holding System

The drawer (also called the sliding platform) serves as the housing for test sample placement in a fixed and level position (see figure 26-4). The drawer must be at least 2 inches (51 mm)

deep and may be up to 6 inches (152 mm) deep. It may be necessary to use shims and multiple sheets of insulation board to obtain the correct height for a magnesium alloy sample to be level with the bottom surface of the sliding platform upper flange. The entire opening on the inside of the drawer must be covered during testing to prevent convective airflow.

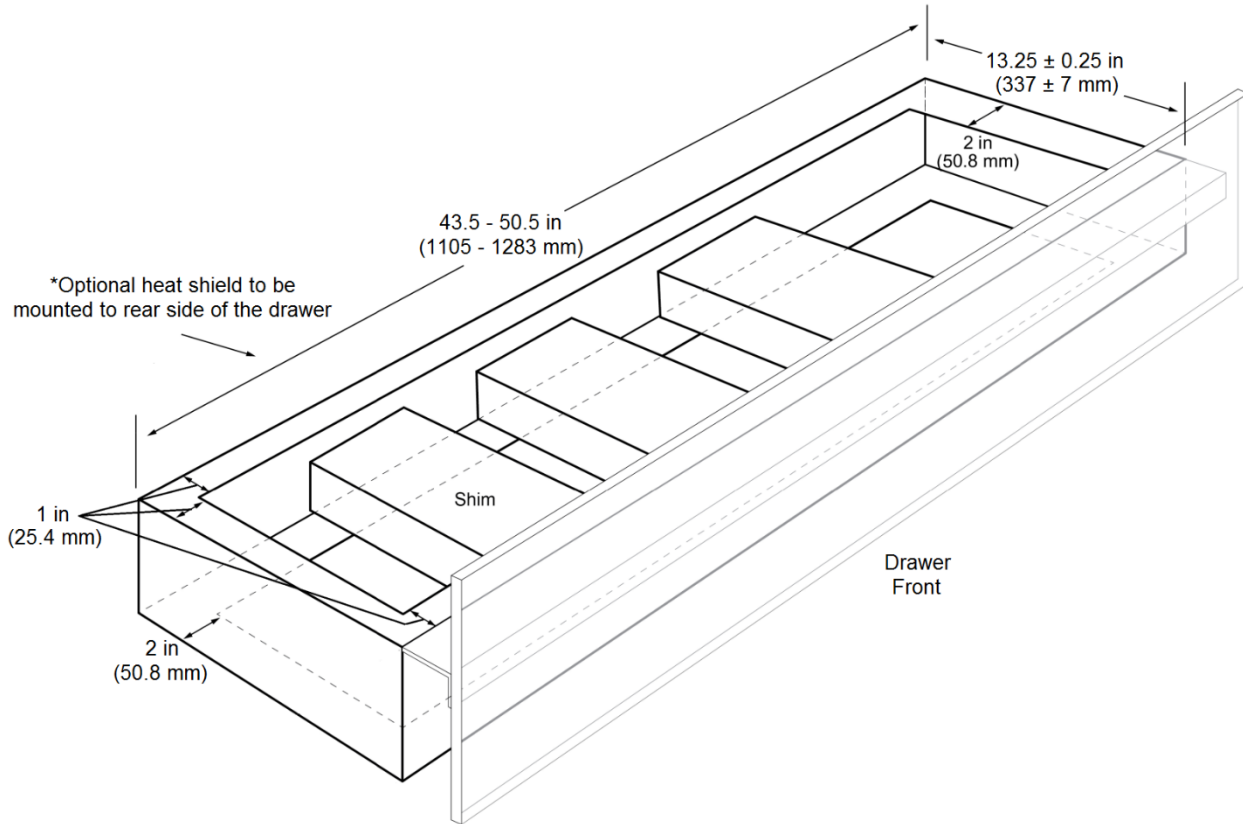
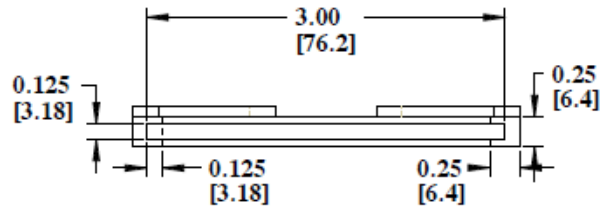

Figure 26-4. Sliding platform

26.3.3.1 Sample Holder

A sample holding frame is required and must secure the sample in place during testing (see figure 26-5). The thin magnesium alloy sample slides into the slotted sample holder in order to suspend the sample above the bottom surface plane of the holder. The bottom surface of the holder frame (horizontal) sits on top of several layers of insulation board. It may be necessary to adjust the sample up or down to maintain the 7.5 ± 0.125 -inch (191 ± 3 -mm) distance from the sample surface to the radiant panel at the zero position.

Some samples tend to warp during testing, which can alter the height of the exposed sample with respect to the pilot flame and radiant heating panel. Test sample warpage must be monitored throughout the test; excessive sample warpage such that the sample surface moves away from the heating surfaces should be considered a non-test.



SCALE 1.750

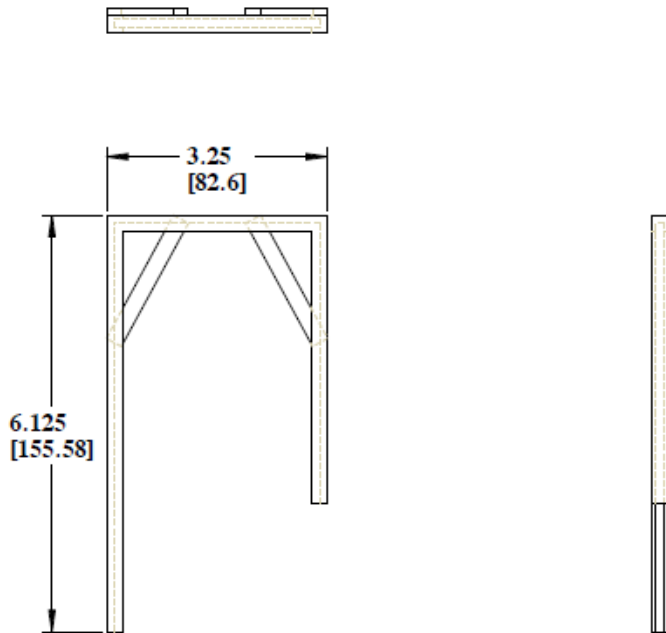

Figure 26-5. Standard sample holder frame

26.3.3.2 Sample Holder Alignment Tool

An alignment tool must be fabricated of a thin, rigid material for properly locating the sample holder and sample on top of the insulation boards. The alignment tool must center the sample holder with respect to the radiant panel as shown in figure 26-6. Once the sample holder is located in the correct position, it is removed prior to testing.

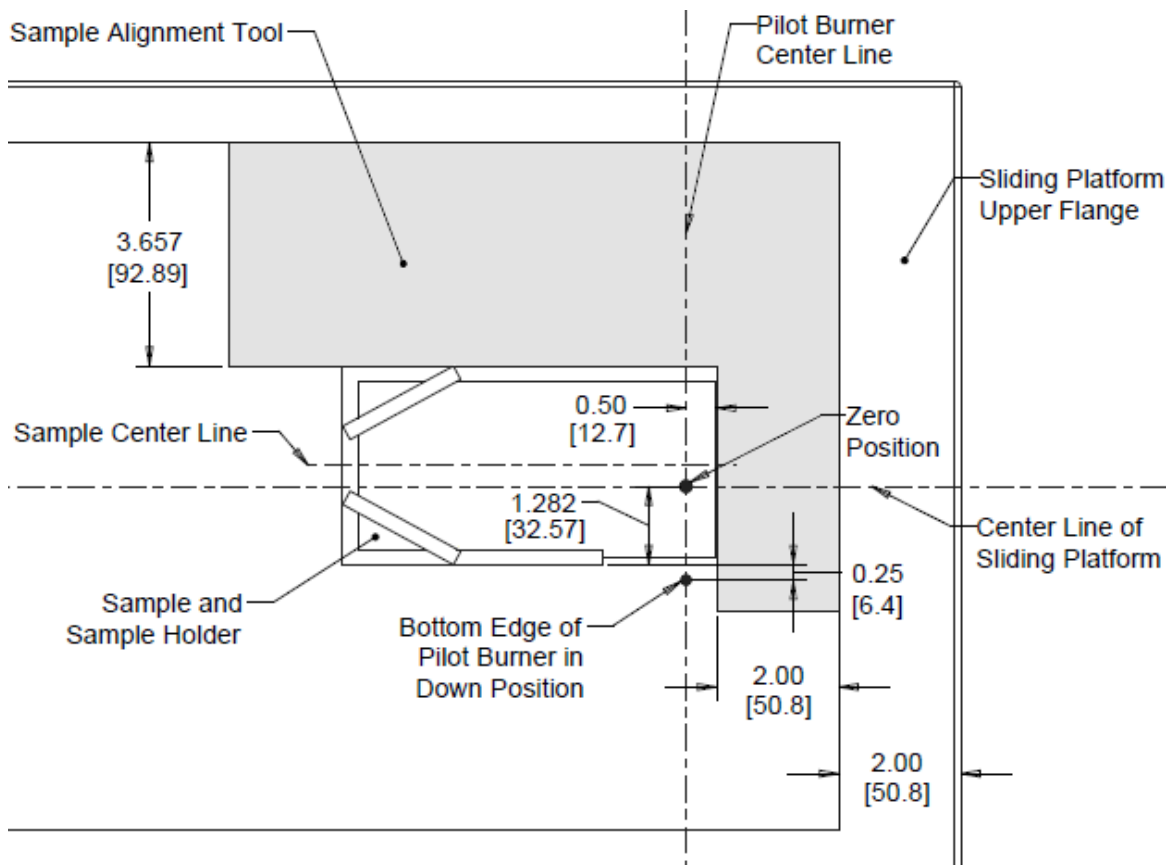

Figure 26-6. Sample holder alignment tool located on sliding drawer

NOTE: Figure 26-6 is an example of an alignment tool for an individual radiant panel apparatus. Small adjustments to the dimensions may be necessary to align the sample correctly with the pilot burner in each individual apparatus.

26.3.4 Pilot Burner

The pilot burner used to ignite the sample must be a commercial propane Venturi torch with an axially symmetric burner tip and a propane supply tube having an orifice diameter of 0.006 inches (0.15 mm) (see figure B6-7). The length of the burner tube must be 2.875 inches (73 mm). The propane flow must be adjusted via gas pressure through an inline regulator to produce a blue inner cone length of 0.75 inches (19 mm). A removable 0.75-inch (19 mm) guide, such as a thin strip of metal, may be connected to the top of the burner to aid in setting the flame length. The overall flame length must be approximately 5 inches long (127 mm) (see figure 26-8). An optional high-temperature glass viewing window located on the left wall of the chamber is permitted to ensure proper flame length if it is no larger than 6 inches by 6 inches (152 by 152 mm).

Provisions must be made to move the burner from the test position so the flame is horizontal and at least 2 inches (50.8 mm) above the sample plane (standby position). Do not allow the flame to impinge on the radiant panel.

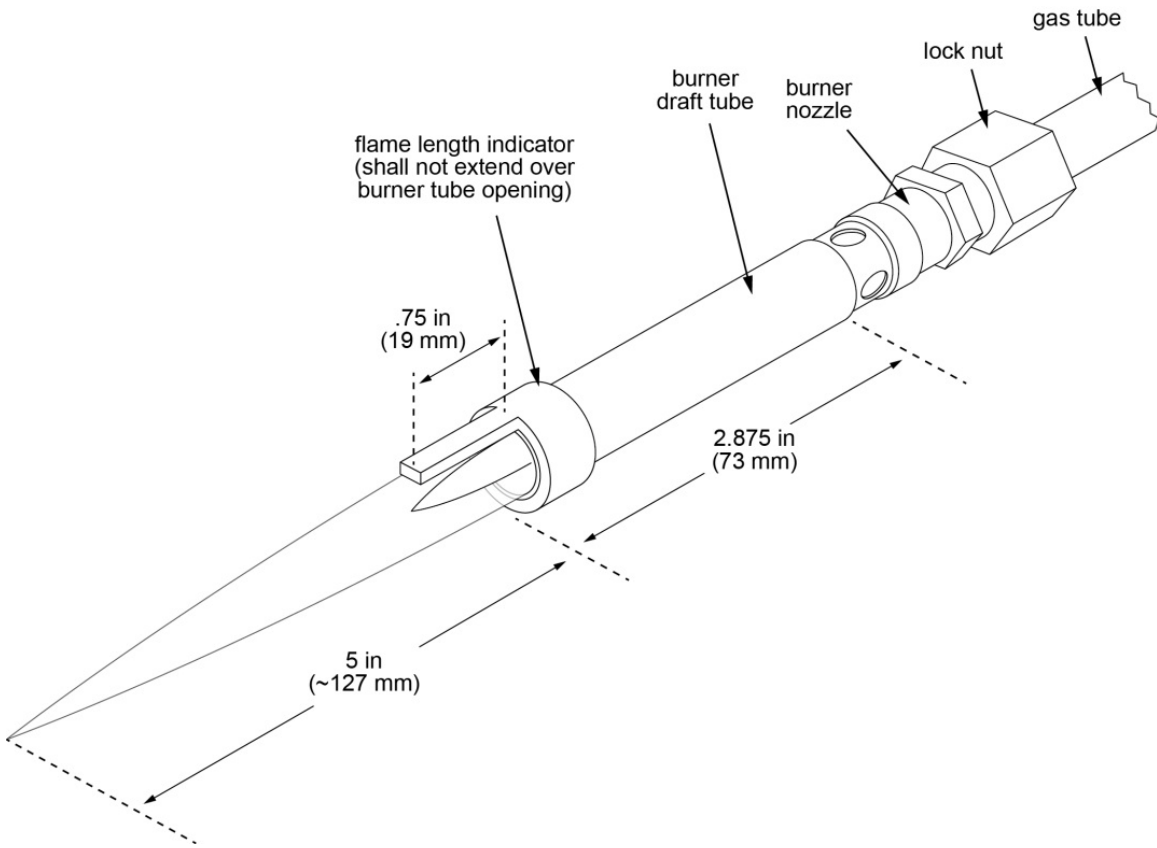

Figure 26-7. Propane venturi torch (pilot burner)

26.3.5 Chamber Temperature Thermocouple

A chamber temperature thermocouple is recommended as a third point of reference for overall system health monitoring. It is used in conjunction with the heat-flux measurement and power-controller setpoint. The thermocouple must be a 0.0625-inch (1.59 mm) diameter, stainless-steel, jacketed Type K (Chromel-Alumel) thermocouple, located inside the chamber through a small hole drilled through the back wall.

Once heat flux is determined and the system is calibrated and ready for testing, the nominal operating range is typically $450 \pm 100^\circ\text{F}$ ($232 \pm 55^\circ\text{C}$). This temperature should remain consistent ($\pm 5\%$) in day-to-day testing for an individual machine, but may vary much more across different machines.

26.3.6 Calibration Assembly

26.3.6.1 Heat-Flux Gauge

A water-cooled, Gardon-type heat-flux gauge (HFG) must be used to determine the total heat-flux at three positions within the chamber. The HFG cooling water temperature, pressure, and flow shall be maintained within the manufacturer's recommendations. Ensure no condensation occurs on the gauge surface at any time (often caused by cooling water being too cold).

The HFG must have a thin, full-faced, opaque coating of high-temperature, high-emissivity, ultra-flat black paint. The sensitivity of the gauge is a function of the surface condition. Changes in the coating may cause drift in the overall characteristics of the gauge. Regularly inspect the measuring surface for physical damage or dust particles that may have accumulated. Cleaning can be accomplished by gently wiping a soft, water-dampened sponge across the sensor face. Damage done to the coating during the cleaning process will affect the measurement accuracy of the sensor. To maintain accuracy, the measuring surface must be recoated at regular intervals, followed by annual recalibration.

26.3.6.2 HFG Calibration Fixture

The center of an HFG must be mounted in the zero position, as defined in 26.5.2, to determine total heat flux on test samples. The HFG must be mounted in a supporting device protruding through 0.5-inch-thick (12.7 mm) rigid refractory board. Alignment features may be added to help secure the fixture in the correct position. The holder must be constructed so it can be easily moved from one position to the next when conducting a three-position check, or it must be able to measure all three positions at the same time (see section 26.5.4 3 Position Check).

26.3.7 Instrumentation and Equipment

26.3.7.1 Data Acquisition

A computerized data-acquisition system must be used to record the output of the HFG and the chamber thermocouple. The data-acquisition system must be capable of recording the HFG output every second during calibration and calculating a 5-minute average of the data. An acceptable data-acquisition system is a 22-bit, analogue-to-digital converter with an accuracy of 0.02% of the reading. The data-acquisition system must be calibrated annually to NIST traceability.

26.3.7.2 Timing Device

A stopwatch or other device, accurate to ± 1 second per 8 hours (± 3 sec/day), must be used to measure the time of flame application and time when sample begins to burn (sustained ignition). It is acceptable to use an automatic timer for moving the pilot burner in and out of test position. The timing device must be calibrated annually to NIST traceability.

26.3.7.3 Digital Weight Scale

A suitable weight scale must be used to determine the initial and final weights of the test sample, and weight of any molten /resolidified portions of the test sample captured in the

catch pan. The scale must have a resolution of 0.02 lbs (0.01 kgs) and an accuracy of ± 0.02 lbs (± 0.01 kgs).

26.3.7.4 Test Chamber Enclosure

A suitable test chamber enclosure must be used to reduce or eliminate the possibility of test fluctuation due to air movement. The test enclosure must have a minimum floor area of 10 feet by 10 feet (305 by 305 cm).

26.3.7.5 Enclosure Ventilation Hood

The test chamber must have an exhaust system capable of removing the products of combustion expelled during the tests.

26.4 Test Samples

26.4.1 Sample Configuration

Test samples representing the in-service components must be constructed of the identical magnesium-alloy material to be used in service.

26.4.2 Sample Number

A minimum of three samples for each magnesium alloy type used for a design configuration must be prepared for testing. These samples must exclude any surface modifications such as intumescent paints or coatings, or any anodizing processes.

26.4.3 Sample Size

The samples to be tested must measure 3.0 ± 0.03 inches (76.2 ± 0.8 mm) wide by 6 ± 0.06 inches (152.4 ± 1.6 mm) in length by 0.025 ± 0.0063 inches (0.64 ± 0.16 mm) thick.

26.4.4 Sample Finish

A machined surface finish to all faces is required for the test samples (e.g. an average roughness value Ra of less than $1.75 \mu\text{m}$).

26.4.5 Sample Coatings

If a finish coating, anodizing, or other standard aerospace grade surface treatment is used on the magnesium alloy in service, it is sufficient to test the coated materials using the 12-second vertical Bunsen burner test method described in Chapter 1 of this handbook (Vertical Bunsen Burner Test for Cabin and Cargo Compartment Materials). Vertical Bunsen burner test samples must be fabricated with the coating applied to the magnesium alloy substrate that it will be used on in service, using the production process. The test must be conducted using a substrate thickness representative of the thinnest cross section of the in-service component. If the coating/substrate passes in this thickness (critical test configuration), the coating can be

applied to any thicker in-service components of the identical magnesium alloy material without additional testing. Any in-service components having thinner cross sections will require additional vertical Bunsen burner substantiation using that coating/substrate thickness.

26.4.6 Sample Conditioning

Condition test samples at $70 \pm 5^\circ \text{F}$ ($21 \pm 2^\circ \text{C}$) and $55 \pm 10\%$ relative humidity for a minimum of 24 hours prior to testing. It is permissible to remove more than one sample at a time from the conditioning chamber if the samples are placed in a closed container (a plastic bag is acceptable). The samples must be protected from contamination until tested.

26.4.7 Sample Placement

The sample holder must be correctly located (longitudinally) on the sliding platform, in order for proper alignment of the pilot burner onto the test sample (see figure 26-8). As shown, the sample holder must be situated such that the edge of the sample is 0.50 inches to the right of the pilot burner zero position. A sample alignment tool must be fabricated from a rigid material to allow quick and accurate placement of the sample holder onto the sliding drawer. The most practical approach is to fabricate the tool to fit into the upper flange of the sliding drawer, up against the right rear inside corner.

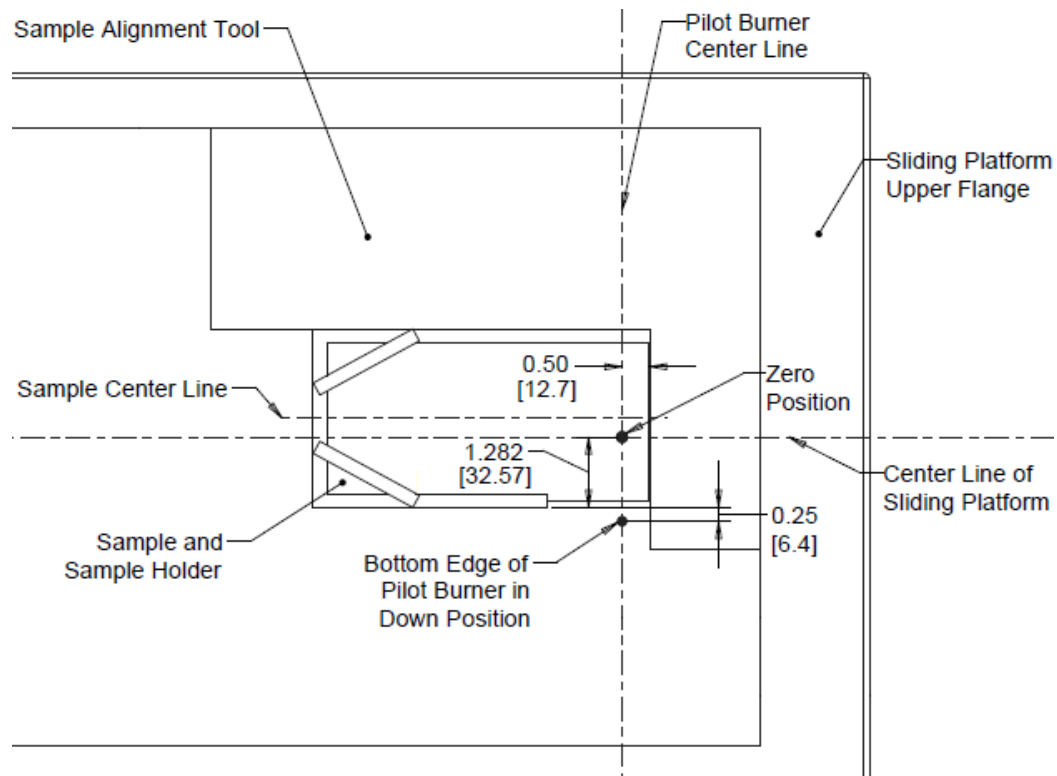

Figure 26-8. Sample holder alignment tool located on sliding drawer

The sample holder must be placed so that the top surface of the sample is level with the top surface of the sliding platform upper flange (see figure 26-9). When placing the sample holder on top of the insulation boards, some adaptation is necessary to precisely position the test sample. It is permissible to use thin shims of sheet metal to bring the top surface up to the correct height, however the shims must be positioned under the uppermost insulation board to prevent heat transfer to any metallic shims. It is critical that the top of the sample be at the proper height in order for the correct exposure of the test sample to the radiant heat source (see section 26.2.4 Zero Position).

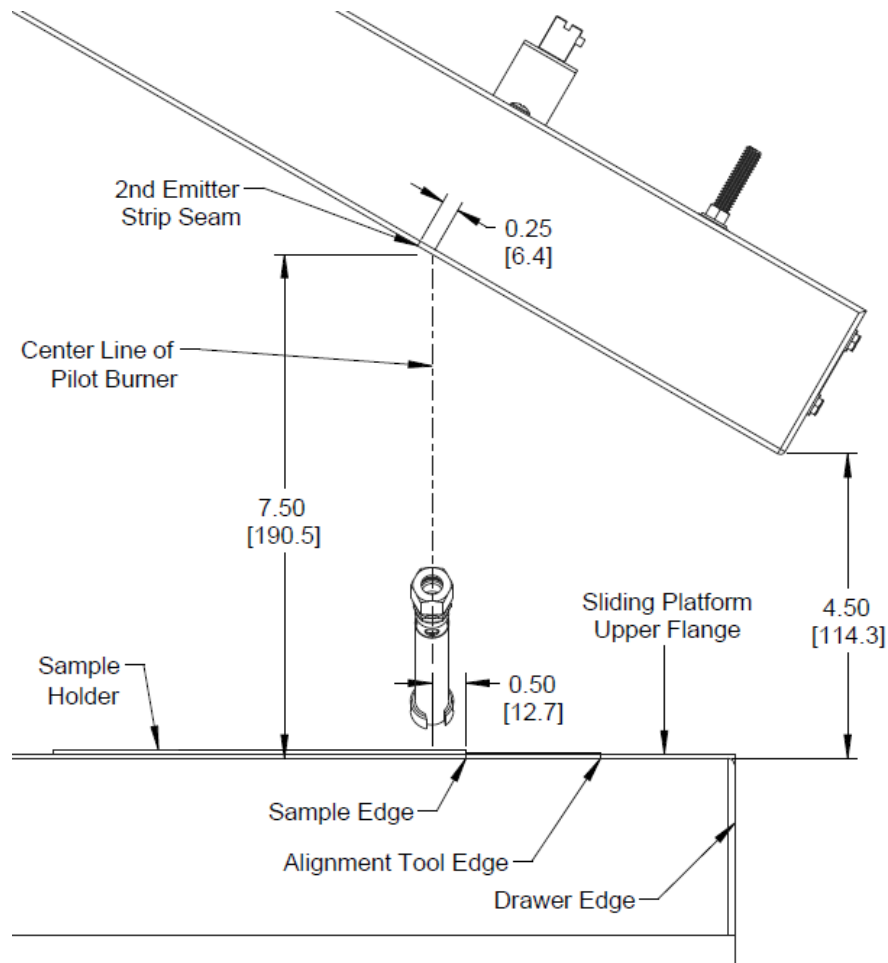

Figure 26-9. Sample holder positioning on sliding drawer

The sample holder alignment tool must also correctly position the sample holder (laterally) so that the sample is centered with respect to the radiant panel above (see figure 26-10). When the sample holder is centered, the lower tip of the end of the pilot burner will be situated 0.25 inches from the edge of the sample holder (pilot burner in the down position).

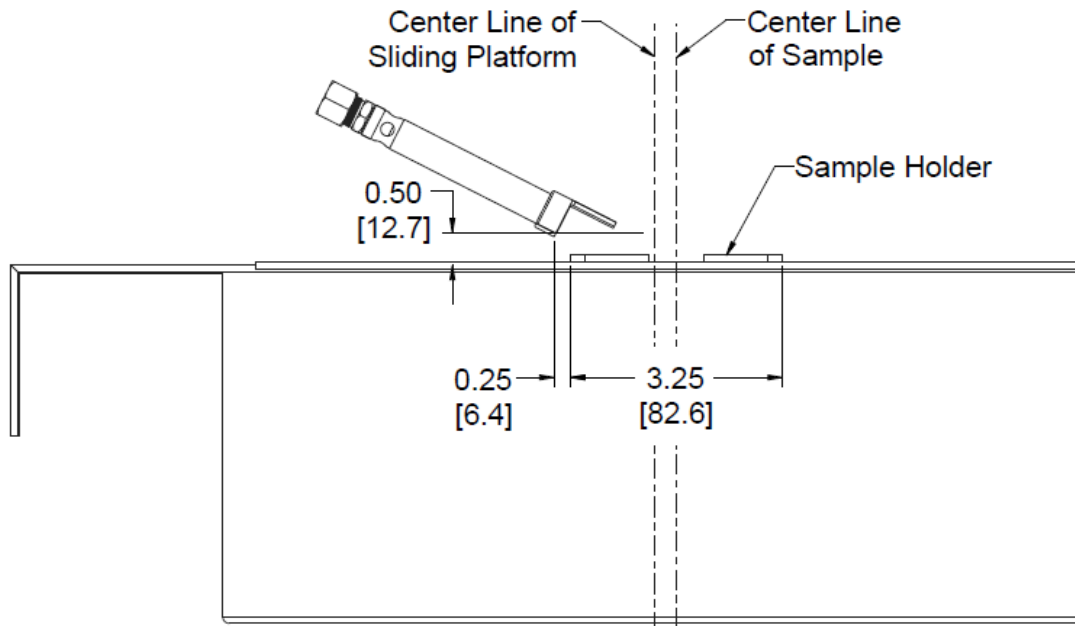

Figure 26-10. End view of sample position on sliding platform

NOTE: Proper alignment tool fabrication and measurement are necessary for each lab because slight variations may exist from one apparatus to another.

26.5 Preparation of Apparatus

26.5.1 General Information

Prior to daily testing, a “Zero Position Calibration” (section 26.5.2) and “System Upset Check” (section 26.5.3) must be conducted. A “Recheck” must be conducted immediately following the completion of a test series to ensure data are valid. If the recheck heat-flux value is not within range, the test data are considered to be invalid (section 26.6.4). Once a recheck is conducted, material testing must be continued within 30 minutes, or the equipment must be allowed to cool to ambient conditions (approximately 1 hour) if testing has been completed. Heat flux must be calculated using a 5-minute rolling average.

Calibration of the test apparatus must be completed no sooner than 25 minutes and no later than 90 minutes after turning the radiant panel on. If calibration is not able to be completed within 90 minutes, it could indicate a problem with the machine and the equipment must be allowed to cool to ambient conditions (approximately 1 hour) before repeating the “Zero Position Calibration” and “System Upset Check” procedure.

NOTE: The actual heat flux generated by the radiant panel has a direct influence on test results. Experiments suggest that variations in heat flux from the ranges specified can influence both the melt time and burn time, although not necessarily in the same way. A slightly higher heat flux might be critical for one parameter, whereas a slightly lower heat flux might be

critical for the other parameter. It is essential that heat flux be maintained as specified in table 26-1.

Table 26-1. Heat-flux ranges for thermal/acoustical insulation test

	W/cm ²			
Range	Zero Position	#1 Position	#2 Position	Recheck
High	1.72	1.73	1.67	1.75
Nominal	1.70	1.70	1.64	1.70
Low	1.69	1.66	1.57	1.64
	BTU/ft ² *sec			
Range	Zero Position	#1 Position	#2 Position	Recheck
High	1.51	1.52	1.47	1.54
Nominal	1.50	1.50	1.44	1.50
Low	1.49	1.46	1.38	1.44

26.5.2 Zero-Position Calibration Procedure

26.5.2.1 Install the HFG calibration fixture at the zero position. Place a sheet of noncombustible material on top of the sliding platform adjacent to the HFG fixture (to the left) to prevent heat loss during calibration. The entire opening of the inside of the drawer must be covered.

26.5.2.2 Ensure the HFG surface is clean, properly aligned, and cooling water is flowing. Close the sliding platform.

26.5.2.3 The pilot burner must be off and in the down position (test position).

26.5.2.4 Begin heating and allow a minimum time period of 25 minutes for equipment to stabilize. The temperature of the radiant panel must reach its set point.

26.5.2.5 Calculate the zero position heat flux using the HFG millivolt signal and its calibration constant, and begin observing a 5-minute rolling average.

26.5.2.6 Once a stable heat flux is determined, adjust the temperature setting as necessary, and restart the 5-minute rolling average. Repeat this process until the zero-position heat flux is within the appropriate range (table 26-1).

26.5.3 System Upset Check

Prior to testing, a system upset check must be completed once the zero-position heat flux is determined to be stable and within tolerance. The heat flux must return to the zero-position range, as specified in table 26-1 during this check.

26.5.3.1 Raise the pilot burner to the standby position.

26.5.3.2 Pull the sliding platform out to its stop and hold open for 30 seconds (simulated material load time).

26.5.3.3 After 30 seconds, close the sliding platform completely.

26.5.3.4 Lower the pilot burner into the test position.

26.5.3.5 Allow the process-controller temperature to return to its original setpoint ($\pm 1^{\circ}\text{F}$).

26.5.3.6 Begin the 5-minute heat flux rolling average calculation.

26.5.3.7 After the 5-minute average heat flux is determined to be correct (zero position), proceed to the next step, or make adjusts as necessary and repeat (refer to table 26-1).

26.5.3.8 Raise the pilot burner to the standby position, then, using caution because it may be very hot, open the drawer and remove the HFG calibration assembly.

NOTE: It is acceptable to leave the assembly at the left end of the chamber during material testing if the HFG is protected and cooling water is flowing to prevent damage to the sensor.

26.5.4 Three-Position Check

A three-position heat-flux check is required whenever the radiant panel is replaced or whenever the HFG has been recalibrated or replaced. To ensure the panel is operating correctly, there must be a drop in observed heat flux as the distance from the zero position increases (position #2). Allow the HFG to reach steady state at each position before recording the heat flux. The distance between the centerlines of each of the three positions is 2 ± 0.0625 inches (50.8 ± 1.6 mm). As the holder is being moved, make sure to place high-temperature boards to the right of the holder to prevent heat loss. For daily testing, a heat flux check in the zero position is sufficient.

26.5.4.1 Conduct “Zero Position Calibration” (see section 26.5.2)

26.5.4.2 Conduct “System Upset Check” (see section 26.5.3)

26.5.4.3 Raise the pilot burner to the standby position, open the drawer, and move the calibration assembly to position #1. Move insulation boards to the left. Cover any gap that opened to the right side of the calibration assembly.

26.5.4.4 Close the drawer and lower the pilot burner into test position. Calculate the 5-minute heat-flux rolling average to confirm heat flux is within range for position #1 (refer to table 26-1).

26.5.4.5 Raise the pilot burner to the standby position, open the drawer, and move the calibration assembly to position #2 (refer to table 26-1). Move insulation boards to the left. Cover any gap that opened to the right side of the calibration assembly.

26.5.4.6 Close the drawer and lower the pilot burner into test position. Calculate the 5-minute heat-flux rolling average to confirm heat flux is within range for position #2.

26.6 Test Procedure

26.6.1 General Information

Once calibration is verified, testing can begin. If testing is not conducted for a period of time exceeding 30 minutes, the HFG calibration assembly must be installed and allowed to stabilize for a minimum of 5 minutes, followed by a “System Upset Check” (section 26.5.3). The heat flux must return to the zero-position range, as specified in table 26-1, during this check.

NOTE: It is extremely important that each test must be carefully observed to determine the melt, ignition and burn times accurately.

26.6.2 Test Sequence

26.6.2.1 Conduct “Zero Position Calibration” (see section 26.5.2)

26.6.2.2 Conduct “System Upset Check” (see section 26.5.3)

26.6.2.3 Stack up insulation boards inside the drawer so the top surface of the test sample will be level with the top surface of the drawer upper flange when the sample holder is sitting on top of the insulation boards. The rest of the inside of the drawer should be completely covered with insulation boards so no convective airflow can pass through.

26.6.2.4 Ignite the pilot burner and keep it in the standby position. Verify that the flame is the correct length.

26.6.2.5 Weigh the test sample.

26.6.2.6 Insert the test sample into the sample holder. Open the drawer and place the test sample and holder on the sliding platform using the sample holder alignment tool (see figures 26-8, 26-9, and 26-10). Once aligned, remove the alignment tool.

26.6.2.7 Immediately push the sliding platform into the chamber (within 3 seconds or less).

26.6.2.8 Within 1 second or less, bring the pilot burner flame into contact with the sample at the zero position, and simultaneously start the timer.

26.6.2.9 After a pilot flame impingement time of 120 seconds, quickly lift the burner flame to the standby position within 1 second or less. Allow the test to progress for an additional 120 seconds.

26.6.2.10 Open the drawer and continue to observe the test sample remaining in the sample holder. If the sample is still burning, measure the time when the burning ends, then remove the sample holder and test sample. Set sample and any remnants aside to cool. To avoid excessive heat loss, keep the drawer closed when not loading, measuring, or unloading samples.

26.6.2.11 Weigh the sample and remnants after carefully blowing off any oxidation or residue.

NOTE: This process should be completed within 1 hour of the end of the test.

26.6.2.12 When test series is complete, conduct system “Recheck” to verify posttest heat flux is within range. If not within range, previous test data are invalid (refer to table 26-1).

26.6.3 System Recheck Procedure

26.6.3.1 Install the HFG fixture at the zero position. Place a sheet of noncombustible material on top of the sliding platform adjacent to the calorimeter fixture (to the left) to prevent heat loss during calibration. All gaps within the drawer opening that could allow air to flow through must be covered.

26.6.3.2 Ensure the HFG surface is clean, properly aligned, and that cooling water is flowing. Close the sliding platform.

26.6.3.3 The pilot burner must be off and in the down position (test position).

26.6.3.4 Allow the system to stabilize for 25 minutes.

26.6.3.5 After 25 minutes, calculate the zero-position “Recheck” heat flux using the HFG millivolt signal and its calibration constant, and begin a 5-minute rolling average.

26.6.3.6 After 5 minutes (no adjustments permitted), verify heat flux is within the “Recheck” range (table 26-1).

26.6.3.7 You may continue material testing after a “Recheck,” or shut down the system and allow the apparatus to cool to ambient conditions if testing has been completed.

26.7 Report

26.7.1 Setpoint Temperature

Record the temperature set point for the radiant panel power controller.

26.7.2 Zero Position Calibration

Record the 5-minute average heat-flux value (BTU/ft²-sec or W/cm²).

26.7.3 Chamber Temperature

Report the pretest chamber temperature after calibration.

26.7.4 System Recheck

Record the 5-minute average heat-flux value (BTU/ft²*sec).

26.7.5 Material Identification

Fully identify and describe the test sample (e.g., alloy, grade, thickness).

26.7.6 Melting

Report the melting time in seconds for each sample tested.

26.7.7 Ignition Time

Report the ignition time in seconds for each sample tested.

26.7.8 Burn Time

Report the time burning began for each sample tested.

26.7.9 Self Extinguishment Time

If the sample burns, report the time for each sample to self-extinguish.

26.7.10 Notes/Comments

Report any occurrences of sparking, melting, glowing, swelling, flashing, or char.

26.7.11 Weight Loss

Calculate and record the weight percentage loss of each test sample by combining the final weight of the sample remaining in the holder and any additional remnants removed from the top of the insulation. Ensure that the remnant weight includes only metallic components, and no oxidized material or insulation board material. The combined weight of the tested sample and remnants can be subtracted from the initial weight of the sample. This value can then be divided by the initial weight, and the value multiplied by 100 to determine the percentage weight loss.

26.8 Requirements

26.8.1 Ignition Time

The time to ignition, after placement of the pilot burner flame, must not be less than **30** seconds.

26.8.2 Weight Loss

The calculated weight loss may not exceed 30%.

26.8.3 Self Extinguishment

Measuring the exact time of flame extinguishment of the test sample is difficult and subjective, given the nature of a burning magnesium alloy. The transition of the alloy from burning to self-extinguishment typically happens gradually rather than instantaneously, as is the case with most traditional cellulosic materials. For this reason, a maximum allowable time until self-extinguishment of the test sample is not required, per se. However, if new magnesium alloys become available that exhibit extended burn periods prior to self-extinguishment, but still pass the weight loss criteria, it may be necessary to incorporate a maximum time requirement for the alloy to self-extinguish.

26.8.4 A minimum of three samples must be tested. If the minimum three samples fail to meet the above requirements, it is possible to run additional tests if 80% or more of the total number of samples meet the requirements. For example, if one of the three original samples fails the test requirement, two additional passing tests can be conducted for a total of four passing tests in five opportunities ($4/5 = 80\%$).

NOTE: The additional testing is intended for materials that typically meet the test requirements but experience an unexpected failure for unknown reasons. These failures, often referred to as rogue failures, are unanticipated and cannot be explained. Additional testing should not be viewed as a technique for meeting the requirement with inferior materials.