

Chapter 11

Powerplant Hose Assemblies Test

11.1 Scope

- 11.1.1 This test method is used to determine the fire resistance of high-temperature hose assemblies used in designated fire zones to damage due to flame and vibration for showing compliance with TSO C42, C53A, and C75.
- 11.1.2 The requirements and procedures of this test method vary according to hose materials and hose assembly application.

11.2 Definitions

11.2.1 Designated Fire Zone

A designated fire zone is defined as a region of the aircraft, such as engine and auxiliary power unit compartments designated to require fire detection and extinguishing equipment, and as appropriate, the use of materials that are fire resistant or fireproof.

11.2.2 Fireproof

Per FAR Part 1, (found in Subchapter A—Definitions, Part I—Definitions and Abbreviations) “in designated fire zones means the ability of materials to withstand the heat from a severe fire of extended duration at least as well as steel in dimensions appropriate for their purpose.”

Powerplant hose assemblies are demonstrated to be fireproof by meeting the requirements of this test for a flame exposure time of 15 minutes.

11.2.3 Fire Resistant

Per FAR Part 1, (found in Subchapter A—Definitions, Part I—Definitions and Abbreviations) “with respect to fluid carrying lines, fluid system parts, wiring, air ducts, fittings, and powerplant controls means the capacity to perform the intended functions under the heat and other conditions likely to occur when there is a fire at the place concerned.”

Powerplant hose assemblies are demonstrated to be fire resistant by meeting the requirements of this test for a flame exposure time of 5 minutes.

11.2.4 Class A Hose Assembly

A class A hose assembly is defined as a hose assembly capable of withstanding exposure to this fire test procedure for 5 minutes without failure (e.g., leaking circulating oil) per TSO C53a.

11.2.5 Class B Hose Assembly

A class B hose assembly is defined as a hose assembly capable of withstanding exposure to this fire test procedure for 15 minutes without failure (e.g., leaking circulating oil) per TSO C53a.

11.2.6 Velometer

A device for measuring airflow velocity.

11.2.7 Photocell

An electronic device having output that varies in response to the intensity of incident visible light.

11.3 Apparatus

11.3.1 Test Burner

A modified gun-type conversion oil burner as described in table 11-1 will be used. The burner will be calibrated to provide a minimum average flame temperature of 2,000°F (1,100°C) and a minimum

Table 11-1. Test Burner Information

| Burner Standard Model Designation | Power Supply | Test Nozzle | Test Fuel Flow -0, +0.05 gal/hr | Test Air Pressure in Draft Tube (ref) | Modifications to Standard Burner |
|--|--------------------------------|-----------------------------------|--|---------------------------------------|---|
| Stewart Warner HPR-250 This burner is no longer available. Supplier Stewart-Warner Corp. Heating & Air Conditioning Lebanon, Indiana 46052 | 1/4 HP/115V/ 60Hz/single ph | 2.25 gal/hr 80-degree angle | 2 gal/hr (95-psig pump press ref) | 0.14 in H ₂ O | <ol style="list-style-type: none"> Air tube diameter reduced to 2.5 inches (63.5 mm), starting 1.5 inches (38 mm) forward of nozzle tip. Added four 3/4- by 1/16-inch (19- by 1.59-mm) stainless steel fuel deflectors mounted on the reducing cone at 3, 6, 9, and 12 o'clock. The deflector edges were 3.4 inches (19 mm) off center line (CL) and 3.4 inches (19 mm) forward of fuel nozzle up. Added static air pressure port 1 inch (25.4 mm) forward of the burner tube mounting flange. Added a 12.5 inch (317.5 mm) burner extension so that the wide end is 10 inches (254 mm) beyond the end of the air tube. |
| Stewart Warner FR-600 This burner is no longer available. Supplier Stewart-Warner Corp. Heating & Air Conditioning Lebanon, Indiana 46052 | 1/3 HP/115V/ 60Hz/single ph | Same as above | 2 gal/hr (100-psig pump press ref) | 0.01 in H ₂ O | <ol style="list-style-type: none"> Air tube diameter reduced to 2.5 inches (63.5 mm), starting 1.5 inches (38 mm) forward of nozzle tip. Added four 3/4- by 1/16-inch (19- by 1.59-mm) stainless steel fuel deflectors mounted on the reducing cone at 3, 6, 9, and 12 o'clock. The deflector edges were 3.4 inches (19 mm) off CL and 3.4 inches (19 mm) forward of fuel nozzle up. Added static air pressure port 1 inch (25.4 mm) forward of the burner tube mounting flange. Added a 12.5-inch (317.5-mm) burner extension so that the wide end is 10 inches (254 mm) beyond the end of the air tube. |
| Lennox OB-32 (This is now obsolete and cannot be purchased.) | | 2.25 gal/hr 80-degree angle | 2 gal/hr (80-psig pump press ref) | 0.17 in H ₂ O | <ol style="list-style-type: none"> Add a 12.5-inch (317.5 mm) burner extension. |

Table 11-1. Test Burner Information—(Continued)

| Burner Standard Model Designation | Power Supply | Test Nozzle | Test Fuel Flow | Test Air Pressure in Draft Tube (ref) | Modifications to Standard Burner |
|--|--|----------------------|---|---------------------------------------|--|
| <p>Carlin 200CRD</p> <p>This burner is not available with modifications.</p> <p>Supplier Carlin Co. 912 Silas Dean Hwy Wethersfield, Conn. 06109</p> | <p>1/4 HP/115V/ 60Hz/single ph</p> | <p>Same as above</p> | <p>2 gal/hr (97-lb/in² pump press ref)</p> | <p>0.37 in H₂O</p> | <ol style="list-style-type: none"> 1. Disassemble the burner air tube assembly and remove the throttle ring and the retention ring. 2. Remove the existing fuel nozzle and install an 80-degree, 2.25-gal/hr nozzle. After reassembly, adjust the OD delivery rate to 2.01 gal/hr at 97 lb/in² gauge. 3. Using 1/16 inch stainless steel material, manufacture and install three deflectors. 4. Manufacture a flat-disk plate to match the inside diameter of the burner air tube and randomly punch 10 1/2-inch holes as shown. The main purpose of this disk is to center the oil delivery tube. Locate and punch holes for the ignitors and the oil delivery tube. A pie-shaped segment was cut out for ease of installation and the split-baffle mounting bracket was secured to the oil delivery tube with a small hose clamp. Position this flat-disk plate 4 inches aft of the fuel nozzle. 5. Manufacture and install a reducing cone. The outside diameter of this cone should match the inside diameter of the oil burner air tube. This cone is secured in place with small Allen or socket head screws. 6. Install the static pressure port 1 inch forward of the air tube mounting flange and adjust the air pressure in the air tube to approximately 0.37 inch of H₂O during operation. 7. Manufacture a 12 1/2-inch burner air tube extension and install this extension so that the wide end is 10 inches beyond the end of the burner air tube. |

Table 11-1. Test Burner Information—(Continued)

| Burner Standard Model Designation | Power Supply | Test Nozzle | Test Fuel Flow -0, +0.05 gal/hr | Test Air Pressure in Draft Tube (ref) | Modifications to Standard Burner |
|---|--------------|-------------|------------------------------------|---------------------------------------|---|
| Park DPL 3400 Supplier Park Manufacturing Company New York and Absecon Blvd. Atlantic City, New Jersey 08401 | | | | | This burner will be built to the FAA's specifications upon request. |

heat input of 4,500 Btu/hr to the Btu heat transfer device described in section 11.3.3.2, or 9.3 Btu/ft²-sec (10.6 W/cm²) as measured by a calorimeter described in section 11.3.3.1.

11.3.1.1 Burner Extension

A stainless steel funnel extension, fabricated in accordance with figure 11-1, will be used. The funnel will have an oblong exit 6 inches (152 mm) high by 11 inches (279 mm) wide. The funnel will be installed on the burner with the air tube shown in figure 11-2.

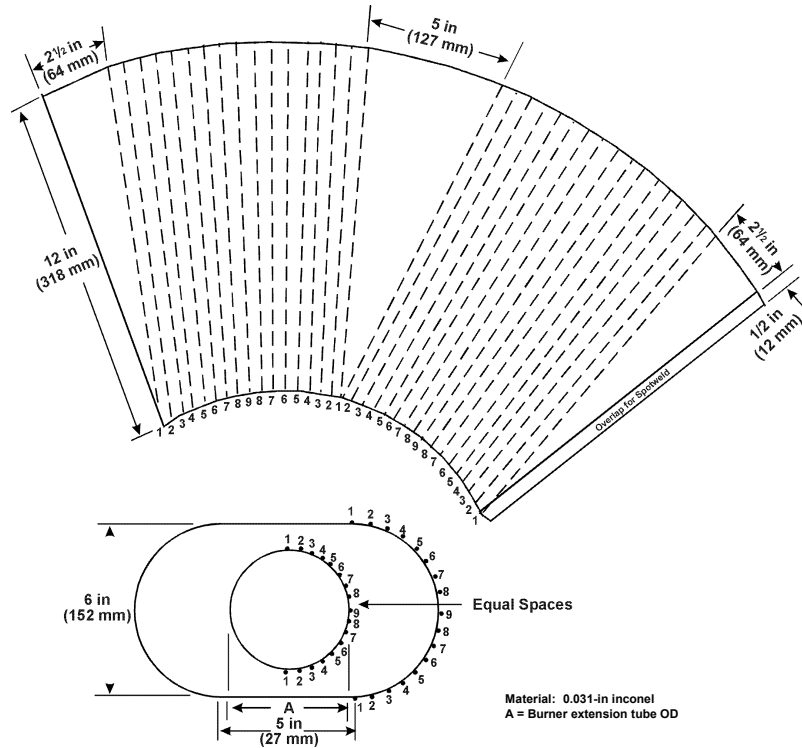

Figure 11-1. Burner Extension Funnel

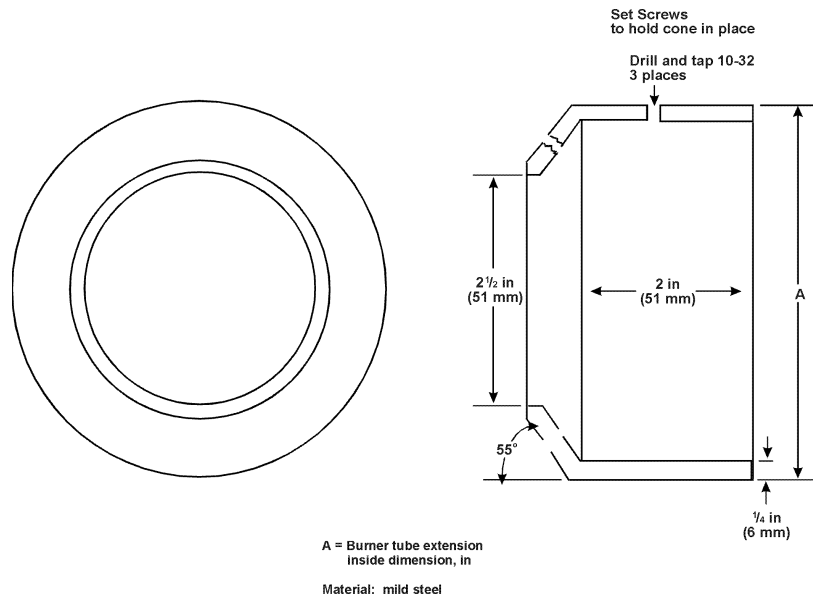

Figure 11-2. Air Tube Reducing Cone

11.3.1.2 Burner Fuel

Society of Automotive Engineers (SAE) No. 2 diesel, kerosene, or equivalent will be used for burner fuel.

11.3.2 Thermocouples

A thermocouple rake containing at least five American National Standard Institute (ANSI) 22-gauge Chromel-Alumel (Type K) thermocouple sheathed in 1/16-inch (1.6-mm) -thick stainless steel or inconel tubes, or equivalent, will be provided. The thermocouples will be aligned in a row 1 ± 0.1 inch (25 ± 3 mm) apart.

11.3.3 Heat Flux Measuring Device

One of the following devices will be used to measure the heat flux density of the flame.

11.3.3.1 Calorimeter

A water-cooled calorimeter capable of measuring heat flux densities up to $15 \text{ Btu/ft}^2\text{-sec}$ (17 W/cm^2) may be provided for burner calibration. A Hy-Cal model 1300A total heat flux density calorimeter available from Hy-Cal Engineering, Santa Fe Springs, California, or equivalent has been found suitable.

11.3.3.2 Btu Heat Transfer Device

Figures 11-4 to 11-10 show fabrication details of an acceptable copper tube device used to measure heat flux density. The mercury thermometers will be positioned in the mounting tubes so that the bottom of the bulb is within 1/16 inch (1.6 mm) of the bottom of the passage in the heat transfer tube (see figures 11-7 and 11-8).

11.3.3.2.1 Thermometers

Two glass scientific thermometers calibrated in 0.05°C (0.1°F) increments, immersible thermocouples, or equivalent will be provided for the heat transfer tube assembly.

11.3.4 Test Setup

A steel table measuring 60 inches (1,524 mm) wide, 28 inches (711 mm) deep, and 32 inches (813 mm) high has been found acceptable. The vibrating mechanism and hood, described below, may be mounted on this table. See figure 11-1 for an acceptable test setup.

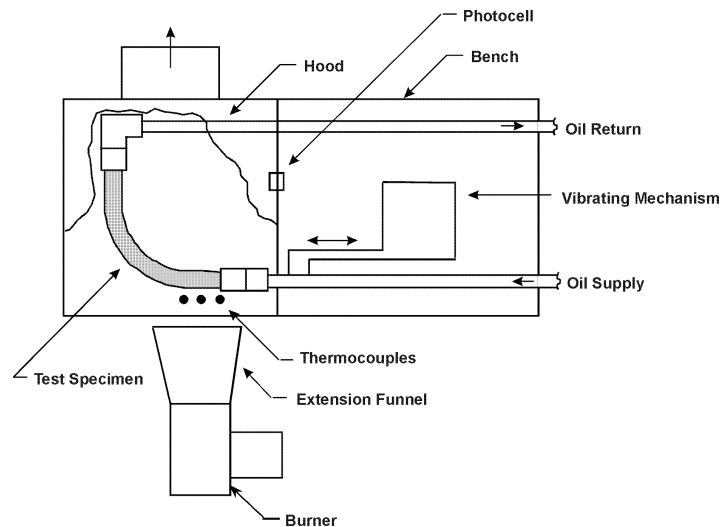

Figure 11-3. Hose Assemblies Test Setup

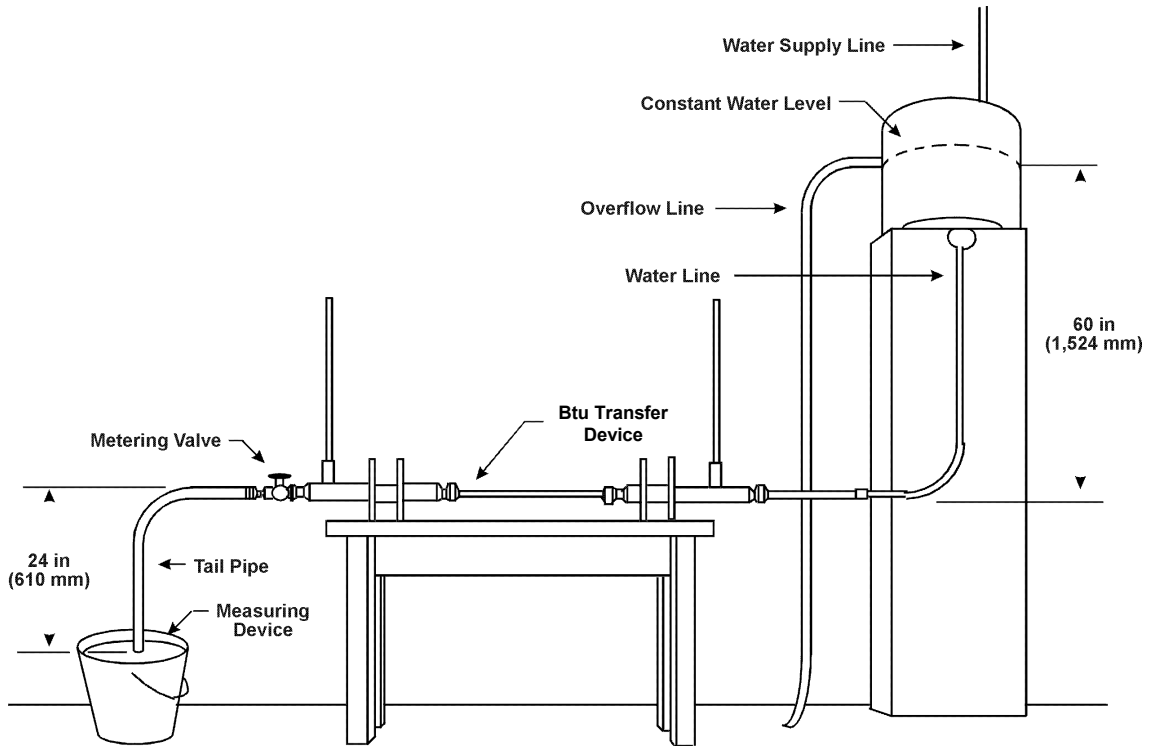

Figure 11-4. Burner Calibration Standardization Apparatus

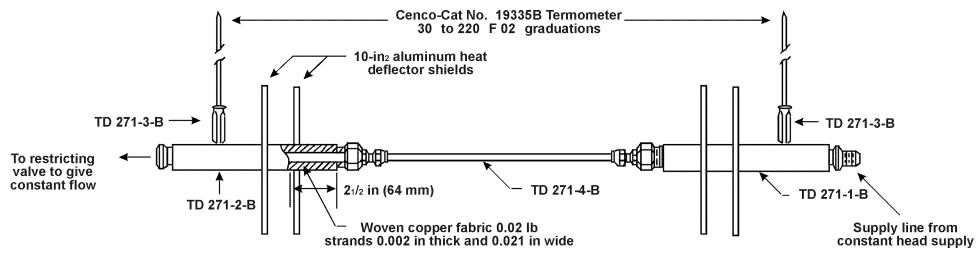

Figure 11-5. Btu Heat Transfer Device

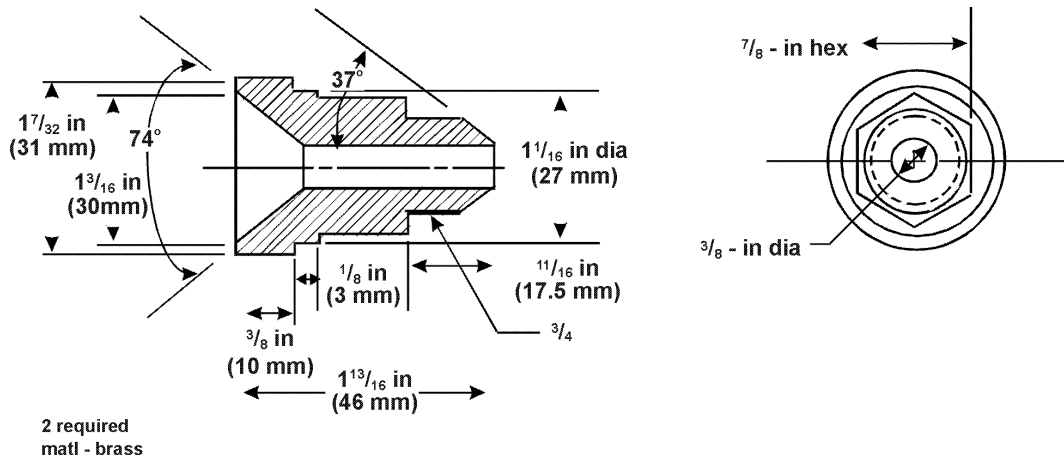

Figure 11-6. Btu Heat Transfer Device—Reducer

Material
 (Alternate material may be used provided thermal conductance is equivalent)
 1 7/16 -in OD x 1 3/16 -in ID x 12 in

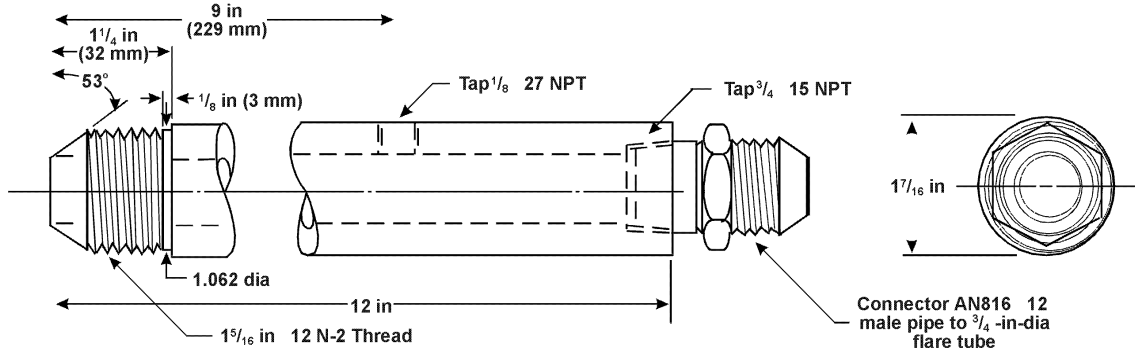

Figure 11-7. Btu Heat Transfer Device—Inlet Tube

Material—Transit Asbestos-Based Tubing
 (Alternate material may be used provided thermal conductance is equivalent)
 1 7/16 -in OD x 1 3/16 -in ID x 12 in

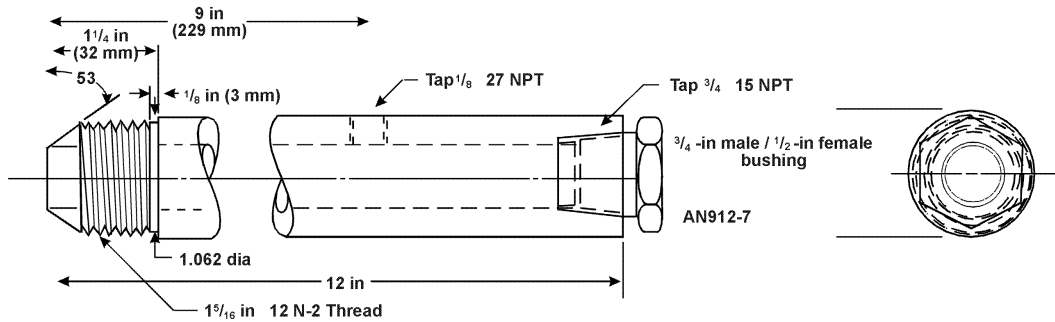

Figure 11-8. Btu Heat Transfer Device—Outlet Tube

Two required
Material: brass, 9/16 -in hex x 3 3/4 in

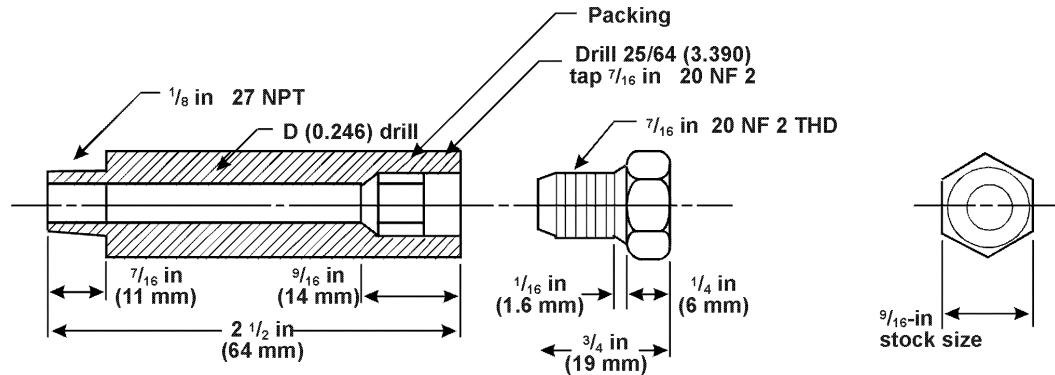

Figure 11-9. Btu Heat Transfer Device—Thermometer Mounting

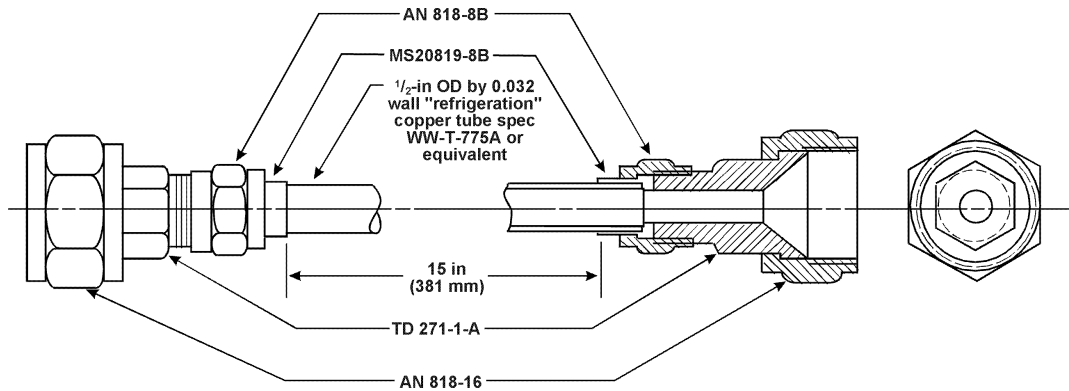

Figure 11-10. Btu Heat Transfer Device—Test Specimen

11.3.4.1 Vibration Source

A means will be provided to vibrate the hose assembly as shown in figure 11-8 at 33 Hz with a total displacement of a least 1/8 inch (3.2 mm), i.e., with an amplitude of at least 1/16 inch (1.6 mm).

11.3.4.2 Hood

A hood measuring 25 inches (635 mm) wide and 25 inches (635 mm) high has been found acceptable. The hood may be placed on the bench near the vibration source so that the vibrating fitting for the hose attachment is located 7 inches (178 mm) behind the open front of the hood.

11.3.4.2.1 Fan

The hood will have a fan installed on the rear to draw air through it at a velocity of 400 ft/min (203 cm/s), as measured by a velometer located at the position occupied by the hose assembly specimen during the test.

11.3.4.2.2 Photocell

The hood may contain a photocell to detect a flareup resulting from burning oil due to a hose failure.

11.3.4.3 Automatic Shutdown System

If a flareup of burning oil escaping from a failed hose assembly is detected, an automatic shutdown system may be provided to terminate the test by turning off the burner, vibrating mechanism, hood fan, and oil flow.

11.3.4.4 Temperature Measuring and Recording Equipment

A temperature sensing system will be provided that includes a sufficient number of thermocouples to ensure that the specified temperature exists along the entire end fitting and along the hose for a distance of not less than 5 inches (127 mm). The system will include a recorder to monitor the flame temperature throughout the fire test duration.

11.3.5 Oil Circulator and Heater

A device consisting of an oil tank with a temperature-controlled immersion heater and an electric oil pump will be provided if the hose assembly being tested must have oil pumped through the hose(s) during the test. The plumbing will include appropriate flow indicators, pressure gauges, control and selector valves, and pressure relief valves.

11.3.5.1 Oil

SAE No. 20 oil, in accordance with Military Specification MIL-L-2104C or equivalent, will be provided and used in the oil circulator and heater to pump through the hose assembly test specimen during the test.

11.4 Test Specimens

- 11.4.1 Prepare three specimens, 24 inches (610 mm) long, for the test.
- 11.4.2 The configuration of the hose test specimens will be as used in service. A firesleeve may be added to the hose assembly, if needed, to enable the test specimens to withstand the fire test duration specified.

11.5 Calibration

- 11.5.1 Place the thermocouple rake on the test stand at a distance 4 inches (102 mm) above the centerline of the burner extension. Connect the thermocouples to a stripchart recorder.
- 11.5.2 Light the burner, allow a 3-minute warmup, and move the burner into test position.
- 11.5.3 Begin monitoring the temperatures indicated by the thermocouples after 3 minutes. Make adjustments as necessary to either the gas flow or the airflow to the burner in order to achieve a minimum average thermocouple reading of 2,000°F (1,100°C).
- 11.5.4 Turn the burner off, move it out of test position, and remove the thermocouple rake.
- 11.5.5 Replace the thermocouple rake with the heat flux measuring device. Follow section 11.5.5.1 if using a water-cooled calorimeter for measuring heat flux. Follow section 11.5.5.2 if using a Btu heat transfer device for this purpose.
 - 11.5.5.1 If using the water-cooled calorimeter described in section 11.3.3.1, place the calorimeter at the same distance as the thermocouple rake centered over the burner exit.
 - 11.5.5.1.1 Light the burner, allow a 2-minute warmup, and move the burner into test position.
 - 11.5.5.1.2 Measure the heat flux density continuously or at intervals no greater than 10 seconds. If the heat flux density is not at least 9.3 Btu/ft²-sec (10.6 W/cm²), readjust the burner to achieve the proper heat flux. If burner adjustments are necessary, remove the heat flux measuring device and repeat sections 11.5.1 through 11.5.5.1.2.
 - 11.5.5.2 If using the Btu heat transfer device described in section 11.3.3.2, ensure the external surface of the copper tubing on the Btu heat transfer device is clean prior to measuring heat flux. Use fine steel wool to clean the copper tubing. Inspect the tubing bore for corrosion and/or scale accumulation and remove before each test. A .45-caliber pistol cleaning brush, or equivalent, with an extension has been found suitable for this purpose.
 - 11.5.5.2.1 The calibration setup is shown in figure 11-3. Provide a 5-foot (1.5 m) constant head of water above the heat transfer device and a 2-foot (0.61 m) drop to the end of the tailpipe for adjustment of the water flow rate. Use a 1 gallon (3.8 L) measuring container (a container and a weighing scale are also acceptable). Adjust the water flow rate to 500 lb/hr (227 kg/hr) or 1 gal/min (3.8 L/min). Supply water at a temperature of 50 to 70°F (10 to 21°C).
 - 11.5.5.2.2 Start the water flowing through the Btu heat transfer device. Center the heat transfer tube in the flame at the same location that a hose assembly would be placed for testing. Allow a 2-minute warmup period to stabilize flame conditions before temperature measurements from the mercury thermometers are recorded.

- 11.5.5.2.3 After the warmup period, record the inlet and outlet temperatures every 30 seconds for a 3-minute period. Determine the rate of Btu increase of the water as follows:

$$\begin{aligned} \text{Heat transfer} &= 146 \times (T_o - T_i) \text{ watts (for Celsius)} \\ &= 500 \times (T_o - T_i) \text{ Btu/hr (for Fahrenheit)} \end{aligned}$$

where: T_o = temperature ($^{\circ}\text{C}$ or $^{\circ}\text{F}$) at outlet

T_i = temperature ($^{\circ}\text{C}$ or $^{\circ}\text{F}$) at inlet

- 11.5.5.2.4 The heat rate output, as determined by the equation shown in section 11.5.5.2.3, will be a minimum of 4,500 Btu's per hour. If the heat output from the burner is not above this minimum, make adjustments to the burner and repeat sections 11.5.1 through 11.5.5.2 until the burner is within tolerance.

11.6 Procedure

11.6.1 Specimen Mounting

Mount the hose assembly in the test setup to include at least one full 90-degree bend so that the pressure existing inside the hose will exert an axial force on the hose end fitting. Locate the hose assembly 4 inches (102 mm) beyond the burner barrel extension so that the entire hose assembly end fitting and at least a minimum 5 inches (127 mm) of the hose is exposed to the flame. Install the entire hose assembly inside the hood unless limited by the physical characteristics of the hose such as minimum bend radius (see figure 11-1).

- 11.6.2 Preheat the oil in the oil tank to $200^{\circ} \pm 10^{\circ}\text{F}$ ($93^{\circ} \pm 6^{\circ}\text{C}$). Start the oil circulating pump and circulate the oil through the test hose assembly at a flow rate and pressure as specified by hose type, size, and application. Pressures and flow rates are as shown in table 11-2.

Table 11-2. Circulating Oil Pressure and Flow Rate

| Hose Type | Circulating Oil | | |
|-----------|-----------------|-----------------------------|---------------------------------|
| | Pressure | Flow Rate | |
| | | GPM | L/min |
| 1a | System Working | $5 \times \text{ID (in)}^2$ | $0.03 \times \text{ID (mm)}^2$ |
| 1b | System Working | $1 \times \text{ID (in)}^2$ | $0.006 \times \text{ID (mm)}^2$ |
| 11a | System Working | $5 \times \text{ID (in)}^2$ | $0.03 \times \text{ID (mm)}^2$ |
| 11b | System Working | $1 \times \text{ID (in)}^2$ | $0.006 \times \text{ID (mm)}^2$ |

- 11.6.3 Start the vibrating mechanism and observe the movement of the hose. Ensure that no whipping of the hose occurs.
- 11.6.4 Start the hood air fan and begin monitoring the thermocouple recorder.
- 11.6.5 Start the burner. Periodically observe the recorded temperature to ensure that the required minimum flame temperature of $2,000^{\circ}\text{F}$ ($1,093^{\circ}\text{C}$) is maintained.
- 11.6.6 If a flareup of burning oil occurs due to a hose failure, terminate the test.
- 11.6.7 After the required test duration has been reached (i.e., 5 minutes for class A hose assemblies and 15 minutes for class B hose assemblies), terminate the test.
- 11.6.7.1 Stop the burner.
- 11.6.7.2 Relieve the oil pressure in the hose assembly.
- 11.6.7.3 Turn off the temperature recorder.

11.7 Report

- 11.7.1 Fully identify the hose configuration, including the assembly and fittings, and the class for which it is being tested.
- 11.7.2 Report if there were any flareups of leaking oil and any other pertinent observations.
- 11.7.3 Report whether the hose configuration met the requirements of class A or class B assemblies.

11.8 Requirements

11.8.1 Class A Hose Assembly

A class A assembly will withstand the test procedure in section 6 for at least 5 minutes without leaking circulating oil.

11.8.2 Class B Hose Assembly

A class B hose assembly will withstand the test procedure described in section 6 for at least 5 minutes without leaking circulating oil.

Chapter 11 Supplement

This supplement contains advisory material pertinent to referenced paragraphs.

11.2.6 A velometer manufactured by Alnor Instrument Company, 7555 North Linder Avenue, Skokie, Illinois 60077-3822, catalog number 01518, has been found satisfactory.

11.3.3.2 A satisfactory version of the woven copper fabric shown in figure 11-5 is manufactured by Metal Textile Corporation, Roselle, New Jersey.

11.3.4.4 Permanent installation of temperature measuring thermocouples and continuous recorder has been added for better control of the flame temperature during calibration and test.

11.4.2 If a firesleeve is required to be added for a hose type to pass the test, a firesleeve must be fitted to that hose type before it can be used in designated fire zones on an airplane.

11.6.2 Flow rate values given in table 11-2 were derived from the most recent TSO C53. Flow rates used for the test will be minimum flow rates given for the actual installation, if known.