

Chapter 8 Oil Burner Test for Cargo Liners

8.1 Scope

8.1.1 Applicability

This test method evaluates the flame penetration resistance capabilities of aircraft cargo compartment lining materials utilizing a high-intensity open flame to show compliance to the requirements of FAR 25.855.

8.2 Definitions

8.2.1 Burnthrough

Burnthrough is defined as flame penetration of the test sample or the development of a visible breach, opening, gap, fissure, or any void through which a flame penetrates during the test. The development of any such void that allows flame passage during the test period shall be cause for failure.

8.2.2 Sample Set

A sample set consists of three or more replicates of a ceiling and sidewall cargo liner panel installation.

8.3 Apparatus

8.3.1 Test Sample Frame

The test sample frame is shown in figures 8-1 through 8-3.

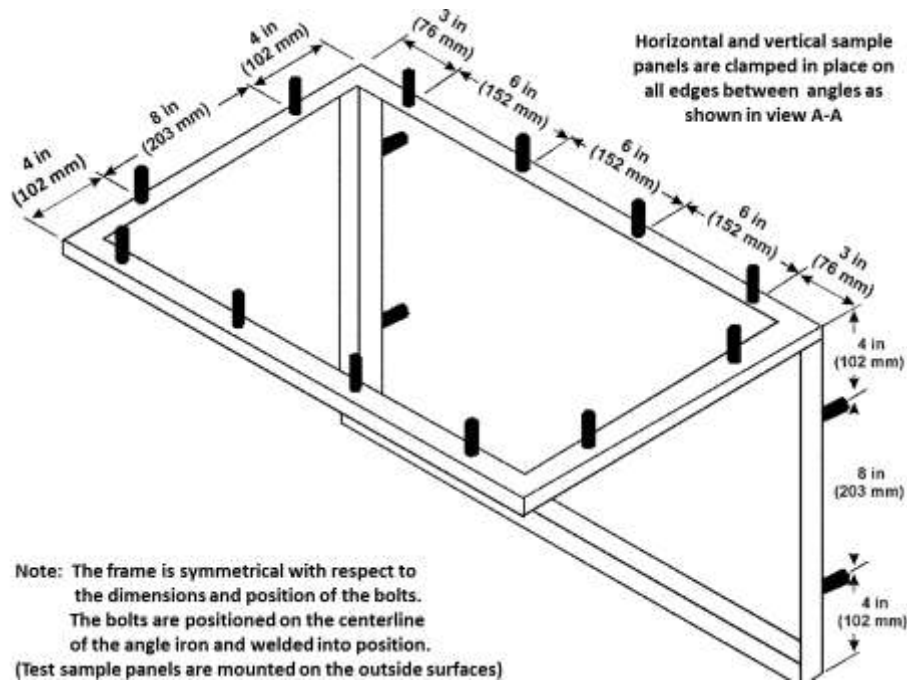
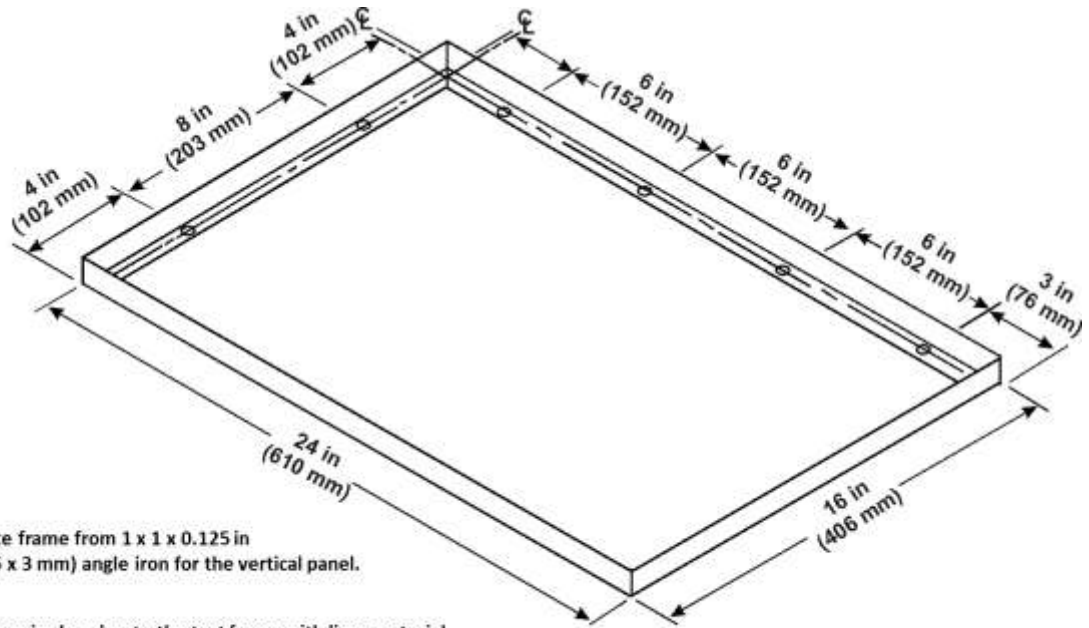

Figure 8-1. Cargo Liner Test Sample Frame



Note: Fabricate frame from 1 x 1 x 0.125 in (25 x 25 x 3 mm) angle iron for the vertical panel.

(Retaining frame is placed onto the test frame with liner material placed between test frame and retaining frame. Bolt frames together to prevent liner sample panel from slipping.)

Figure 8-2. Cargo Liner Test Vertical Sample Panel Retaining Frame

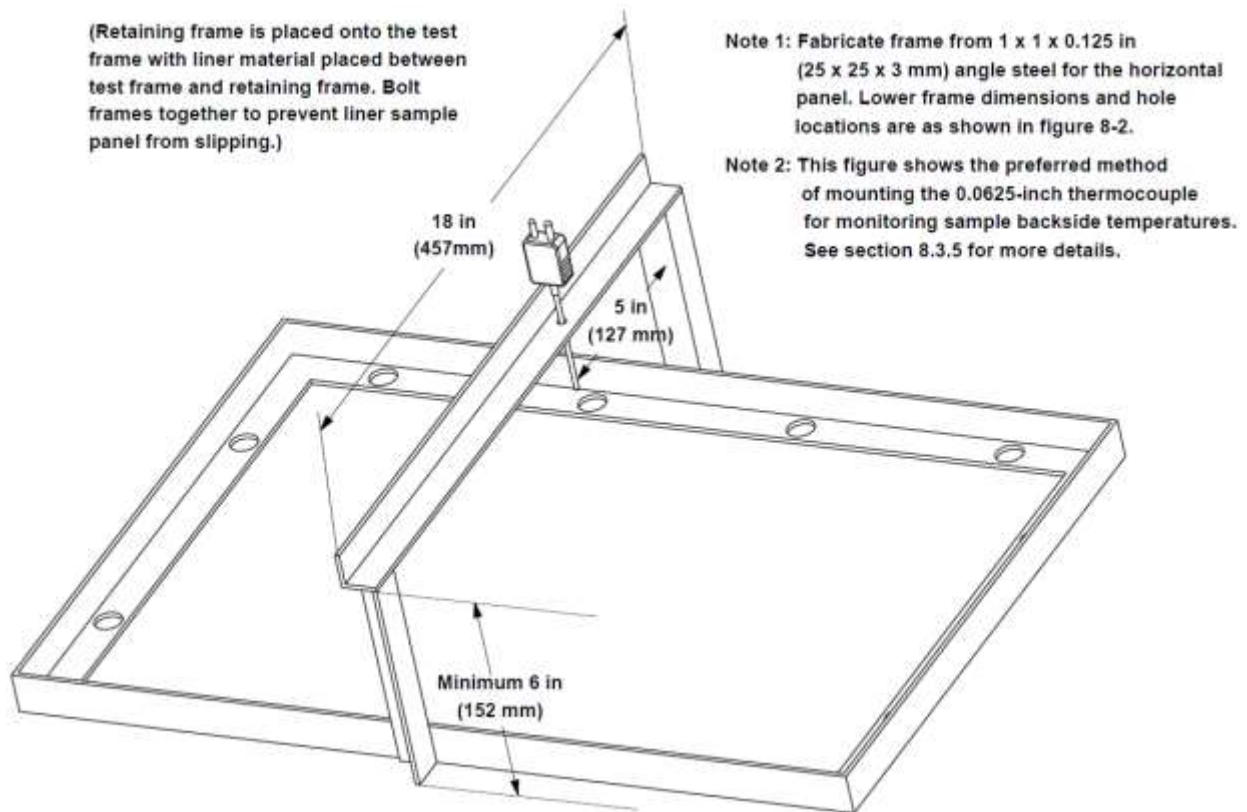

(Retaining frame is placed onto the test frame with liner material placed between test frame and retaining frame. Bolt frames together to prevent liner sample panel from slipping.)

Note 1: Fabricate frame from 1 x 1 x 0.125 in (25 x 25 x 3 mm) angle steel for the horizontal panel. Lower frame dimensions and hole locations are as shown in figure 8-2.

Note 2: This figure shows the preferred method of mounting the 0.0625-inch thermocouple for monitoring sample backside temperatures. See section 8.3.5 for more details.

Figure 8-3. Cargo Liner Test Horizontal Sample Panel Retaining Frame

8.3.2 Test Burner

The burner should be mounted on a swiveling device capable of allowing it to be directed away from the test sample during warmup as shown in figure 8.4. The burner will be a modified gun type, such as Park Model DPL 3400, Lennox Model OB-32, or Carlin Model 200 CRD. Flame characteristics can be enhanced by the optional use of a static disk or tabs as described in section 8.6.7. Major deviations, such as a different burner type, should have thorough comparison testing. Temperature and heat flux measurements, as well as test results, must correspond to those produced by an FAA approved burner.

NOTE 1: The basic burner and the use of tabs are described in FAA Powerplant Engineering Report No. 3A, "Standard Fire Test Apparatus and Procedure for Flexible Hose Assemblies," dated March 1978, and Report No. DOT/FAA/RD/76/213, "Re-evaluation of Burner Characteristics for Fire Resistant Tests," dated January 1977. The test settings specified in this specification, however, differ from those specified in the above reports.

NOTE 2: If a sonic type burner is to be used, see Chapter 8 Supplement for all test burner information.

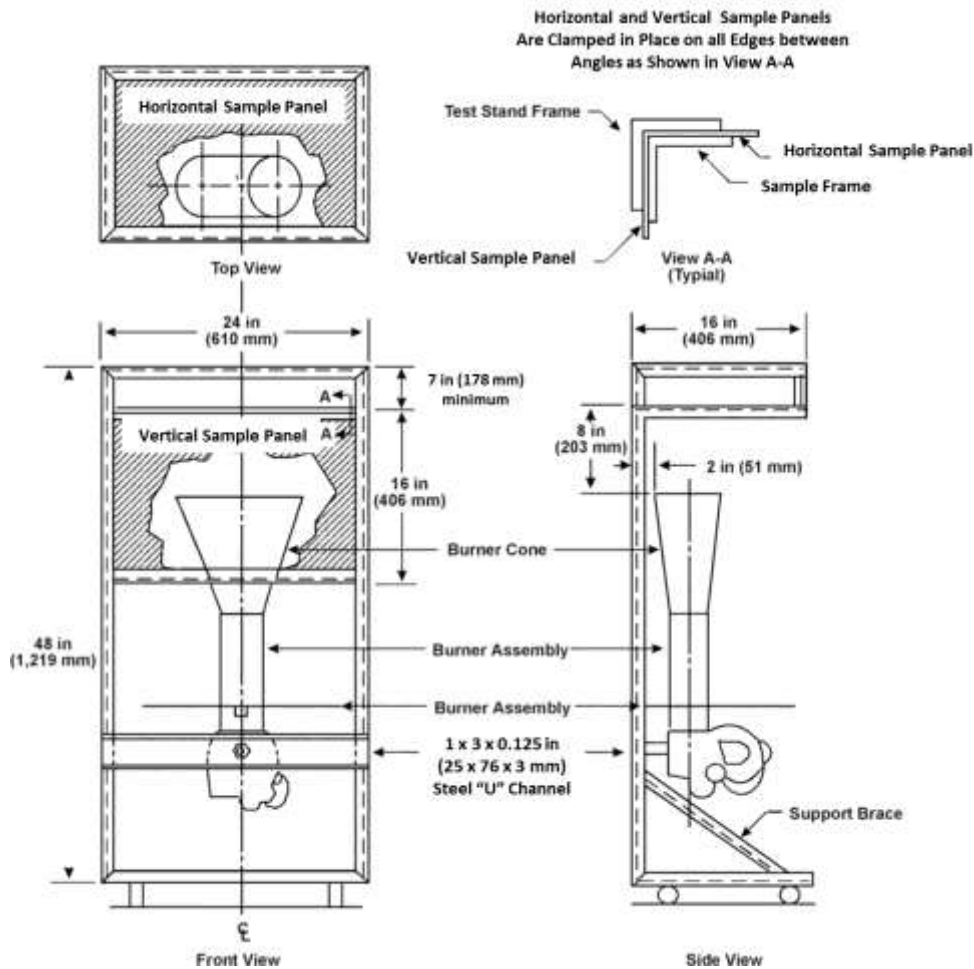

Figure 8-4. Test Apparatus for Horizontal and Vertical Mounting for Cargo Liner Oil Burner Testing

8.3.2.1 Fuel Nozzle

A nozzle will be provided to maintain the fuel pressure to yield a nominal 2 ± 0.1 gal/hr (7.57 L/hr ± 0.38 L/hr) fuel flow.

NOTE: A Monarch 80°AR or 80°R nozzle nominally rated at 2.25 gal/hr (8.52 L/hr) at 100 lb/in² (0.71 MPa) and operated at 85 lb/in² (0.6 MPa) gauge, has been found to deliver 2 gal/hr (7.57 L/hr) and produce a proper spray pattern. A Monarch 80° Constant Capacity (CC) nozzle, nominally rated at 2 gal/hr at 100 lb/in² and operated between 95 and 105 lb/in² gauge is also acceptable. Minor deviations to the fuel nozzle spray angle, fuel pressure, or other similar parameters are acceptable if the fuel flow rate, temperatures, and heat flux measurements conform to the requirements of sections 8.5 and 8.6.

8.3.2.2 Fuel Pressure Regulator

A fuel pressure regulator adjusted to deliver 2 gal/hr ± 0.1 gal/hr (7.57 ± 0.38 L/hr) will be provided.

NOTE: For example, an operating fuel pressure of 85 ± 4 psig (0.57 ± 0.03 MPa) for a 2.25 gal/hr (8.52 L/hr) 80° spray angle nozzle has been found satisfactory but is not required.

8.3.2.3 Fuel

Either number 2 Grade kerosene or American Society for Testing and Materials (ASTM) D2 fuel (number 2 Grade fuel oil) will be used.

NOTE: Number 2 Grade diesel fuel, Jet A, or the international equivalent is the recommended fuel because it has been found to produce satisfactory results if the flow rate and inlet airflow conform to the requirements of sections 8.5 and 8.6 of this handbook.

8.3.2.4 Burner Cone

A 12 ± 0.125 -inch (305 ± 3 -mm) burner cone extension will be installed at the end of the draft tube. The cone will be made of 310 stainless steel or a similar type of noncorrosive high-temperature metal and will have a thickness of 0.050 ± 0.015 inch (1.27 ± 0.381 mm). The opening of the cone will be 6 ± 0.125 inches (152 ± 3 mm) high and 11 ± 0.125 inches (280 ± 3 mm) wide (figures 8-5a and 8-5b).

NOTE 1: It is critical to periodically check the cone exit plane dimensions to ensure they remain within specified tolerances. It is recommended this be performed at the beginning and end of each day the burner is operated.

NOTE 2: Park type burner cones are 18 gauge 310 stainless steel or similar alloy while sonic type burners are 16 gauge 310 stainless steel.

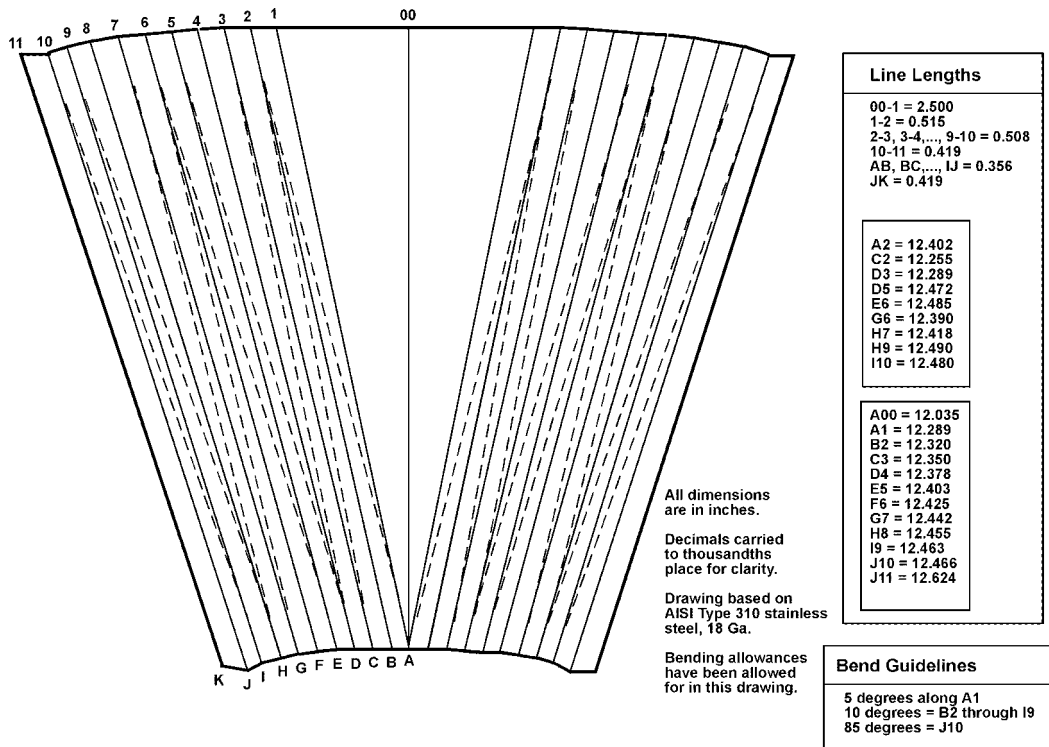

Figure 8-5a. Burner Cone Layout and Bending Pattern

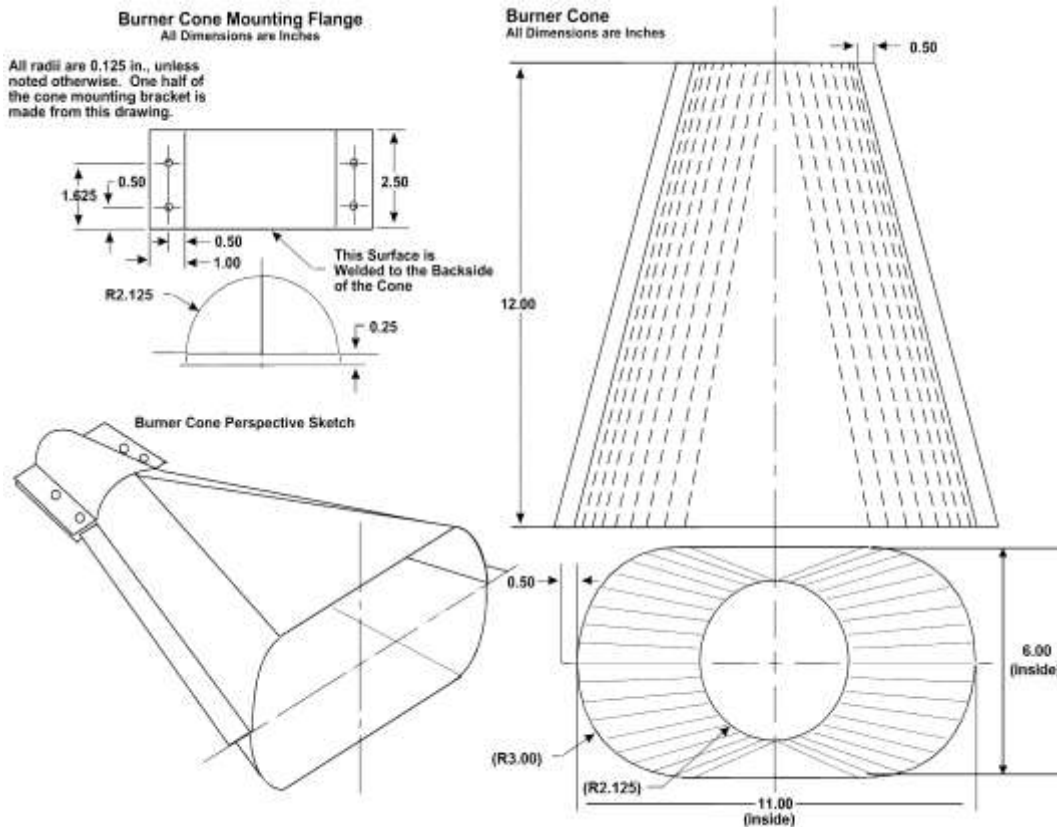

Figure 8-5b. Burner Cone Details

8.3.3 Calorimeter

The calorimeter will be a total heat flux density, foil type Gardon Gauge of an appropriate range, such as 0-15 BTU/ft²-sec (0-17 W/cm²), accurate to ± 3 percent of the indicated reading.

8.3.3.1 Calorimeter Mounting

The calorimeter will be mounted in a 6 by 12 ± 0.125 -inch (152 by 305 ± 3 -mm) by 0.75-inch (19-mm) -thick insulating block that is attached to a steel angle bracket for placement in the test stand 8 ± 0.125 inches (203 ± 3 mm) from the burner cone exit plane and directly above the center of the burner cone exit plane during burner calibration (figure 8-6). The insulating block will be monitored for deterioration and the mounting shimmed as necessary to ensure that the calorimeter face is parallel to the exit plane of the test burner cone.

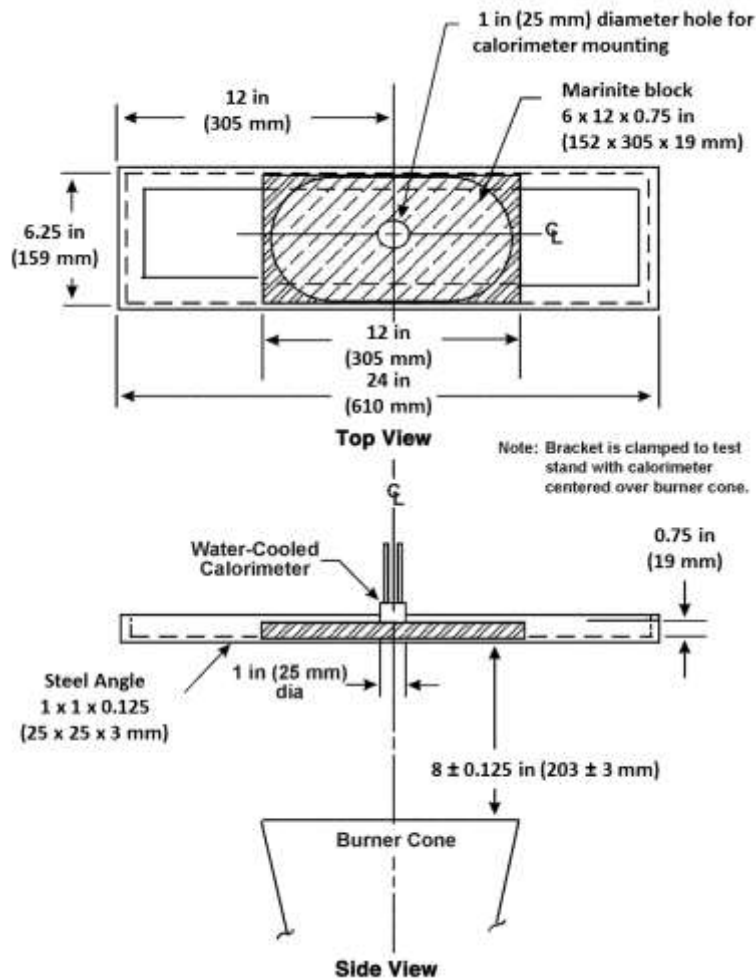

Figure 8-6. Top and Side Views of Calorimeter Bracket

8.3.4 Calibration Thermocouples

The seven thermocouples to be used for calibration will be 0.0625-inch (1.6-mm) insulation packed, metal sheathed, type K (Chromel-Alumel), grounded junction thermocouples with a nominal 30 AWG size conductor. Thermocouples purchased with a certificate of calibration may provide more accurate readings but are not required. The seven thermocouples must be attached to a steel angle bracket to form a thermocouple rake for placement in the test stand 8 ± 0.125 inches (203 ± 3 mm) from the burner cone exit plane and directly above the horizontal centerline of the burner cone exit plane during burner calibration (figure 8-7).

NOTE: The thermocouples are subjected to high temperature durations during calibration. Because of this type of cycling, the thermocouples may degrade with time. Small but continuing decreases or extreme variations in temperature or “no” temperature reading at all are signs that the thermocouple or thermocouples are degrading or open circuits have occurred. In this case, the thermocouple or thermocouples should be replaced in order to maintain accuracy in calibrating the burner. Although not required, it is recommended that a record be kept for the amount of time the thermocouples are exposed to the oil burner’s flame.

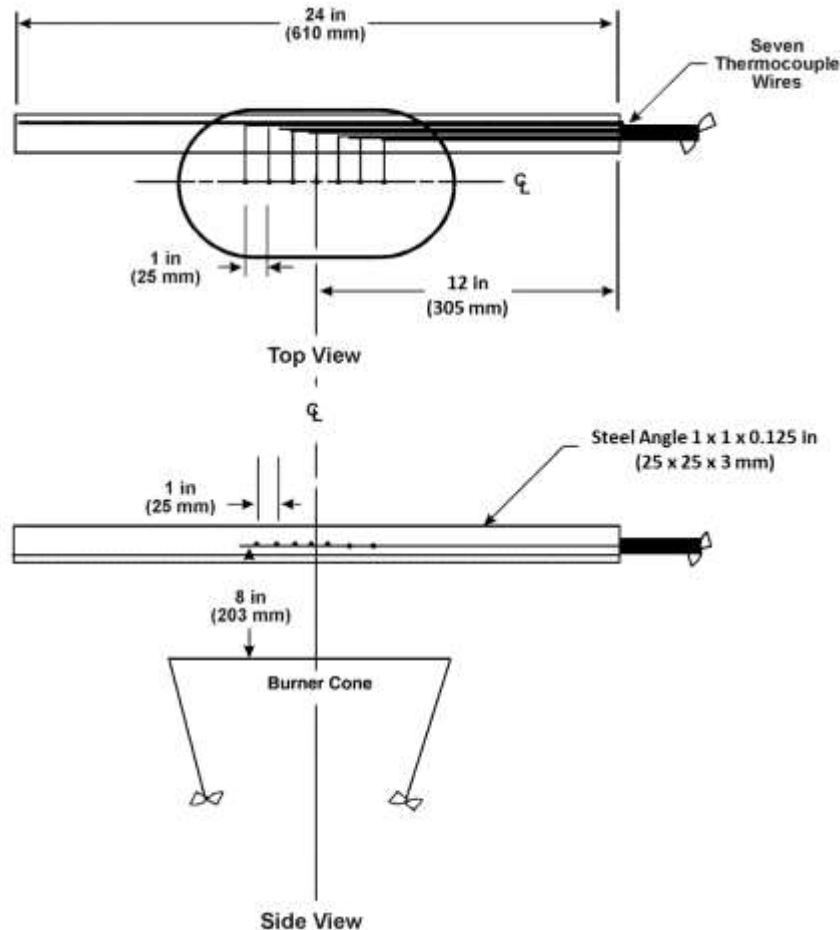

Figure 8-7. Top and Side View of Thermocouple Rake Bracket

8.3.5 Sample Backside Temperature Thermocouple

A thermocouple will be used to monitor the temperature above the ceiling (horizontal) panel during cargo liner sample testing (figure 8-3). The thermocouple must be 0.0625-inch (1.6-mm) diameter, **insulation** packed, 310 stainless steel sheathed, type K (Chromel-Alumel), grounded-junction with a nominal 30 American Wire Gauge (AWG) size conductor. The thermocouple tip should be a minimum of 2 inches (51 mm) away from any hardware used to mount the thermocouple in the test position.

NOTE: Figure 8-3 shows the preferred method of mounting the sample backside temperature thermocouple during sample testing. However, the center thermocouple (thermocouple number 4) on the 0.0625-inch thermocouple calibration rake may be used as an alternative temperature measurement method of the sample backside. The 0.125-inch thermocouples for use with the sonic type burner flame validation procedure are not to be used for monitoring sample backside temperature during sample testing.

8.3.6 Instrumentation and Supporting Equipment

8.3.6.1 Data Acquisition

A calibrated recording device or a computerized data acquisition system with an appropriate range will be provided to measure and record the outputs of the calorimeter and/or the thermocouples.

8.3.6.2 Timing Device

A stopwatch or other device accurate to within ± 1 second per 8 hours (± 3 seconds/day) will be provided to measure the time of application of the burner flame, the material flaming time, and the burnthrough time.

8.3.6.3 Intake Air Anemometer

A vane-type air velocity sensing unit will be used to monitor the flow of air at the intake of the oil burner. The intake will be completely sealed except for an opening for the air velocity sensor where the intake will be centered and mounted (figure 8-8).

NOTE: The Omega microprocessor-based portable air velocity kit, model HH-30 (later updated to model HHF142B), is a recommended unit. The kit includes a vane-type air velocity sensor, hand-held digital readout displaying air velocity, extension rods, and a 9-volt lithium battery. Since the unit monitors air velocity in FPM or MPS ± 1 percent reading accuracy, necessary conversions must be made to attain airflow values. To do this, the area of the opening of the air sensor must be measured. Once the area is found, install the air velocity sensor at the oil burner inlet (figure 8-8). Following the procedures prescribed in section 8.5.1, this value should be multiplied by the air velocity reading. The area of the air velocity sensor for the Omega model HH-30 is 0.037 ft^2 [0.0034 m^2]. As an example, by maintaining an air velocity reading of $1811 \pm 108 \text{ ft/min}$ using the Omega air sensor described above, an air flow of $67 \pm 4 \text{ ft}^3/\text{min}$ should be achieved. If an air velocity sensor other than the Omega model HH-30 is being used, the same conversions apply.

$$\text{Airflow} = \text{Air Velocity} \times \text{Area of Opening (Air Velocity Sensor)}$$

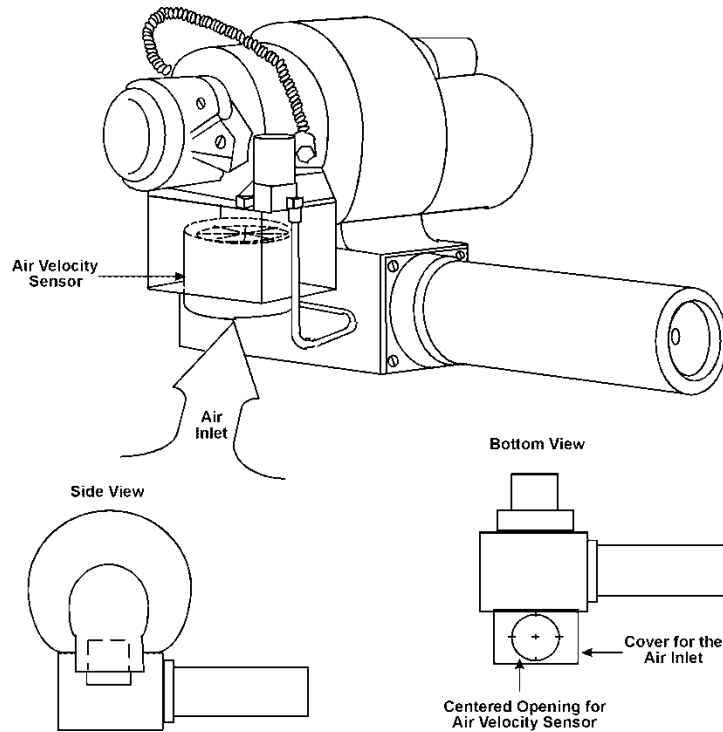

Figure 8-8. Illustration for the Location of the Air Velocity Sensor

8.3.6.4 Test Chamber

A suitable test chamber must be used to reduce or eliminate the possibility of test fluctuation due to air movement. **Although not required, the recommended minimum of the test chamber floor area is 15 feet by 15 feet (4.57 m by 4.57 m) or larger.**

NOTE: Smaller test cells may experience significant increases in ambient air temperature while testing. This may increase the severity of the test.

8.3.6.5 Ventilation Hood

The test chamber must have an exhaust system capable of removing the products of combustion expelled during the tests.

8.3.6.6 Test Chamber Anemometer

A handheld vane-type or hot-wire type air velocity sensing unit capable of measuring accurately in the 0-100 ft/min range must be used to monitor the flow of air inside the test chamber when the ventilation hood is operating. Air flow measurements should be taken at the beginning of the day prior to operating the test burner as described in section 8.5.4.

NOTE: A suitable hotwire anemometer, which may be mounted to the sample test frame, is manufactured by Dwyer Instruments, model number 641-6-LED. A suitable handheld hotwire anemometer is manufactured by TSI, model number 9515.

8.4 Test Samples

8.4.1 Sample Configuration

Each cargo liner panel type and design configuration will be tested. Design configuration includes cargo compartment design features such as corners, joints, seams, lamp assemblies, pressure relief valves, temperature sensors, etc., that may affect the capability of a cargo compartment to safely contain a fire (details in section 8.7.9).

8.4.1.1 Ceiling and sidewall liner panels may be tested individually provided a baffle of fire-resistant material, such as Superwool® or Marinite, is used to simulate the missing panel.

8.4.2 Sample Number

A minimum of three samples or a sample set for each panel type or design configuration will be prepared for testing.

8.4.3 Sample Panel Size

The sample panels to be tested will measure 16 ± 0.125 inches (406 ± 3 mm) by 24 ± 0.125 inches (610 ± 3 mm).

8.4.4 Sample Conditioning

The samples will be conditioned at $70^\circ \pm 5^\circ\text{F}$ ($21^\circ \pm 3^\circ\text{C}$) and $55\% \pm 10\%$ relative humidity for a minimum of 24 hours prior to testing.

8.5 Preparation of Apparatus

8.5.1 The air intake of the oil burner must be completely sealed except for an opening where the air monitoring device will be placed. With the anemometer setup for measuring, turn the motor on and run it for at least 30 seconds to allow the blower to reach its operating speed (it is not necessary for the ignitor and fuel flow to be turned on). Set the airflow to 67 ± 4 ft³/min (1.89 ± 0.11 m³/min) by adjusting the air shutter (airflow conversion located in section 8.3.6.3). Once this airflow value is attained, keep the air shutter in position by tightening the lock screw. This will be the initial airflow setting. Later adjustments may be necessary to reach calibration temperatures and heat flux within the specified airflow range.

NOTE 1: An alternate method of airflow measurement involves removing the burner extension from the end of the draft tube. Turn on the blower portion of the burner without turning on the fuel or igniters. Measure the air velocity using a hot-wire anemometer. Adjust the airflow using the damper so that the airflow is in the range of 1550 to 1800 ft/min (787 to 914 cm/second). (If tabs are being used, the tabs should be removed prior to measuring the airflow. After the measurement is complete, reinstall the tabs and the cone extension).

NOTE 2: If a sonic type burner is to be used, see Chapter 8 Supplement for all test burner information

8.5.2 The fuel flow rate will be 2.0 ± 0.1 gal/hr (7.57 ± 0.38 L/hr).

NOTE 1: If a calibrated flow meter is not available, measure the fuel flow directly using a length of Tygon® tubing and appropriately sized graduated cylinder. Slip the Tygon® tubing over the end of the fuel nozzle, making certain to establish a good seal. Direct the exit of the Tygon® tubing into a small bucket or other collection basin. Turn on the fuel solenoid, making sure the ignition system is off. After establishing a steady stream of fuel flow, simultaneously direct the tubing exit into the graduated cylinder while beginning the stopwatch or timing device. Collect the fuel for a 2-minute period, making certain to immediately direct the tubing exit away from the graduated cylinder at precisely 2 minutes. Calculate the flow rate and ensure that it is 2 ± 0.1 gal/hr (7.57 ± 0.38 L/hr). If the flow rate is not within the tolerance, adjust the fuel pressure accordingly.

NOTE 2: It is important to establish a steady stream of fuel before starting the fuel flow measurement process. It is recommended the fuel flow steadily from the hose for a minimum 10-second period before collecting fuel in the graduated cylinder.

8.5.3 Mount a test sample on the test sample frame. Level and center the sample test frame assembly to ensure proper alignment with the burner cone. **With the sample and test frame in the test position above the burner cone,** check for proper alignment (i.e., distance from exit of burner cone to face of test sample, proper sample position with respect to cone centerline, etc.). The movable burner or sample frame should incorporate mechanical stops or detents to ensure correct positioning without measurement during testing.

8.5.4 Turn on the ventilation hood for the test chamber. Do not turn on the burner air, fuel, or ignition. With the sample still in place, measure the airflow in the test chamber using a handheld vane-type anemometer or equivalent measuring device. The vertical air velocity within a 12-inch (30.5 cm) radius from any point on the horizontally-positioned sample must be less than 100 ft/min (50.8 cm/second). **The horizontal air velocity within a 12-inch (30.5 cm) radius from any point on the sample must be less than 50 ft/min (25.4 cm/second).**

NOTE 1: Airflow measurements do not have to be taken for each sample tested. It is recommend the airflow measurements be taken at the at the beginning of the day before testing, and at the end of the day when testing is completed.

NOTE 2: Personnel present within the test cell may influence air velocity readings. This may be avoided by mounting the anemometer instrumentation to the sample mounting frame during test cell air velocity measurements.

8.5.5 The temperature of the test chamber should be between 50°F and 100°F (10°C and 38°C) before the start of each test. The chamber air temperature should be measured at the same height as the center of the test sample, within 12 inches (30.5 cm) laterally.

8.5.6 Remove the sample from the test frame. Do not use this sample for testing. The sample may be kept for future test chamber airflow and temperature measurements.

8.6 Calibration

8.6.1 Secure the calorimeter in its bracket and place it on the sample mounting test frame, making sure it is centered over the burner cone at a distance of 8 ± 0.125 inches (203 ± 3 mm) from the exit of the burner cone, as shown in figure 8-6. Ensure that the burner is in the proper position relative to the sample mounting frame, 2 ± 0.125 inches (51 ± 3 mm) from

the sidewall panel frame. Position the center of the calorimeter over the center of the burner cone.

8.6.2 Prior to starting the burner, ensure that the calorimeter face is free of soot deposits and that there is water running through the calorimeter.

NOTE: Exposing the calorimeter to the burner flame without water running through it will destroy the calorimeter.

8.6.3 Rotate the burner from the test position to the warmup position. Examine and clean the burner cone of any evidence of buildup of productions of combustion, soot, etc.

NOTE: A stainless steel wire brush is one possible cleaning tool. Soot buildup inside the burner cone can affect the flame characteristics and cause calibration difficulties. Since the burner cone may distort with time, dimensions will need to be checked periodically.

8.6.4 While the burner is in the warmup position, turn on the fuel flow and light the burner. Allow it to warm up for at least 2 minutes. Move the burner into test position and adjust the air intake to produce a heat flux of 7.5 BTU/(ft² second) (8.6 W/cm²) or greater. Record the heat flux measurements at least once per second averaged over a 30-second time period to ensure that steady-state conditions have been achieved. After steady-state conditions have been achieved, turn the burner off.

NOTE: The airflow should be adjusted to produce the proper flame as well as the proper temperature and heat flux density. Two different flame profiles may yield the same temperature and heat flux density. The correct flame is generally 8 to 10 inches in length and orange-yellow in color.

8.6.5 Replace the calorimeter bracket with the thermocouple rake. Check the distance of each of the seven thermocouples to ensure that they are located 8 ± 0.125 inches (203 ± 3 mm) from the horizontal plane of the burner exit. Place the center thermocouple (thermocouple number 4) over the center of the burner cone exit (figure 8-7).

8.6.6 Turn on the burner and allow it to warm up for at least 2 minutes. **After warmup, move the burner into the test position and allow one minute for thermocouple stabilization, then** record the temperature of the thermocouples at least once per second averaged over a 30-second time period. The temperature of each thermocouple will be 1600°F (871°C) or greater.

8.6.7 If the temperature of each thermocouple is not within the specified range, repeat sections 8.6.1 through 8.6.6 until all parameters are within the calibration range. When required thermocouple temperatures have been achieved, check that the airflow is within the required range. Once the parameters are within the specified range, secure the air shutter by tightening the lock screw.

NOTE: Static disks were developed to stabilize the air before entering the combustion area, and are an optional feature. Disks 1 and 2 (figure 8-9) are made for easy assembly, only requiring the removal of the draft tube and installation of the disk. Both are made of steel. Disk 3 is made of a Nomex honeycomb material. Disks 1 and 2 were designed by Park Oil Burner Manufacturing Company of Atlantic City, New Jersey. Disk 3 was developed by CEAT, the French Ministry of Defense. These disks are used in whatever combination of one or more that will produce a more full and even flame pattern. For example, CEAT uses two

honeycomb disks positioned behind the stator. However, given that there are various makes and models of burners used throughout the industry, there is no exact prescription for achieving calibration using a disk(s).

8.6.8 Calibrate prior to each test until consistency (heat flux and temperature remaining within calibration tolerance) has been demonstrated. After consistency has been confirmed, several tests can be performed with calibration conducted before and after the tests.

NOTE 1: Recommendations for achieving calibration temperatures and heat flux:

- 1. Set the stator 3.25 ± 0.25 inches from the end of the draft tube.*
- 2. Rotate the igniter to the 6 o'clock and 9 o'clock position (viewpoint: looking toward the stator from the end of the draft tube).*
- 3. Seal all possible air leaks around the burner cone and draft tube area.*
- 4. Use static disk to improve flame characteristics (figure 8-9).*
- 5. Replace thermocouples after 50 hours of use.*

NOTE 2: If a sonic type burner is to be used, see Chapter 8 Supplement for all test burner information.

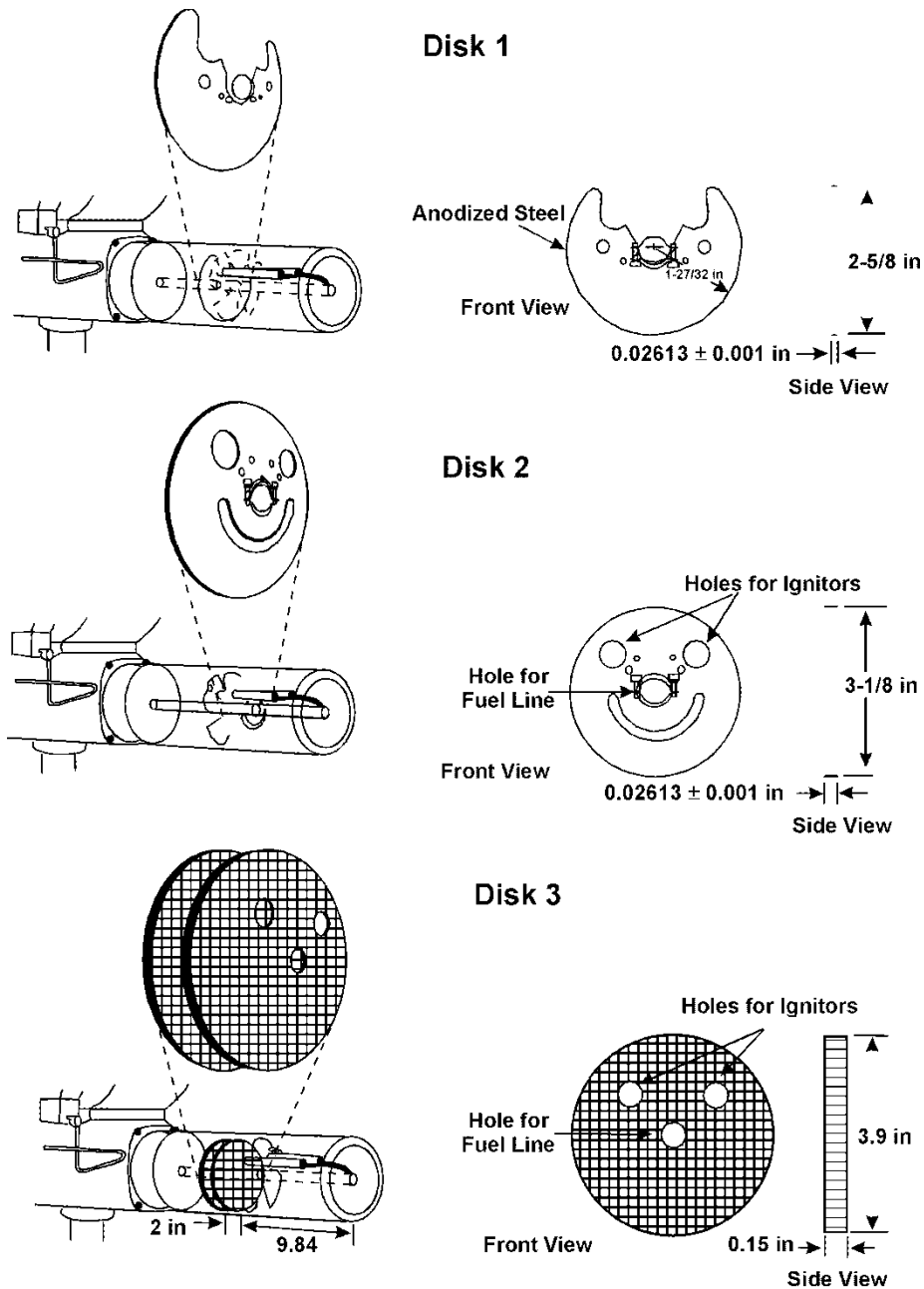

Figure 8-9. Static Disk Illustration

8.7 Procedure

8.7.1 Examine and clean the cone of soot deposits and debris.

8.7.2 Mount the sidewall and/or ceiling cargo liner sample panel(s) on the respective frame(s) and secure to the test frame(s) using the retaining frame(s). Bolt the retaining frame(s) and the test frame(s) together. Verify that the horizontal test frame is level.

8.7.3 Mount the 0.0625-inch backside temperature thermocouple or 0.0625-inch thermocouple rake 4 ± 0.125 inches (102 ± 3 mm) above the top side of the horizontal ceiling

sample test panel as shown in figure 8-3 (details in section 8.3.5). If the thermocouple rake is being used, position the center thermocouple (thermocouple number 4) over the center of the burner cone exit.

NOTE: The 0.125-inch thermocouple rake used for the sonic burner flame consistency validation measurement may not be used for measuring the backside temperature of the test sample. The larger diameter 0.125-inch thermocouple will not respond to changes in temperature as quickly as a 0.0625-inch diameter thermocouple.

8.7.4 Move the burner or sample test rig into the warmup position so that the flame does not impinge on the test sample during the warmup period. Turn on the burner and allow it to stabilize for at least 2 minutes.

8.7.5 Move the burner or sample test rig into the test position, and simultaneously start the timing device when the burner or sample test rig is fully in the test position.

8.7.6 Record the temperature of the thermocouple (thermocouple number 4, if using the 0.0625-inch thermocouple rake also used for calibration) at least once a second for the duration of the test.

8.7.7 Expose the sample to the flame for 5 minutes or until flame penetration occurs.

8.7.8 Turn off the burner to terminate the test.

8.7.9 The following sections present testing procedures for patch repairs, seams, joints, fastening systems, lighting fixtures, and corners.

8.7.9.1 Patch Repairs

Additional guidance and testing information for cargo liner patch repairs can be found in chapter 15 of the Fire Test Handbook.

8.7.9.2 Seams, Joints, Fastening Systems, Lighting Fixtures, and Corners

The barrier material used for design features such as recessed lighting fixtures and pressure relief valves will be tested in the same manner as a cargo liner sample. Seams, joints, and fasteners in the ceiling position will be tested longitudinally extending the length of the liner and centered over the burner cone. Seams or joints used on the sidewall will be positioned longitudinally, 2 inches from the top of the vertical test sample panel as representative of the aircraft application. Apply the test procedures in sections 8.6.1 through 8.6.8 to test these design features.

NOTE: Test procedures for cargo liner design features are described in FAA Technical Note DOT/FAA/CT-TN88/33, dated September 1988. The sample holder must not add reinforcement to any construction that does not exist as installed in the aircraft.

8.8 Report

8.8.1 Report a complete description of the material(s) being tested, including manufacturer, thickness, etc.

8.8.2 Report the orientation of the panels tested (i.e., ceiling and/or sidewall).

8.8.3 Record any observations regarding the behavior of the test sample during flame exposure, such as delamination, resin ignition, smoke, etc., and the time each event occurred.

8.8.4 Report the time of occurrence of flame penetration, if applicable, for each of the three samples tested.

8.8.5 If flame penetration does not occur, report the maximum backside temperature and time of occurrence.

8.8.6 Provide a record of burner flame calibration if a Park type burner is used, or flame validation record if a sonic type burner is used. Specify if a Park or sonic type burner is used.

NOTE: Although not required, it may be useful to record the date, time, ambient air temperature, humidity level, and any other data that may be used to study the burn characteristics of the samples.

8.9 Requirements

8.9.1 None of the three samples tested will burn through within the 5-minute flame exposure.

NOTE: Flames may appear on the sample backside (side of the sample facing away from the burner) resulting from the ignition of flammable smoke and/or gases produced from the sample when subjected to the burner flame. This does not constitute burnthrough. Burnthrough occurs only if the flame from the burner passes through the sample material. While there are no specific requirements related to backside burning, more than 60 seconds of burning on the backside is indicative of a less reliable material. However, the sample material is considered to be a failure should the 400°F criteria be exceeded.

8.9.2 Each of the three samples tested will not exceed 400°F (204°C) at the backside temperature monitored during flame exposure.

8.9.3 Samples that pass in the ceiling orientation may be used as a sidewall panel without further test.

8.9.4 For the patch adhesion test, the patch must be intact after the 5-minute flame exposure.

Chapter 8 Supplement Sonic Burner

Apparatus

The test sample frame must be capable of moving away from the stationary burner during warmup (figure 8-S-1). The recommended distance between the sample frame and burner cone during burner warmup is 36 inches (914.4 mm).

NOTE: The sample frame may be positioned closer to the burner cone during warmup but may create a more severe test condition.

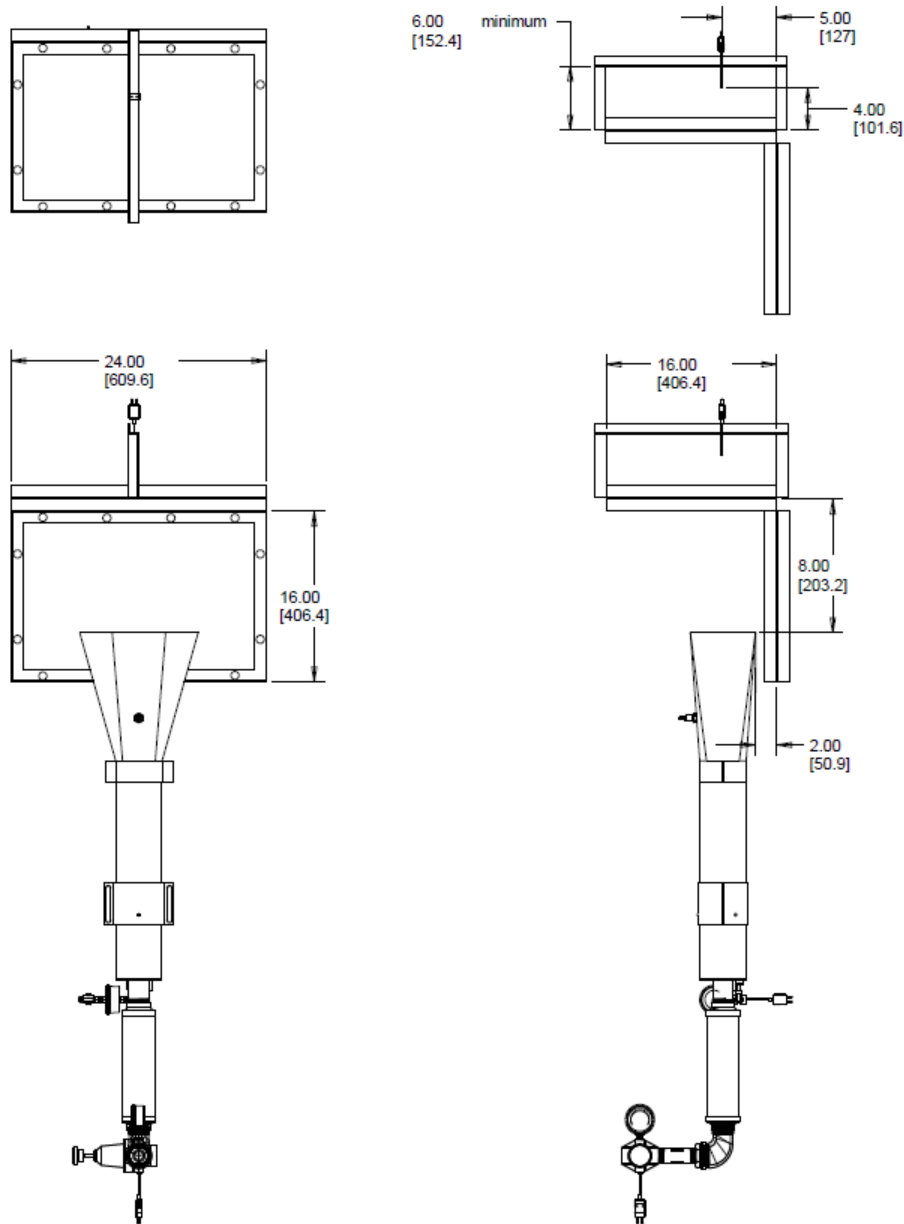

Figure 8-S-1. Test Apparatus for Horizontal and Vertical Mounting for Cargo Liner Oil Burner Testing

Test Burner

This section describes in detail the Federal Aviation Administration Next Generation Fire Test Burner (NexGen), also known as the Sonic burner. The Sonic burner is specified in multiple FAA fire test methods, although certain burner adjustments differ according to each specific test method.

The burner is a gun-type, using a pressurized, sprayed fuel charge in conjunction with a ducted air source to produce the burner flames. An interchangeable, screw-in fuel nozzle will be used to produce the conically-shaped fuel charge from a pressurized fuel source. A pressurized air source controlled via a regulated sonic nozzle will supply the combustion air. The combustion air will be ducted through a cylindrical draft tube containing a series of diffusing vanes. There are several types of internal vanes used to diffuse the combustion air. The diffused combustion air will mix with the sprayed fuel charge in a bell-shaped combustion cone. The fuel/air charge will be ignited by a high-voltage spark plug positioned in the burner cone. Flame characteristics can be adjusted by varying the pressure of the regulated air into the sonic nozzle, **and proper positioning of the fuel spray nozzle**. A schematic of the Sonic fire test burner is displayed in figure 8-S-2.

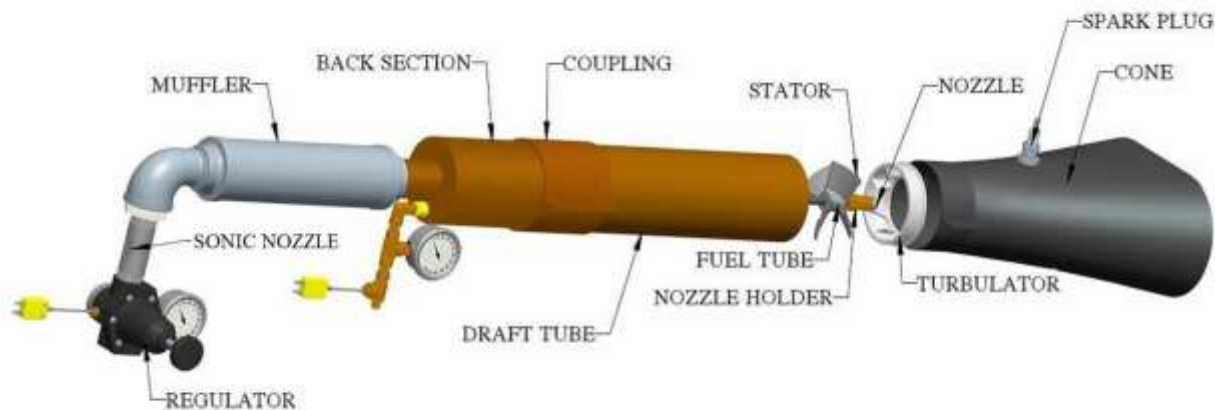

Figure 8-S-2. Schematic of the Sonic Burner - Exploded View

Burner Housing

The burner housing is comprised of three main sections, the draft tube, the coupling, and the back section. The draft tube is constructed of 4-inch inner diameter steel tubing with a wall thickness of 0.125-inch (3.2-mm). The length of the draft tube is 15 inches (381 mm), with 3 inches (76.2 mm) of the tube inserted into the coupling, resulting in a coupling-to-tip distance of 12 (304.8 mm) inches (figure 8-S-3). The coupling is constructed of 4.25-inch (108-mm) inner diameter steel tubing that is 4 inches (102 mm) long with an outer diameter of 4.75 inches (120.7 mm). Three set-screw holes are 120 degrees apart and are drilled 1 inch (25.4 mm) in from the edge to hold the draft tube in place. The coupling has two mounting brackets welded to the sides for easy mounting and adjustment (figure 8-S-4). The back

section is made of the same 4-inch (101.6-mm) tubing as the draft tube, but is 6 inches (152.4 mm) long, with 1 inch (25.4 mm) inserted into the coupling and welded in place (figure 8-S-5). A back plate is constructed of a 0.25-inch (6.4-mm) steel plate cut into a 4.25-inch (108-mm) diameter circle to cap the back section, with holes for the air inlet and fuel inlet (figure 8-S-6). A 1.5-inch National Pipe Thread (NPT) pipe nipple is cut to a length of 2.90 inches (73.7 mm) and welded into the 1.90-inch (48.3-mm) diameter recess cut to a depth of 0.145 inches (3.68 mm) on the center of the back plate (figure 8-S-7).

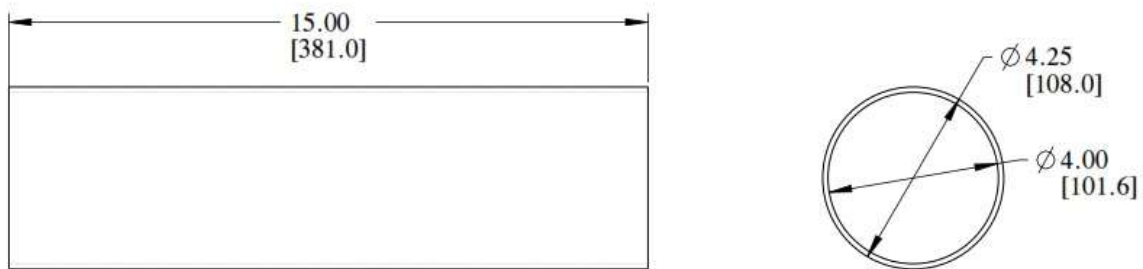

Figure 8-S-3. Dimensioned Drawing of the Draft Tube

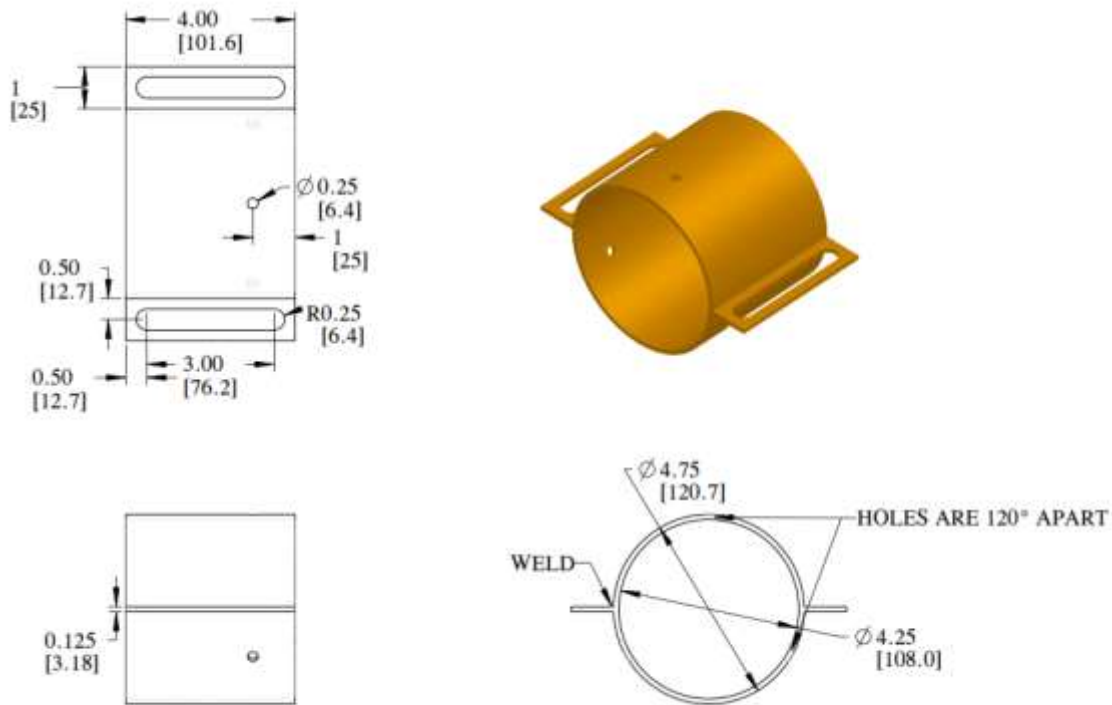

Figure 8-S-4. Dimensioned Drawing of the Coupling

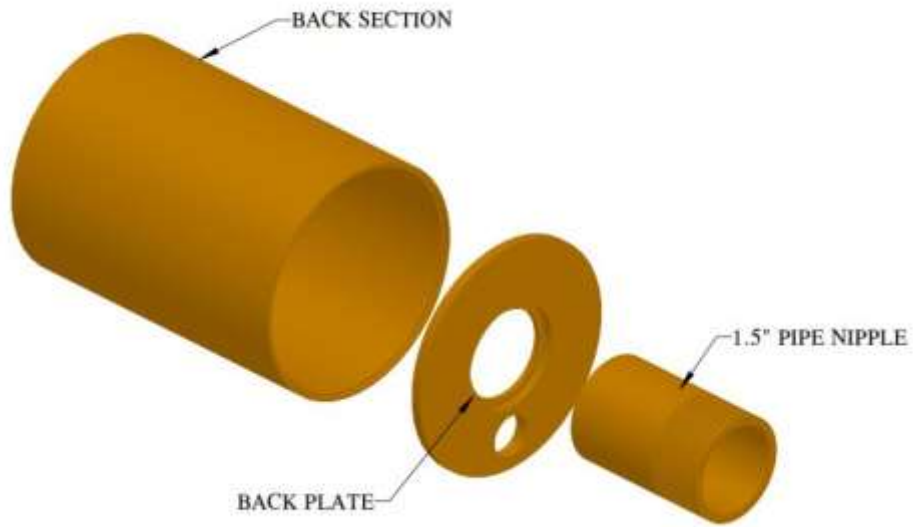

Figure 8-S-5. Back Section Components - Exploded View

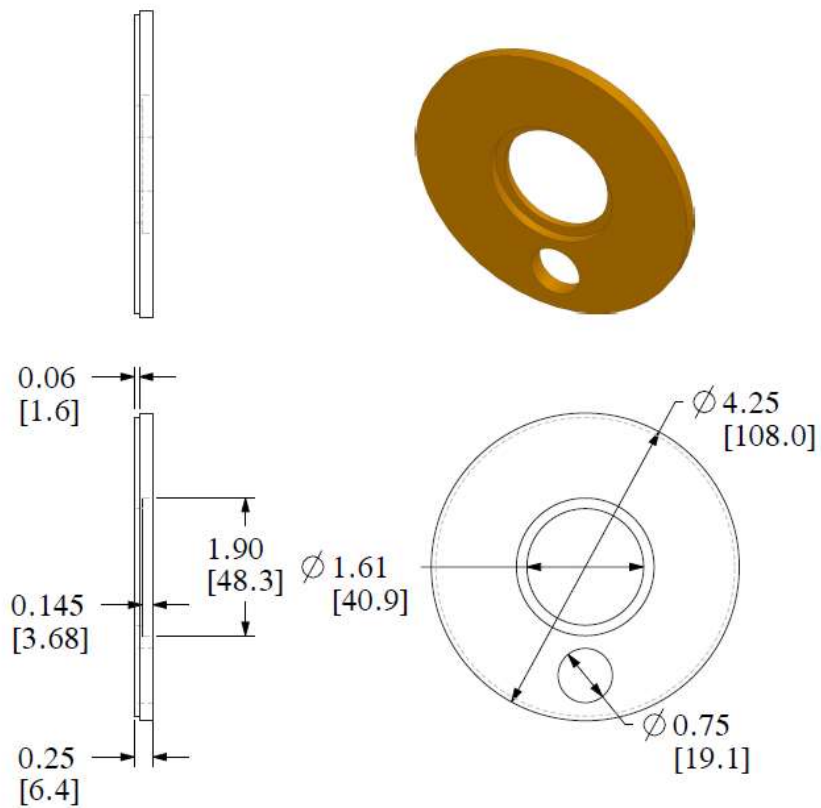

Figure 8-S-6. Dimensioned Drawing of the Back Plate

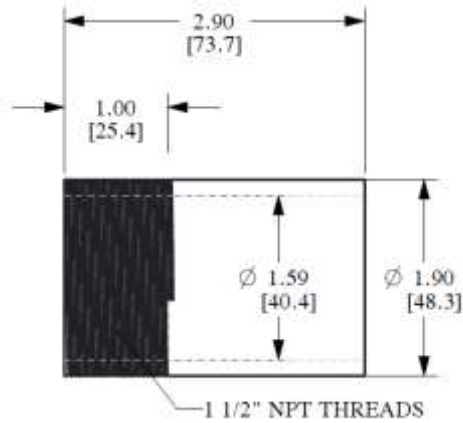

Figure 8-S-7. Dimensioned Drawing of the Pipe Nipple

Sonic Nozzle

The Sonic burner airflow is regulated with a sonic nozzle, which will deliver a constant mass flow rate depending on the supplied inlet air pressure (figure 8-S-8). The nozzle is constructed from stainless steel with 1-inch NPT male thread ends. The throat diameter must be 0.25 inches (6.3 mm), which will deliver a mass flow rate, in standard cubic feet per minute, as a function of inlet pressure, in pounds per square inch gauge, at a rate of

$$\dot{m} = 0.89 * P_i + 12.43$$

The exact inlet air pressure, and hence mass flow rate, will be test-method specific and is described in the respective chapter. The nozzle that the FAA has used to develop the Sonic burner is manufactured by Fox Venturi Products of Dover, New Jersey, and is identified by part number 612021-8.

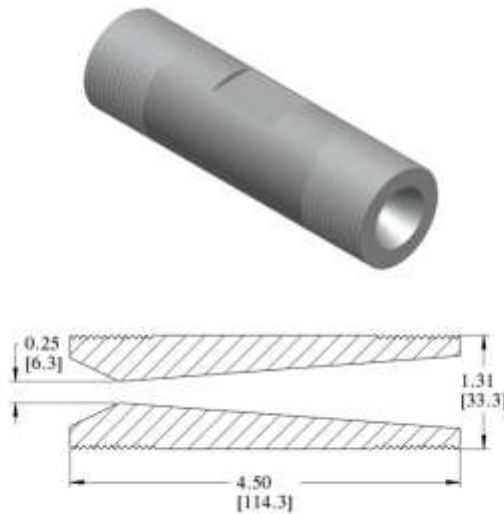

Figure 8-S-8. Schematic of the Sonic Nozzle with Cutaway View Showing Converging and Diverging Interior Sections

Air Pressure Regulator

The air pressure regulator is critical to maintaining the stability of the airflow supplied to the burner. The regulator should have 1-inch NPT female connections, at least one pressure tap for measurement of outlet pressure, and should regulate over the range at which the burner is normally operated (figure 8-S-9). The regulator must also maintain the desired pressure for the duration of a test. A suitable regulator is available from Grainger, item number 4ZM10 (manufactured by Speedaire) with an adjustment range of 5-125 lbs/in² (0.034-0.862 MPa). Another suitable regulator is available from MSC Industrial, part number 73535627, manufactured by Parker (model R119-08CG/M2) with an adjustment range of 2-125 lbs/in² (0.014-0.862 MPa).

NOTE: A 1-inch NPT “tee-fitting” or similar 1-inch NPT fitting may be added between the regulator and sonic nozzle for a more accurate or additional air pressure measurement location.



Figure 8-S-9. Schematic of Air Pressure Regulator with Sonic Nozzle Attached

Air Pressure Measurement Device

The air pressure measured just prior to the sonic nozzle is critical to the proper mass flow rate of air through the sonic nozzle. The pressure gauge or transducer must have NIST (or equivalent) traceable certification with a $\pm 2\%$ accuracy or less. Digital gauges capable of reading in increments of 1 lbs/in² (0.007 MPa) or less are recommended if a pressure transducer is not used. Should an analog gauge be used (figure 8-S-10), it should be glycerin-filled to reduce needle flutter, and have a dial that is easily read. The gauge or transducer must also have a working range appropriately suited for the range of air pressures typically used during tests. A suitable pressure transducer is supplied by Omega Engineering, part number PX329-100G5V. A suitable digital gauge is supplied by Omega Engineering, part number DPG1001B-100G; a suitable analog gauge is supplied by McMaster-Carr, part number 4053K23 with a 0-60 psi (0-0.414 MPa) pressure range.



Figure 8-S-10. Analog Pressure Gauge

Muffler

An air flow muffler is used to reduce the high frequency noise created by the air expanding from the sonic nozzle throat. The 2.625-inch (66.7-mm) outside diameter muffler has 1.5-inch NPT female thread connections, an overall length of 12 inches (305 mm), and has no internal baffles or tubes. A suitable muffler is supplied by McMaster-Carr, part number 5889K73 (figure 8-S-11). Low pressure-drop polyurethane foam must be used to further reduce the noise issuing from the burner. The foam can be cut into a cylinder 3 inches (76.2 mm) in diameter by 12 inches (305 mm) long and should have a density of approximately 1.20-1.50 lbs/ft³ (19.2-24.0 kg/m³) with a porosity of approximately 20 ± 2 pores/inch (787 ± 79 pores/m). It is necessary to affix two pieces of safety wire to the muffler's internal steel mesh at the outlet end to prevent the foam cylinder from moving out of position and into the burner housing. The two wires should be arranged perpendicular to each other in a cross pattern and have a wire diameter of 0.032 inches (0.8 mm) or less (figure 8-S-12). The male outlet of the sonic nozzle connects to a 1-inch NPT female to 1.5-inch male hex reducing bushing. The hex bushing male outlet connects to the intake side of the muffler via a 1.5-inch NPT female to 1.5-inch NPT male, 90-degree, Schedule 40 standard-wall steel street elbow.

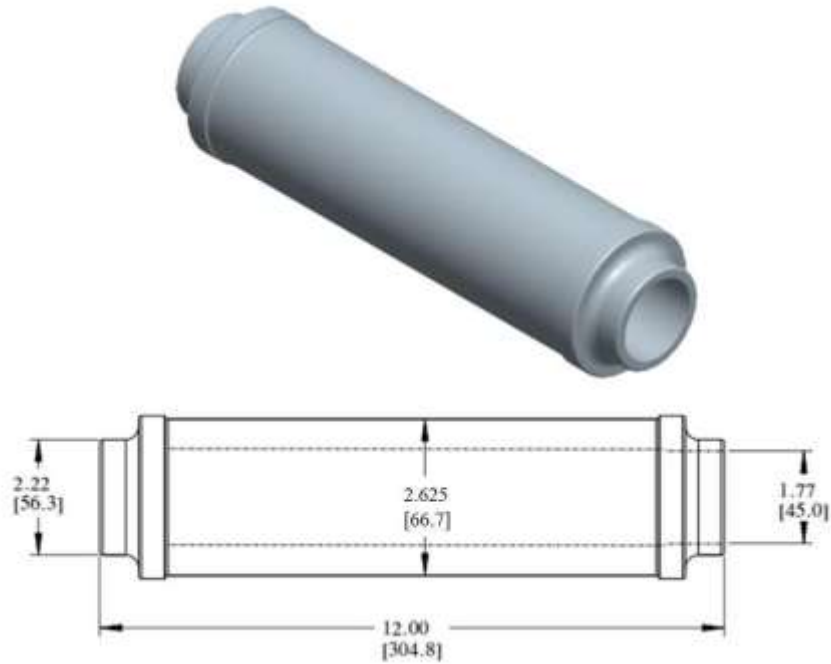

Figure 8-S-11. Schematic of the Muffler

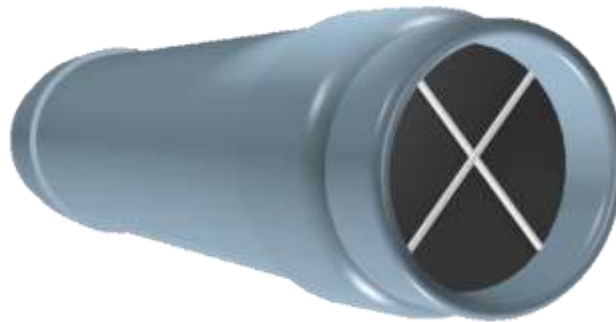

Figure 8-S-12. Safety Wire Affixed to inside of the Muffler for Restraining Foam Insert

Air Temperature

The temperature of the inlet air measured at the sonic nozzle must be maintained at $50 \pm 10^\circ\text{F}$ ($10^\circ\text{C} \pm 6^\circ\text{C}$) for the duration of a test. This can be achieved by constructing a heat exchange system as described later in this section.

Air Diffusion Using Stator and Turbulator

The stator and turbulator are used to deflect and diffuse the airflow within the Sonic burner. Three-dimensional drawing files can be used to fabricate the components on a Computer Numerical Control (CNC) milling machine. These files can be downloaded from the Fire Safety Website:

<http://www.fire.tc.faa.gov/materials/burnthru/nexgen.stm>

Stator

The stator is a four-vane internal component that creates a swirling of internal airflow, and aligns the fuel tube with the center axis of the draft tube (figure 8-S-13). The stator is 4 inches (102 mm) in diameter and should have a snug fit when placed inside the draft tube. A suitable stator is supplied by Marlin Engineering, part number ME1513-3.

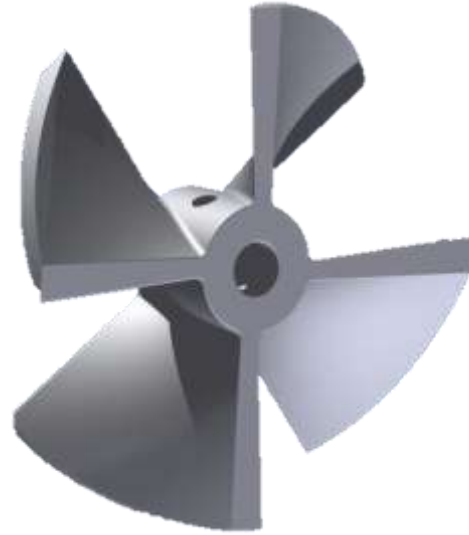

Figure 8-S-13. Stator

Turbulator

The turbulator is a 4-inch (102-mm) diameter component, for air swirling, placed in the end of the draft tube. The center hole is 2.75 inches (69.9 mm) in diameter (figure 8-S-14). A suitable turbulator is supplied by Marlin Engineering, part number ME1512-1.



Figure 8-S-14. Turbulator, Front and Back

Stator and Turbulator Configuration

The stator slides onto the fuel tube, is oriented in the proper direction, and is locked into place with a set screw located at the twelve o'clock position (figure 8-S-15). The turbulator is placed on the end of the draft tube with the tab located at the six o'clock position (figure 8-S-16). The typical configuration positions the face of the stator approximately 2.6875 inches (68.263 mm) from the exit plane of the turbulator (figure 8-S-17). Refer to the Preparation of Apparatus section of this supplement for the exact positioning of the stator and turbulator.

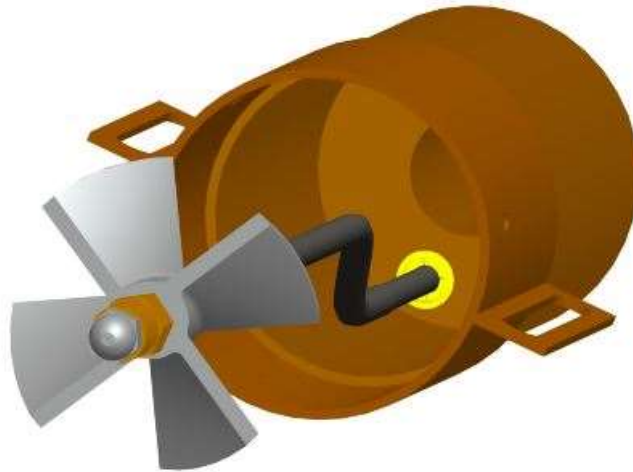

Figure 8-S-15. Location of the Stator on the Fuel Tube



Figure 8-S-16. Position of Turbulator at the end of the Draft Tube

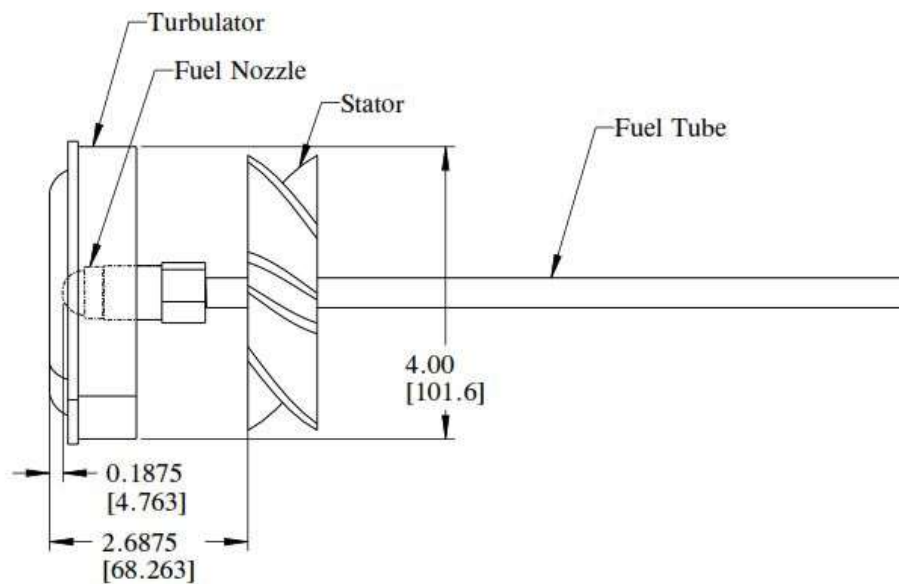

Figure 8-S-17. Typical Configuration of the Stator and Turbulator

Fuel System

A method of fuel pressurization is required to deliver the proper amount of fuel to the spray nozzle for consistent atomization. The delivered fuel pressure is typically in the range of 100 – 120 lbs/in² (0.689 – 0.827 MPa), and must maintain the desired pressure for the duration of a test. A suitable method of fuel pressurization is a pressurized fuel tank (figure 8-S-18). Alternatively, a fuel pump may be used provided it can maintain the required pressure for the duration of a test with minimal fluctuation so as to maintain 2 gal/hr \pm 0.1 gal/hr (7.57 \pm 0.38 L/hr).

A fuel pressure vessel, or tank, such as McMaster-Carr part number 1584K7 with a 15-gallon (56.8-liter) capacity, measuring 12 inches (305 mm) in diameter and 33 inches (838 mm) tall, or 35 inches (889 mm) tall including mounting base, can be used to contain the fuel. The tank has various fittings on the top, bottom, and sides to allow for connection of pipe fittings for filling, discharging, fuel quantity level, pressure measurement, pressurization, and venting. Nitrogen is used to pressurize the headspace of the fuel tank. Solenoid or manual valves can be used to start and stop the flow of fuel, nitrogen, and vent gas. The headspace gas pressure is controlled by a precision regulator, and monitored using a fuel pressure gauge. A high pressure translucent tube can be used for indicating the fuel level in the tank.

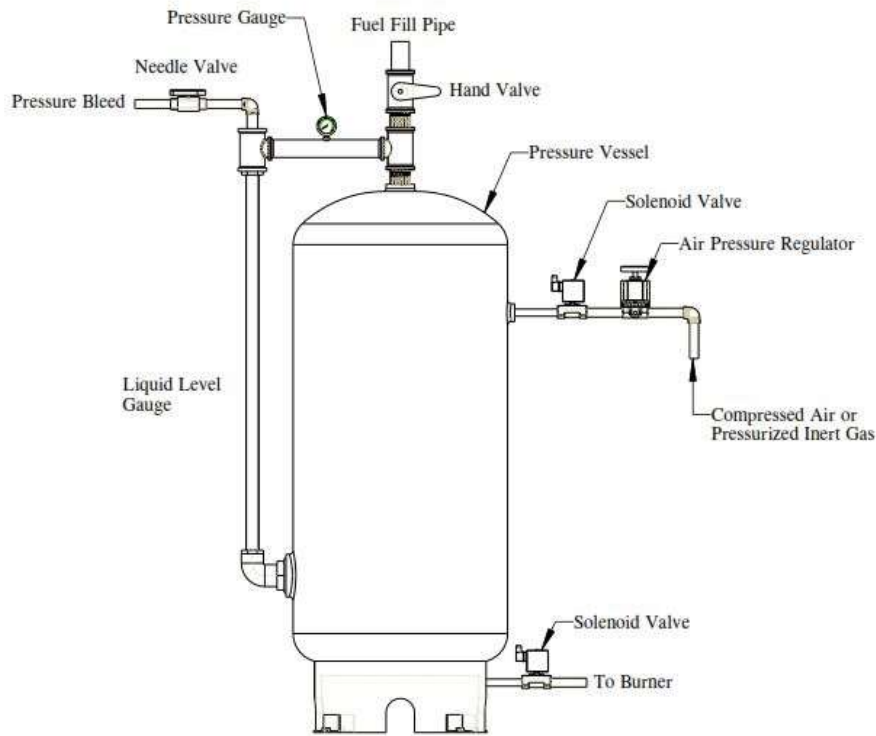

Figure 8-S-18. Schematic of Pressurized Fuel Tank System

Fuel Pressure Measurement Device

A suitable pressure gauge or transducer must be used to monitor the pressure inside the fuel tank, which is critical for establishing the proper flow of fuel into the fuel nozzle. The pressure gauge or transducer must have NIST (or equivalent) traceable certification with a $\pm 2\%$ accuracy or less. If a pressure transducer is not used, digital gauges capable of reading in increments of 1 lbs/in^2 (0.007 MPa) or less are recommended. If an analog gauge is used, it should be glycerin-filled to reduce needle flutter, and have an easily readable dial. The gauge must also have a working range appropriately suited for the range of fuel pressures typically used during tests. A suitable pressure transducer is supplied by Omega Engineering, part number PX329-150G5V. A suitable digital gauge is supplied by Omega Engineering, part number DPG1001B-500G; a suitable analog gauge is supplied by McMaster-Carr, part number 4053K23 with a 0-160 psi (0-1.1 MPa) pressure range (figure 8-S-19).



Figure 8-S-19. Analog Fuel Pressure Gauge

Fuel Temperature

The fuel entering the burner fuel tube must be maintained at a temperature range of $42 \pm 10^\circ\text{F}$ ($5.5 \pm 5.5^\circ\text{C}$) for the duration of a test. This can be achieved by constructing a heat exchange system as described later in this supplement.

Fuel Tube

The fuel tube in the Sonic burner is designed to allow both the fuel nozzle and the airflow to be aligned with the axis of the draft tube. This is accomplished by creating two bends in the section of the fuel tube that enters the back of the burner (figure 8-S-20). The tube is constructed from schedule-80, thick wall, 0.125-inch (3.175-mm) steel pipe with an outside diameter of 0.405-inch (10.287-mm), an inside diameter of 0.215-inch (5.461-mm), and a wall thickness of 0.095-inch (2.413-mm). The tube is cut to a length of approximately 21.5 inches (546.1 mm); a section of the outer wall is removed on a lathe to fit the fuel tube through the keyless bushing that holds the tube in place. The outer diameter of the fuel tube is reduced to approximately 0.3750 inch (9.525 mm) for a length of 4 inches (101.6 mm) at one end. The tube is then shaped with a pipe bender according to the dimensions in the drawing. A die is used to thread both ends of the tube with 0.125-inch NPT pipe threads. Heavy duty 0.004-inch-thick (0.102-mm-thick) thread seal tape is wrapped on the pipe threads to prevent fuel leakage. A 1.375-inch-long (34.925-mm-long) brass fuel nozzle adapter is threaded onto the front end of the fuel tube where the fuel nozzle will be attached. A keyless bushing (Fenner Drives p/n 6202109) is used to hold the back end of the fuel tube in place. A pipe fitting is attached to the back end of the fuel tube to connect the pressurized fuel system to the fuel tube.

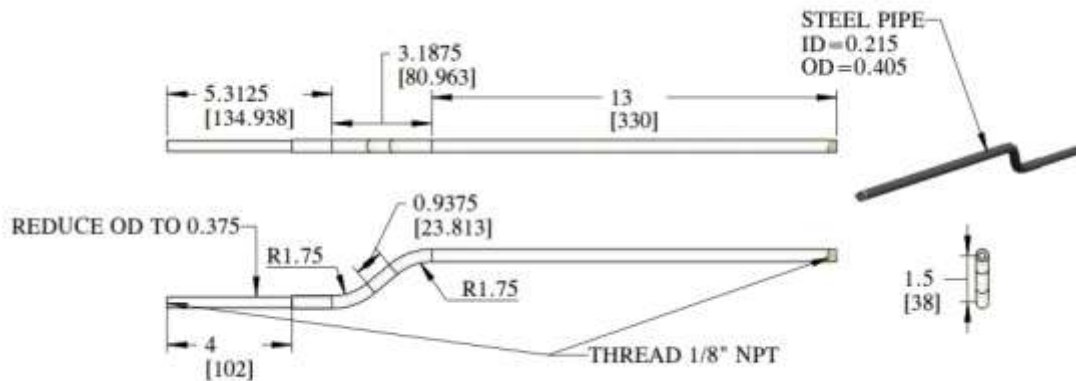

Figure 8-S-20. Schematic of the Fuel Tube

Fuel Nozzle

The fuel nozzle for the Sonic burner should be an 80-degree solid conical spray pattern oil burner nozzle. The nozzle flowrate will depend on the test method. The rated flow rate provided by the manufacturer is achieved when applying a 100 lb/in² (0.71 MPa) pressure to the nozzle. If a different flow rate is desired, the pressure can be adjusted accordingly to achieve a wide range of flow rates. In general, the flow rate is related to the pressure by:

$$F_d = F_r \sqrt{\frac{P_d}{P_r}}$$

In which F_d is the desired flow rate, F_r is the rated flow rate, P_d is the desired pressure, and P_r is the rated pressure, typically 100 psig (0.71 MPa). For example, if a 5.5-gal/hr (20.8 L/hr)-rated nozzle is operated at 120 lb/in² (0.83 MPa), a flow rate of 6.0 gal/hr (22.7 L/hr) will be achieved. A Delavan 80-degree 2.0 gal/hr (7.57 L/hr) B-type spray nozzle has been found suitable for this application.

Nozzle Adapter

The fuel nozzle adapter is a brass fitting 1.375 inches (34.9 mm) in length with a 0.125-inch NPT thread on the inlet side and 0.5625-inch 24 Unified Fine Thread (UNF) thread where the nozzle attaches (figure 8-S-21).



Figure 8-S-21. Fuel Nozzle and Brass Adapter

Fuel

Use jet fuel (JP-8, Jet A, or their international equivalent), or ASTM K2 fuel (Number 2 grade kerosene) to yield the desired fuel flow rate within the specified pressure range for the test method being performed. Diesel fuel may also be used, however the test condition may be more severe.

Ignition

A high voltage oil burner ignition transformer with an output of 10 kilovolts is used to create an arc across an automotive type spark plug mounted in the burner extension cone. The spark plug uses a standard 14 mm diameter thread size with a thread pitch of 1.25 mm. The threaded segment of the spark plug is 0.36 inches (9.1 mm) in length. The exposed portion of the central insulator measures 0.70 inches (17.8 mm) in length. The spark plug gap must be opened to 0.100 inches (2.5 mm) in order to consistently ignite the fuel/air charge in the burner cone (figure 8-S-22). A suitable spark plug is manufactured by Champion Products, manufacturer part number RJ19LM, and can be purchased through Grainger (www.Grainger.com), part number 12U891.

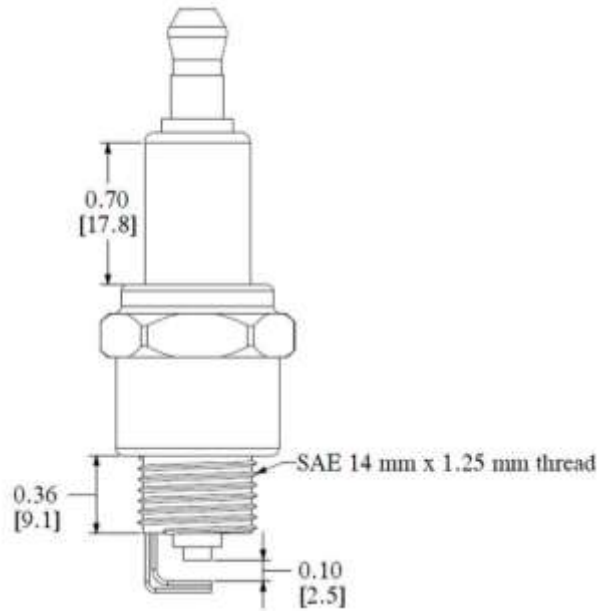

Figure 8-S-22. Dimensioned Drawing of a Spark Plug

Heat Exchange System

A heat exchange system is used to regulate the temperature of the burner inlet air and fuel as the flow rate of each is dependent upon the density of the air and fuel. A schematic of a suitable heat exchange system is displayed in figure 8-S-23. The ice bath can be constructed from an insulated cooler or a chest freezer with temperature control capability. The fuel travels through coiled copper tubing in the ice bath and out to the burner. The air is cooled in a heat exchanger, such as McMaster-Carr part number 43865K78, which has ice water traveling through the outer shell, removing heat from the air. The ice water is circulated in a closed-loop from the cooler to the heat exchanger by means of a submersible pump. The exact dimensions of the copper coils and the flowrate of the water pump will be dependent upon the particular conditions in the laboratory. Alternate methods such as active heating and cooling systems can be used, allowing greater precision, but may be more costly.

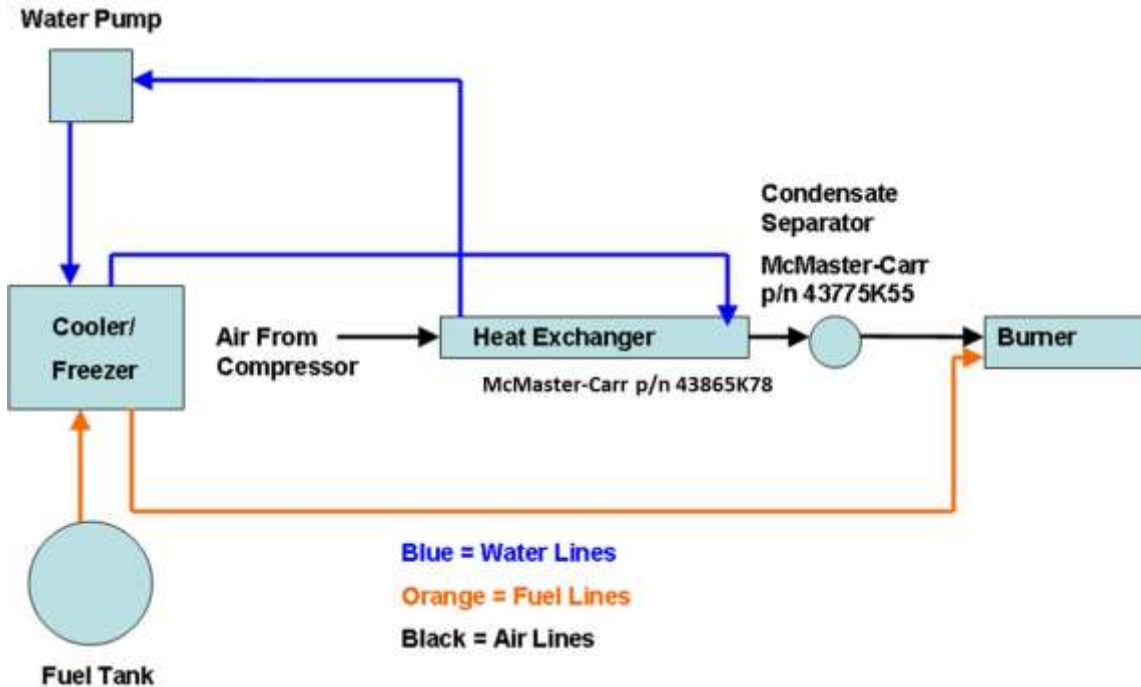

Figure 8-S-23. Schematic of Air/Fuel Heat Exchange System

Burner Cone

A 12 ± 0.125 -inch (305 ± 3 -mm) burner extension cone is fitted to the end of the draft tube. The cone is constructed from 16 gauge American Iron and Steel Institute (AISI) type 310 stainless steel. The cone exit plane must be 6 ± 0.250 inches (152 ± 6 mm) high and 11 ± 0.250 inches (280 ± 6 mm) wide, with a thickness of 0.0625 ± 0.015 inch (1.59 ± 0.381 mm). Refer to figures 8-S-24 and figure 8-S-25 for detailed drawings. The hot and cold cycling that occurs during typical testing can cause the cone exit plane dimensions to shift due to warpage. **It is critical to periodically check the cone exit plane dimensions to ensure they remain within the specified tolerances. It is recommended this check be performed at the beginning and end of each day the burner is operated. A cone found to be out of tolerance should be repaired or replaced before continuing operation of the burner.**

NOTE 1: Park type burner cones are 18 gauge 310 stainless steel or similar alloy while Sonic type burners are 16 gauge 310 stainless steel.

NOTE 2: The welded seam connecting the burner cone mounting flange and burner cone extension should align with the end of the burner draft tube.

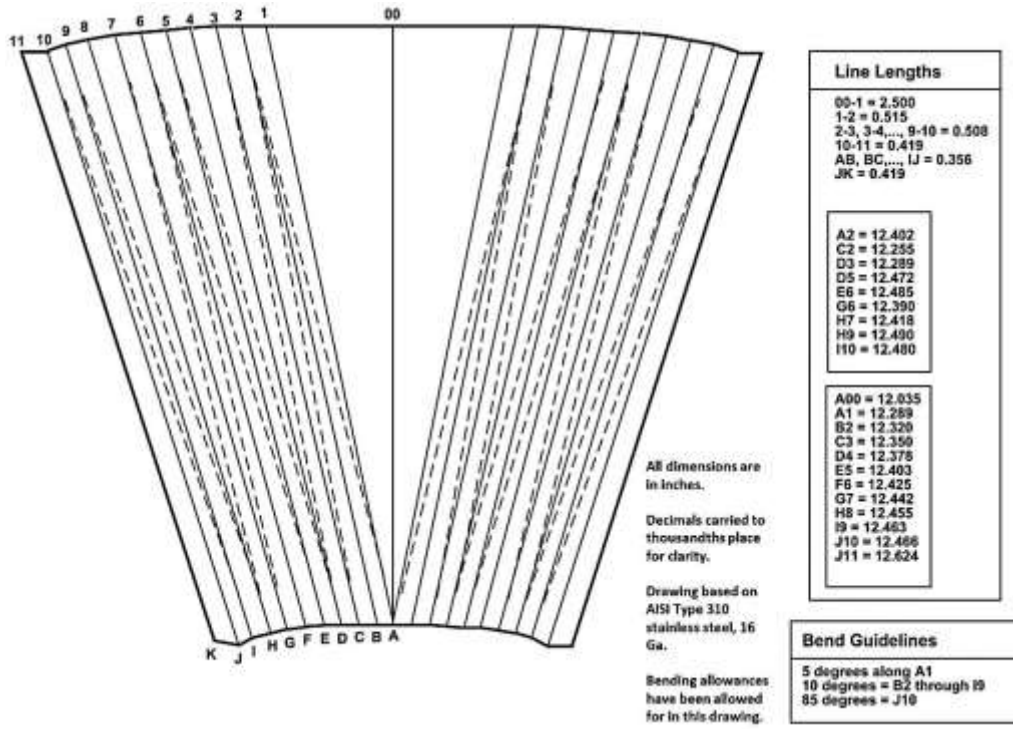

Figure 8-S-24. Burner Cone Layout and Bending Pattern

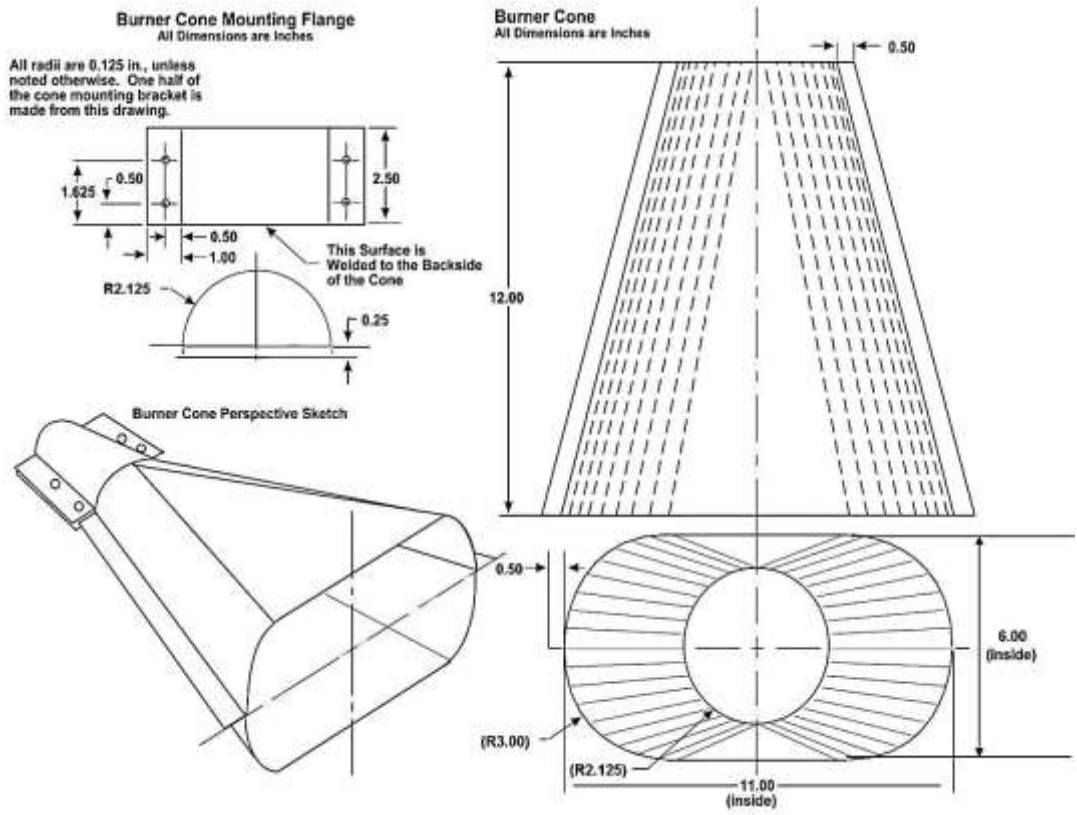

Figure 8-S-25. Burner Cone Details

Threaded Boss for Spark Plug

A threaded boss must be welded to the side of the burner extension cone for acceptance of the spark plug used to ignite the fuel charge. The threaded boss must be fabricated from American Iron and Steel Institute (AISI) type 310 stainless steel. The cylindrical boss must measure 1.125 inches (28.58 mm) in diameter, with a thickness of 0.250 inches (6.4 mm). The boss must be threaded using an SAE standard 14 mm x 1.25 mm spark plug tap (figure 8-S-26).

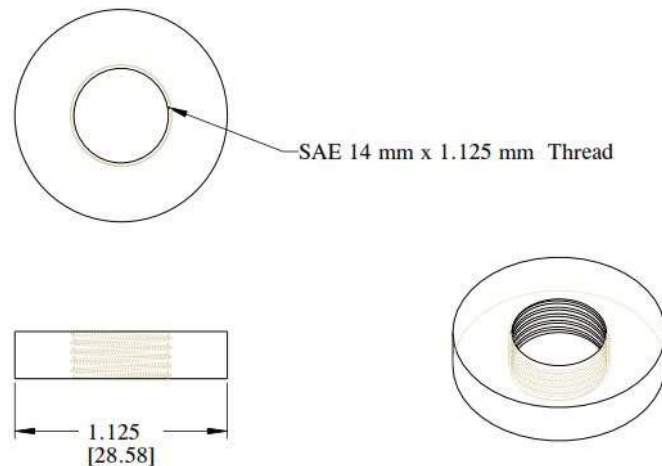

Figure 8-S-26. Threaded Boss

Burner Measurement Locations

Accurate measurements of the Sonic burner inlet parameters are critical to proper operation. The measurement locations of the burner air and fuel supply are typically located just prior to entering the burner housing, or as near the burner housing as possible. An example of acceptable measurement locations of the burner air and fuel supply are indicated in figure 8-S-27.

Air Pressure

The sonic nozzle inlet pressure is measured with a suitable pressure gauge or transducer mounted just upstream from the sonic nozzle. The gauge or transducer should measure accurately in the range of 0-60 lbs/in² (0-0.41 MPa), with an accuracy of $\pm 2\%$ maximum. Bourdon type gauges and pressure transducers have proven to be suitable for this measurement (see details in Air Pressure Measurement Device above).

Air Temperature

The burner air temperature is measured with a 0.125-inch (3.2 mm) diameter, **insulation** packed, 310 stainless steel sheathed, type K (Chromel-Alumel) grounded junction thermocouple with a nominal 24 AWG conductor. The thermocouple should be inserted into the air stream just upstream of the sonic nozzle **with the tip located near the center of the air supply stream**. In some testing situations, flame radiation may be incident upon the inlet air lines, causing heating of the air and possible bursting of flexible hoses. It is important to

shield all air lines with thermal wrapping to prevent an unsafe condition and maintain steady air temperature.

Fuel Pressure

The burner fuel pressure is measured with a suitable pressure gauge (see Fuel Pressure Measurement Device above) mounted in a T-connection in the fuel inlet line near the back of the burner. It is important that the measurement location be as close to the back of the burner as possible to accurately measure the fuel pressure at the point it enters the burner.

Fuel Temperature

The burner fuel temperature is measured with a 0.125-inch (3.2 mm) diameter, **insulation** packed, 310 stainless steel sheathed, type K (Chromel-Alumel) grounded junction thermocouple with a nominal 24 AWG conductor. The thermocouple should be mounted in a T-fitting such that the probe tip is located near the center of the fuel tube. In some testing situations, flame radiation may be incident upon the inlet fuel lines, causing heating of the fuel and possible bursting of flexible hoses. It is important to shield all fuel lines with thermal wrapping to prevent an unsafe condition and maintain steady air temperature.

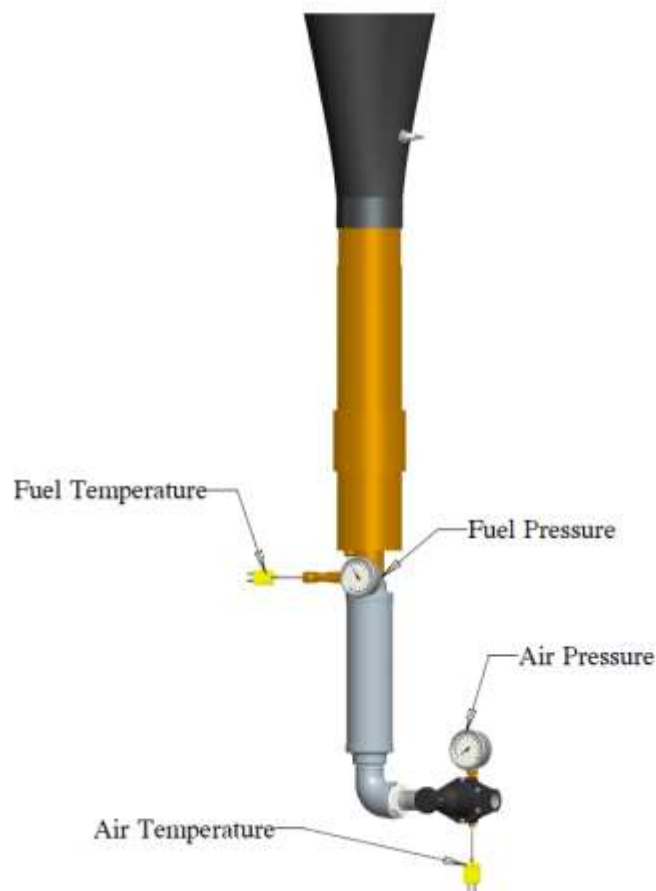

Figure 8-S-27. Burner Schematic Showing Inlet Measurement Locations

Sonic Burner Configuration

Fuel Nozzle Location

The tip of the fuel nozzle, or fuel exit plane, must be located 0.1875 ± 0.020 inch (4.763 ± 0.5 mm) from the exit plane of the turbulator (figure 8-S-28).

Stator Adjustment

The stator is positioned by adjusting its translational position as well as its axial position on the fuel tube.

Stator Translational Position

The front face of the stator must be located 2.6875 ± 0.020 inches (68.263 ± 0.5 mm) from the exit plane of the turbulator (figure 8-S-28). This stator translational position is also 2.5 inches (63.5 mm) from the tip of the fuel nozzle.

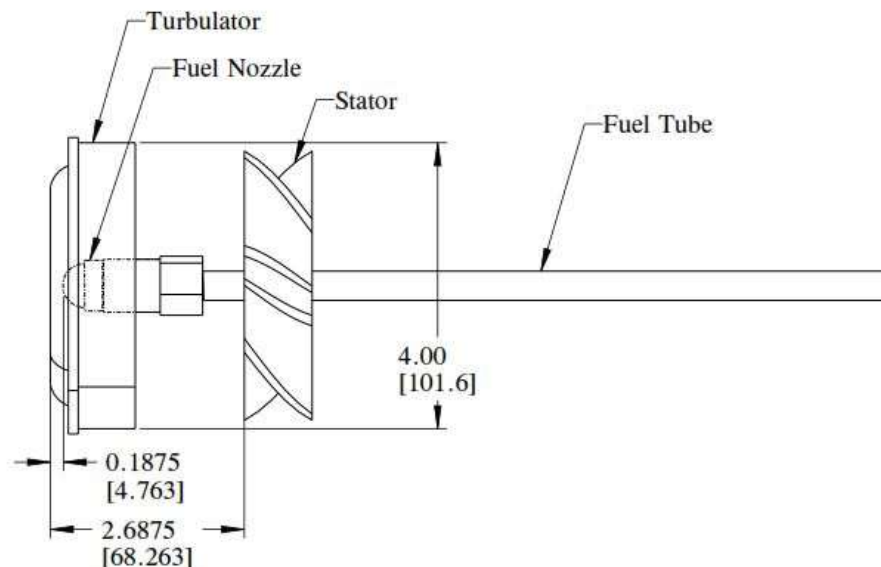

Figure 8-S-28 Fuel Nozzle and Stator Locations

Stator Axial Position

The line running through the set screw and geometric center of stator will be used as a reference for properly orienting the rotational position of the stator. The stator must be positioned so the reference line angle is 0 degrees (12 o'clock) from the zero position when looking into the burner draft tube. (figure 8-S-29).

Note: The 0-degree reference angle is pointed at, and perpendicular to, the inner surface of the sidewall (vertical) sample panel. The stator set screw will be oriented toward the vertical panel while the notch in the turbulator will be oriented away from the vertical panel.

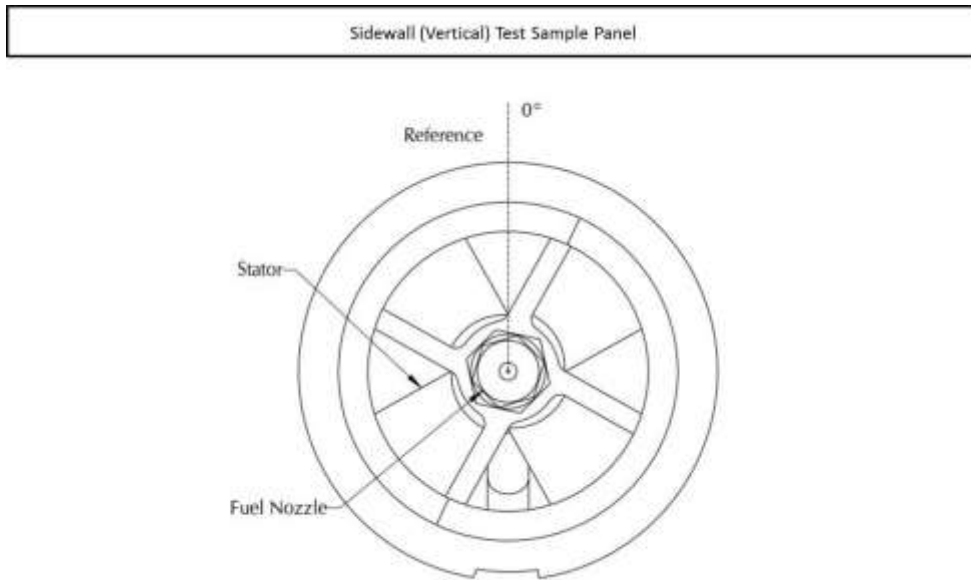

Figure 8-S-29 Stator Axial Position (looking into draft tube)

Spark Plug Location

The spark plug should be mounted in a threaded boss, on the surface of the burner cone facing away from the vertical sample frame. The spark plug is located at a distance 6 ± 0.125 inches (152 ± 3 mm) from the end (intake plane of burner cone) (figure 8-S-30).

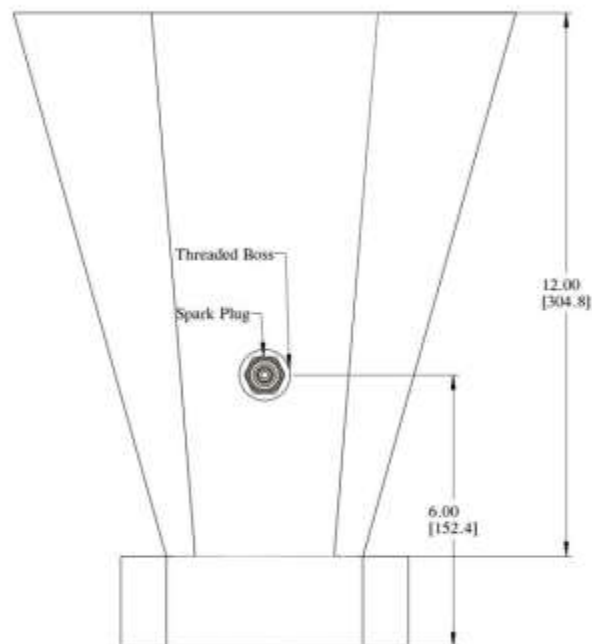

Figure 8-S-30. Spark Plug Location in Burner Cone

Spark Plug Gap

The spark plug gap (distance) between the two electrodes must be 0.100 inches (2.5 mm) as shown in figure 8-S-31.

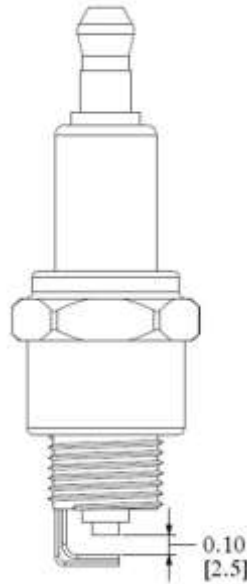
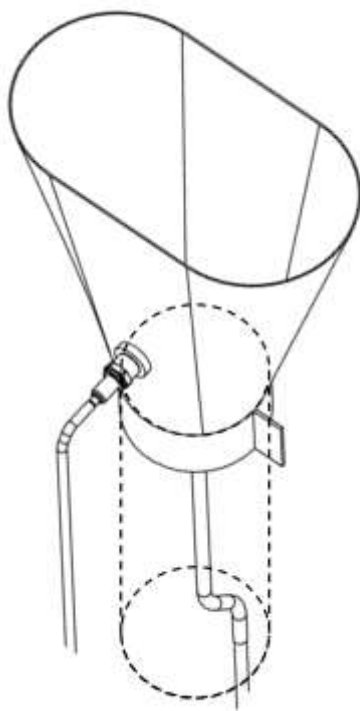

Figure 8-S-31. Spark Plug Gap Measurement

Spark Plug Wire Routing

The length and arrangement of the spark plug wires must be monitored to prevent heat damage during flame consistency validation and testing. Once the air/fuel mixture is ignited, the outside surface temperature of the burner cone will increase rapidly, becoming capable of damaging the wire if it comes in contact with the cone. The spark plug wire should be carefully routed to prevent contact with the cone or other hot surfaces, and should also be shielded in a heat-resistant covering to further protect it from convective heat damage from the burner flames. The wire can be routed as shown in figure 8-S-32, in which the wire does not contact any components in the vicinity of the burner cone.



8-S-32. Proper Routing of the Spark Plug Wires

Volumetric Air Flow Control

The volumetric airflow is controlled via a regulated sonic nozzle. Adjust the upstream supply air pressure to $45 \text{ lbs/in}^2 \pm 1 \text{ lbs/in}^2$ ($0.31 \pm 0.007 \text{ MPa}$). The intake air temperature must be maintained within the range of 40°F to 60°F (4°C to 16°C). For additional details, refer to sections “Sonic Nozzle” and “Air Pressure Regulator” in this supplement.

Fuel Flow Calibration

If a calibrated flow meter is not available, measure the fuel flow directly using a length of Tygon® tubing and appropriately sized graduated cylinder. Slip the Tygon® tubing over the end of the fuel nozzle, making certain to establish a good seal. Direct the exit of the Tygon® tubing into a small bucket or other collection basin. Turn on the fuel solenoid, making sure the ignition system is off. After establishing a steady stream of fuel flow, simultaneously direct the tubing exit into the graduated cylinder while beginning the stopwatch or timing device. Collect the fuel for a 2-minute period, making certain to immediately direct the tubing exit away from the graduated cylinder at precisely 2 minutes. Calculate the flow rate and ensure that it is $2 \pm 0.1 \text{ gal/hr}$ ($7.57 \pm 0.38 \text{ L/hr}$). If the flow rate is not within the tolerance, adjust the fuel pressure accordingly. **Record the fuel pressure necessary to achieve the required fuel flow. The recorded fuel pressure must be monitored and maintained during burner operation, and fluctuate no more than $\pm 2 \text{ lbs/in}^2$ ($\pm 13.8 \text{ kPa}$) during flame consistency validation and sample testing. A flame temperature validation or sample test will**

be void should the fuel pressure fluctuate outside of this range during either procedure. The temperature of the fuel must be maintained within the range of 32°F to 52°F (0°C to 11°C).

NOTE: It is important to establish a steady stream of fuel before starting the fuel flow measurement process. Due to the vertical orientation of the burner, the hose may need to fill with fuel above the fuel nozzle before a steady stream of fuel will flow from the hose. It is recommended the fuel flow steadily from the hose for a minimum 10-second period before collecting fuel in the graduated cylinder.

Instrumentation and Supporting Equipment

Burner Flame Consistency Validation Thermocouples

Seven thermocouples must be used to check the flame temperature of the burner. The thermocouples must be 0.125-inch (3.2-mm) diameter, **insulation** packed, 310 stainless steel sheathed, type K (Chromel-Alumel), grounded-junction with a nominal 24 American Wire Gauge (AWG) size conductor. **Thermocouples purchased with a certificate of calibration may provide more accurate readings but are not required.** The seven thermocouples must be attached to a steel mounting plate to form a thermocouple rake for placement in the test stand during the burner flame consistency validation (figure 8-S-33). **It is recommended the thermocouple mounting plate be a minimum of 8 inches (203 mm) away from the tips of the thermocouples.**

Sample Backside Temperature Thermocouple

A thermocouple will be used to monitor the temperature above the ceiling (horizontal) panel during cargo liner sample testing. The thermocouple must be 0.0625-inch (1.6-mm) diameter, **insulation** packed, 310 stainless steel sheathed, type K (Chromel-Alumel), grounded-junction with a nominal 30 American Wire Gauge (AWG) size conductor. **A thermocouple purchased with a certificate of calibration may provide more accurate readings but is not required.** The thermocouple tip should be a minimum of 2 inches (51 mm) away from any hardware used to mount the thermocouple in the test position.

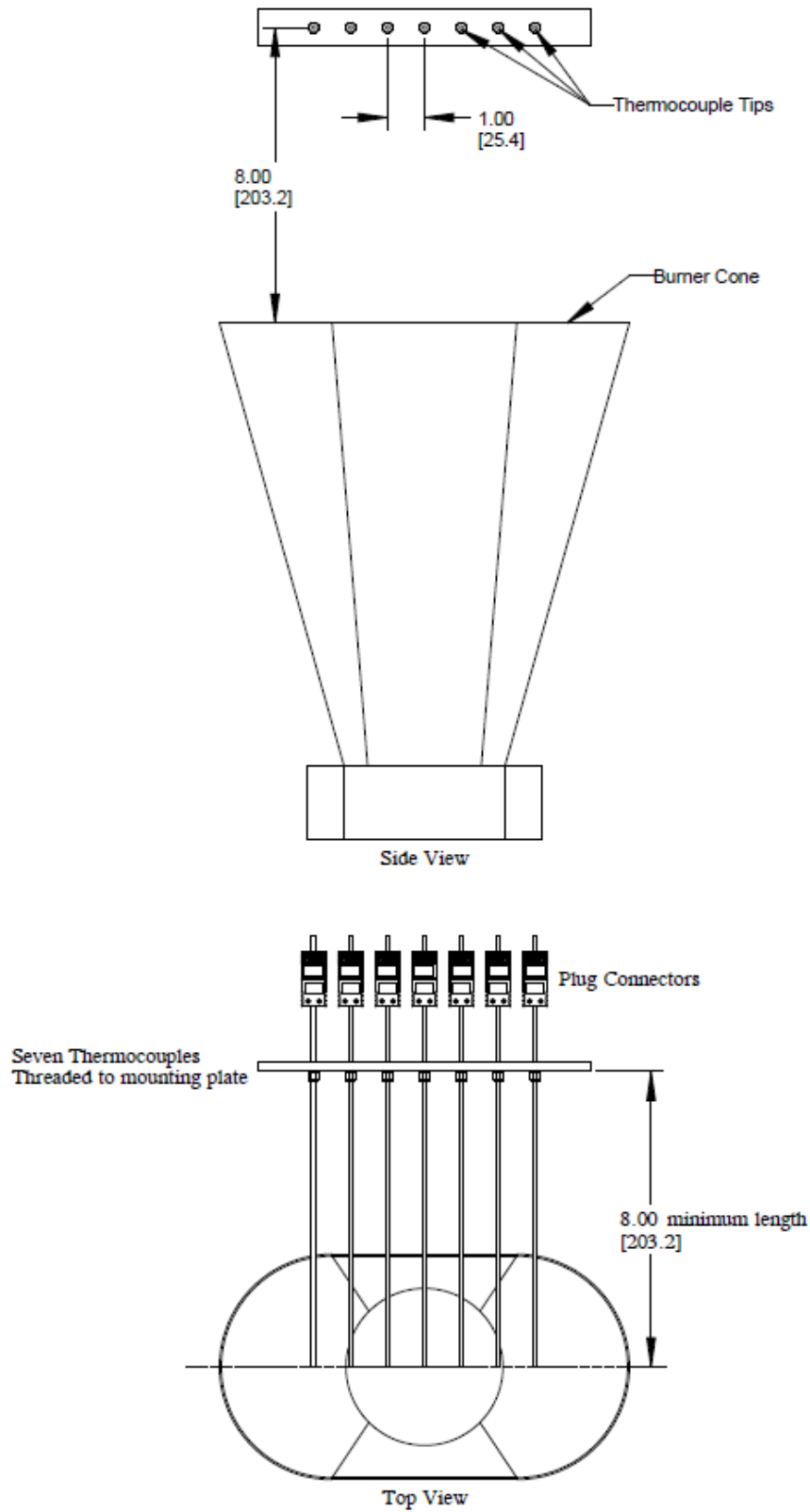

Figure 8-S-33. Side and Top View of Thermocouple Rake Bracket

Burner Flame Consistency Validation

Examine and clean the burner cone of any evidence of buildup of combustion products, soot, etc. Soot build-up inside the cone may affect the flame characteristics and cause difficulties during flame consistency validation. **Check the burner cone dimensions are within specified tolerances before flame validation.**

Mount the thermocouple rake on a movable stand that is capable of being quickly translated into position over the burner. Move the rake into calibration position and check the distance of each of the seven thermocouples to ensure that they are located 8 ± 0.125 inch (203 ± 3 mm) from the horizontal plane of the burner cone exit. Ensure that the horizontal centerline of the thermocouples is directly above the horizontal centerline of the burner cone (figure 8-S-33). Place the center thermocouple (thermocouple number 4) over the center of the burner cone exit. Note that the thermocouple rake movable stand must incorporate detents that ensure proper centering of the thermocouple rake with respect to the burner cone, so that rapid positioning of the rake can be achieved during the validation procedure. Once the proper position is established, move the thermocouple rake away, and move back into the calibration position to re-check distances. When all distances and positions are confirmed, move the thermocouple rake away from burner.

While the thermocouple rake is away from the burner, turn on the spark plug, pressurized air and fuel flow, and light the burner. Allow burner to warm up for a period of 2 minutes. After warm-up, move the thermocouple rake into position and allow 1 minute for thermocouple stabilization, then record the temperature of each of the seven thermocouples once every second for a period of 30 seconds. Remove the thermocouple rake from flame temperature validation position and turn off burner. Calculate the average temperature of each thermocouple over this period and record. Although not a requirement for testing, the recommended average temperature of each of the seven thermocouples should be $1700^{\circ}\text{F} \pm 100^{\circ}\text{F}$ ($927^{\circ}\text{C} \pm 55^{\circ}\text{C}$). The burner should be rechecked to ensure it is configured properly if temperatures are measured outside of this recommended range. **A flame that appears biased to one side, or produces significantly higher temperatures on one end of the flame validation thermocouple rake, may indicate an adjustment of the fuel nozzle and/or internal stator orientation and/or distance from the end of the draft tube may be necessary, provided the adjustments are within allowable tolerances.** If no problems are found with the burner, any thermocouple reading outside of this range may require replacement. **It is recommended that the burner flame temperature be validated at the beginning and end of each day testing is performed.**

NOTE 1: The thermocouples are subjected to high temperature durations during calibration. Because of this type of cycling, the thermocouples may degrade with time. Small but continuing decreases or extreme variations in temperature or “no” temperature reading at all are signs that the thermocouple or thermocouples are degrading or open circuits have occurred. In this case, the thermocouple or thermocouples should be replaced in order to maintain accuracy in calibrating the burner. It is recommended that a record be kept for the amount of time the thermocouples are exposed to the oil burner’s flame.

NOTE 2: The Sonic burner is sensitive to proper alignment of the fuel nozzle. It is crucial that the fuel nozzle be aligned to the geometric center of the turbulator. A slight adjustment of the fuel tube between the stator and fuel nozzle may be required to obtain an even

temperature profile across the thermocouple rake. The center point of the nozzle where the fuel exits should not deviate more than 0.0625 inches from the geometric center of the turbulator exit plane when looking into the burner draft tube. This should be performed only after checking the burner for proper configuration.