

Chapter 23

Test Method to Determine the Flammability and Flame Propagation Characteristics of Thermal/Acoustic Insulation Materials

23.1 Scope

23.1.1 Applicability

Use this test method to evaluate the flammability and flame propagation characteristics of thermal/acoustic insulation when exposed to both a radiant heat source and a flame.

23.2 Definitions

23.2.1 Flame Propagation

The furthest distance of the propagation of visible flame towards the far end of the test specimen, measured from the midpoint of the ignition source flame. Measure this distance after initially applying the ignition source and before all flame on the test specimen is extinguished. The measurement is not a determination of burn length made after the test.

23.2.2 Radiant Heat Source

An electric panel with six 3-inch (76.2 mm) wide emitter strips.

23.2.3 Thermal/Acoustic Insulation

A material or system of materials used to provide thermal and/or acoustic protection. Examples include fiberglass or other batting material encapsulated by a film covering and foams.

23.2.4 Zero Point

The point of application of the pilot burner to the test specimen.

23.2.5 Refractory Board

A high-temperature, non-combustible, rigid insulation board with a maximum thermal conductivity of 0.694 Btu·in/hr·ft²·°F (0.10 W/m·K) at 500°F (260°C).

23.3 Apparatus

23.3.1 Radiant Panel Test Chamber

Conduct tests in a radiant panel test chamber (see figure 23-1). Place the test chamber under an exhaust hood to facilitate clearing the chamber of smoke after each test. The radiant panel test chamber must be an enclosure 55 inches (1397 mm) long by 19.5 inches (495 mm) deep by 28 (710 mm) to 30 inches (maximum) (762 mm) above the test specimen. Insulate the sides, ends, and top with 0.5-inch (13 mm) thick refractory board. On the front side, provide a 52 by 12-inch (1321 by 305 mm) draft-free, high-temperature, glass window for viewing the sample during testing. Place a door below the window to provide access to the movable specimen platform holder. The bottom of the test chamber must be a sliding steel platform that has provision for securing the test specimen holder in a fixed and level position. The chamber must have an internal chimney with exterior dimensions of 5.1 inches (129 mm) wide, by 16.2 inches (411 mm) deep by 13 inches (330 mm) high at the

opposite end of the chamber from the radiant energy source. The interior dimensions must be 4.5 inches (114 mm) wide by 15.6 inches (395 mm) deep. The chimney must extend to the top of the chamber (see figure 23-2).

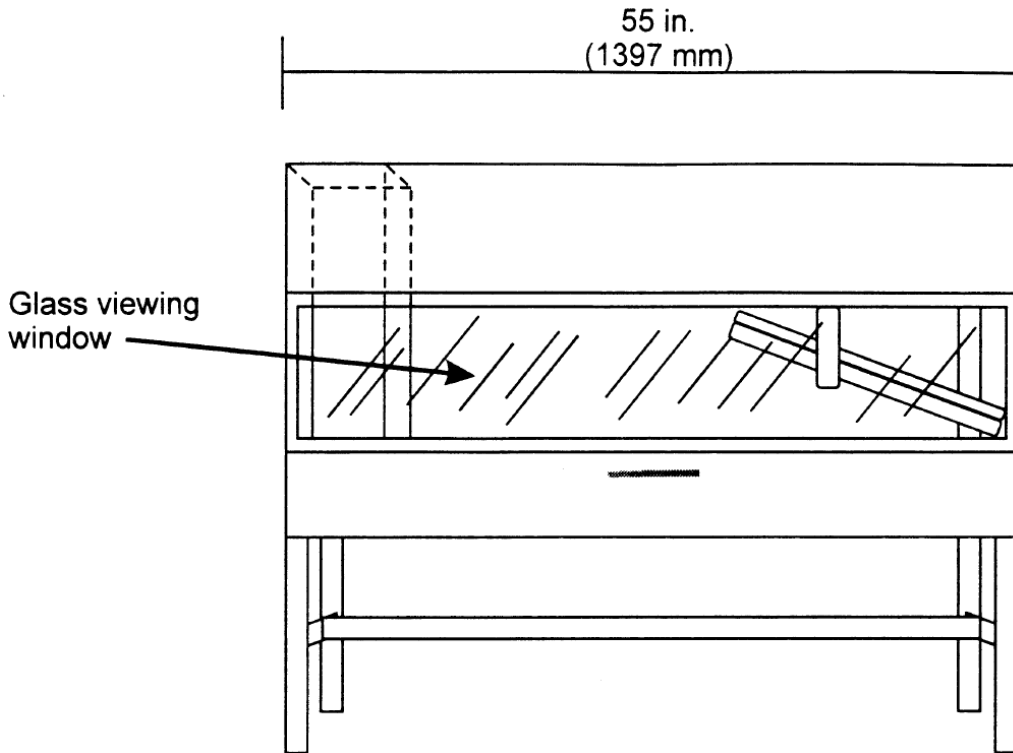

Figure 23-1. Radiant Panel Test Chamber

- 0.5 in. (13 mm) Refractory Board
- 16 gauge (0.0625 in.)(1.6 mm) aluminum sheet
- 0.125 in. (3.2 mm) angle iron

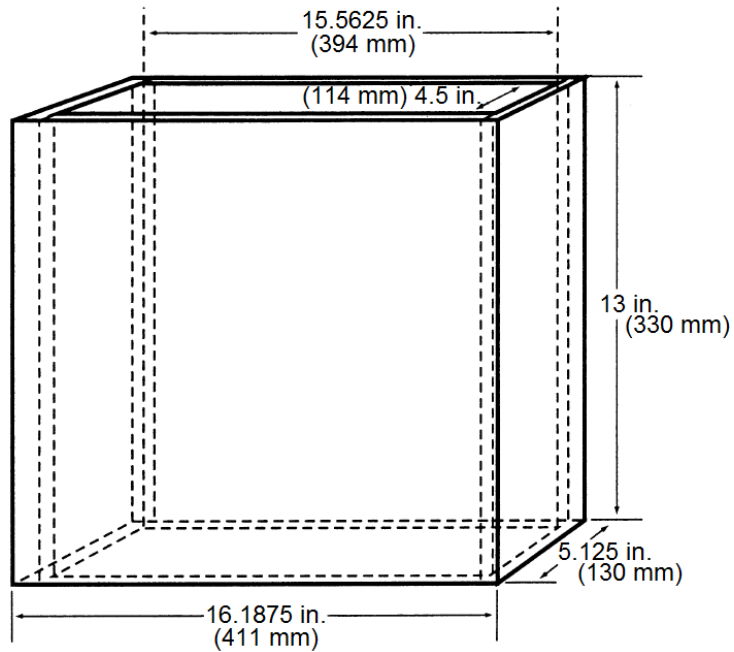

Figure 23-2. Internal Chimney

23.3.1.1 Draft Check

A draft check must be completed periodically if the test chamber is physically moved or if the exhaust system has been changed. Ensure that the chamber is draft free prior to turning on the power to the radiant heat source. To verify this, measure the airflow above the internal chimney with an anemometer device to ensure there is no airflow. Alternatively, an incense cone or other smoke-producing item can be placed on the sliding platform at the zero position with the platform drawer closed. Observe the smoke behavior. If the smoke rises vertically without any drift, it can be regarded as draft-free. If testing is performed with an exhaust hood running, the airflow check must be performed with the exhaust hood on.

NOTE: the sliding platform must have insulation boards covering the entire length of the platform for either method of draft checking.

23.3.2 Electric Radiant Heat Source

Mount the radiant heat energy source in a cast iron frame or equivalent. An electric panel must have six, 3-inch wide emitter strips. The emitter strips must be perpendicular to the length of the panel. The panel must have a radiation surface of 12.875 by 18.5 inches (327 by 470 mm). The panel must be rated at 7574 Watts and be capable of operating at temperatures up to 1300°F (704°C). Use a solid-state power controller and microprocessor-based controller to set the electric panel operating parameters.

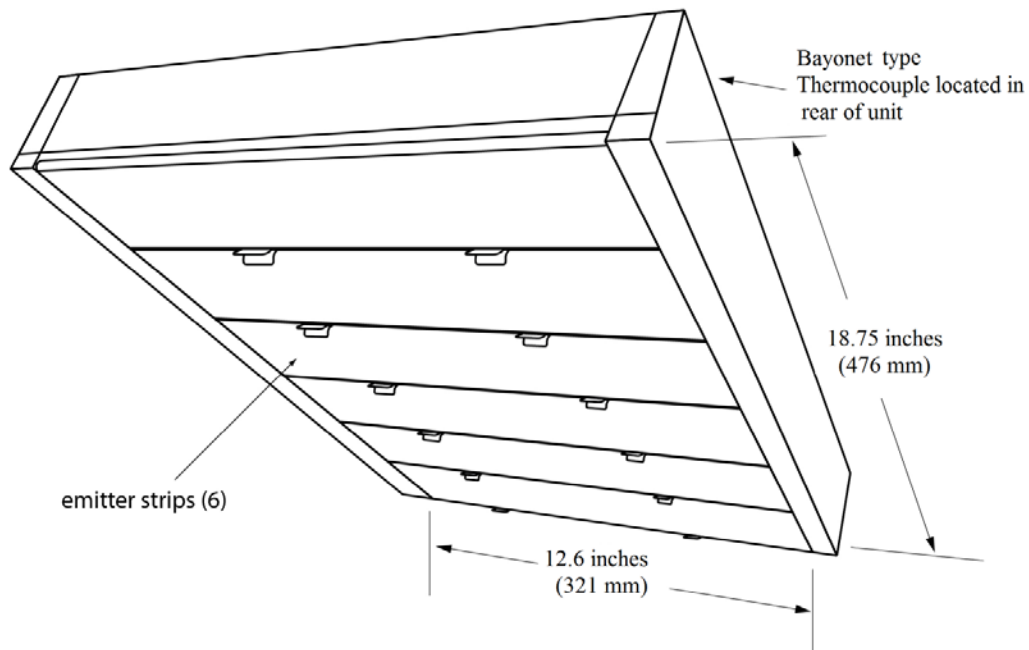

Figure 23-3. Electric Panel

23.3.2.1 Radiant Panel Placement

Mount the panel in the chamber at 30° to the horizontal specimen plane, and 7.5 inches above the zero point of the specimen.

23.3.3 Specimen Holding System

23.3.3.1 Sliding Platform

The sliding platform serves as the housing for test specimen placement. Brackets may be attached (via wing nuts) to the top lip of the platform in order to accommodate various thicknesses of test specimens. Place the test specimens on a sheet of refractory board either resting on the bottom lip of the sliding platform or on the base of the brackets. It may be necessary to use multiple sheets of material based on the thickness of the test specimen (to meet the sample height requirement). Typically, these noncombustible sheets of material are available in 0.25 inch (6 mm) or 0.5 inch (13 mm) thicknesses. See figure 23-4. A sliding platform that is deeper than the 2-inch (50.8mm) platform shown in figure 23-4 is also acceptable as long as the sample height requirement is met.

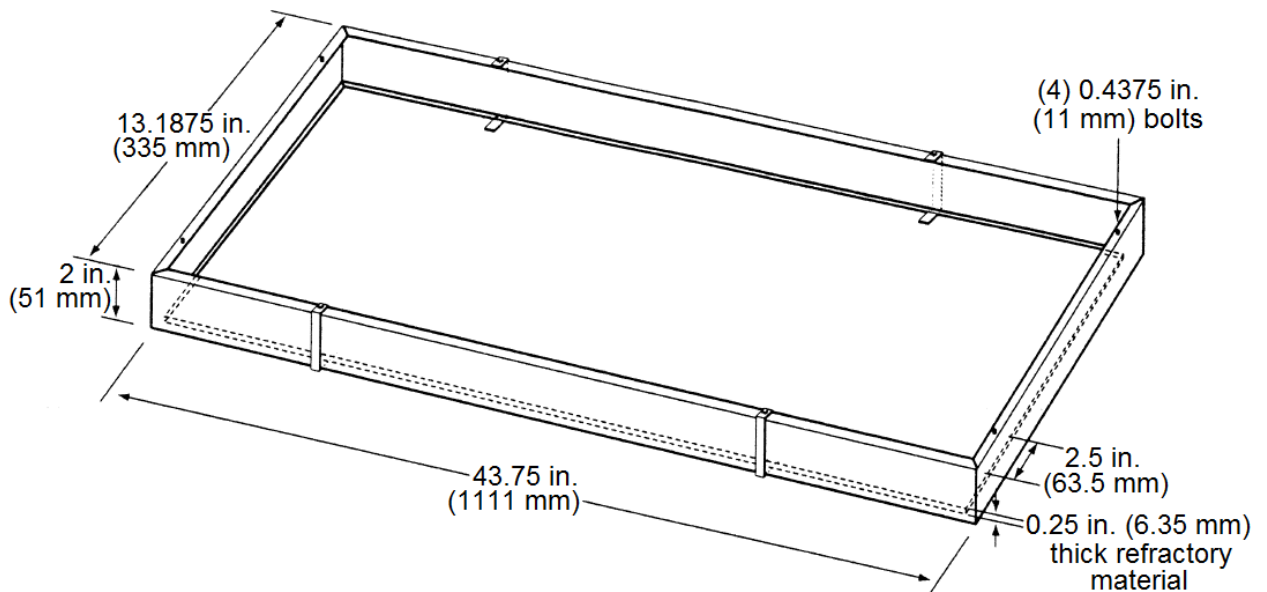

Figure 23-4. Sliding Platform

23.3.3.2 Specimen Heat Shield

Attach a ~~0.25~~ 0.5 inch (13 mm) piece of refractory board measuring 41.5 by 8.25 inches (1054 by 210 mm) to the back of the platform. This board serves as a heat retainer and protects the test specimen from excessive preheating. The height of this board must not impede the sliding platform movement (in and out of the test chamber). If the platform has been fabricated such that the back side of the platform is high enough to prevent excess preheating of the specimen when the sliding platform is out, a retainer board is not necessary.

23.3.3.3 Retaining Frame

Place the test specimen horizontally on the non-combustible board(s). Place a steel retaining/securing frame fabricated of mild steel, having a thickness of 0.125 inch (3.2 mm) and overall dimensions of 23 by 13.125 inches (584 by 333 mm) with a specimen opening of 19 by 10.75 inches (483 by 273 mm) over the test specimen. The front, back, and right portions of the top flange of the frame must rest on the top of the sliding platform, and the bottom flanges must pinch all four sides of the test specimen. The right bottom flange must be flush with the sliding platform. See figure 23-5.

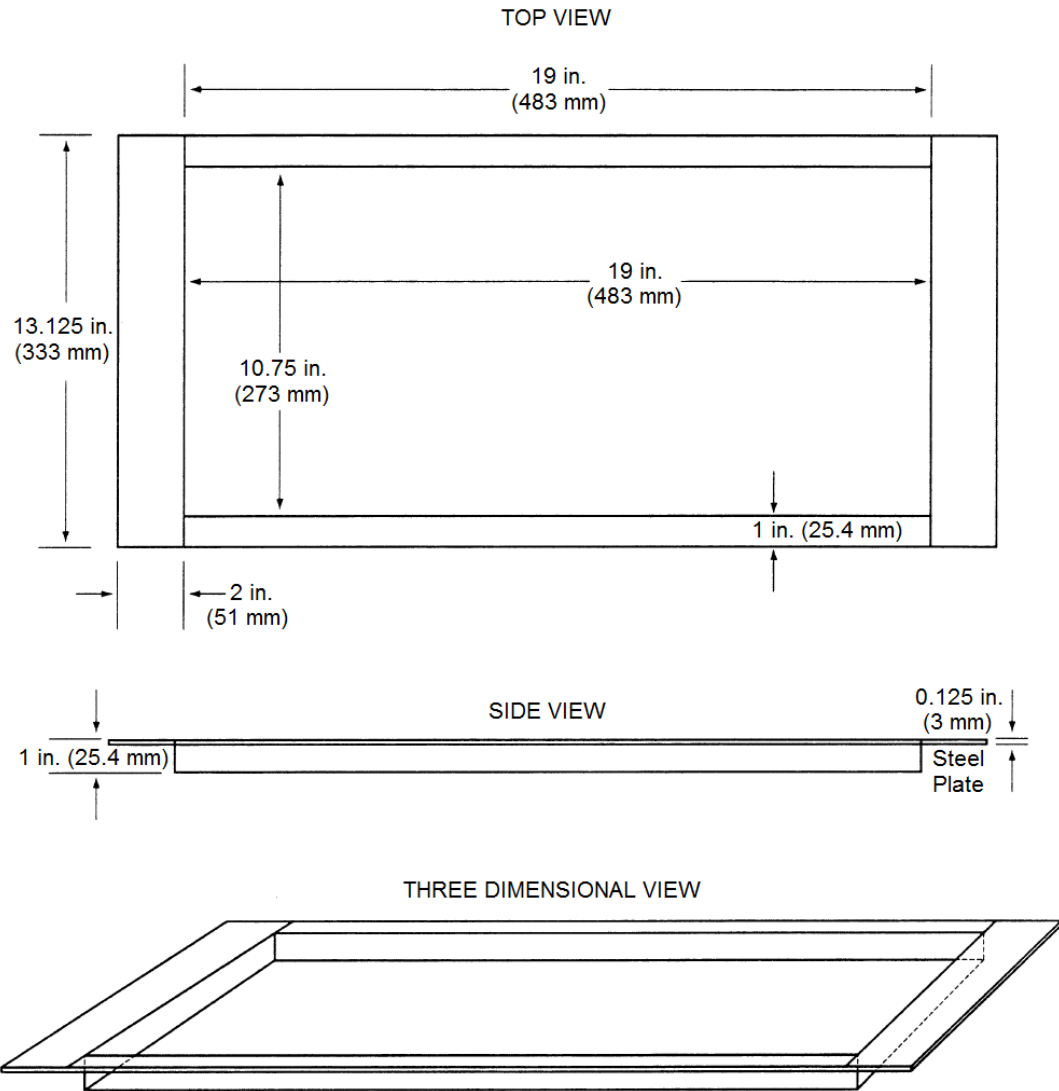

Figure 23-5. Retaining Frame (3 views)

23.3.4 Pilot Burner

The pilot burner used to ignite the specimen must be a propane Venturi torch with an axially symmetric burner tip and a propane supply tube with an orifice diameter of 0.006 inches (0.15 mm). The length of the burner tube must be 2.875 inches (71 mm). The propane flow must be adjusted via gas pressure through an in-line regulator to produce a blue inner cone length of 0.75 inch (19 mm). A 0.75 inch (19 mm) guide (such as a thin strip of metal) may be soldered to the top of the burner to aid in setting the flame height. The overall flame length must be approximately 5 inches long (127 mm). Provide a way to move the burner out of the ignition position so that the flame is horizontal and at least 2 inches (50 mm) above the specimen plane. See figure 23-6.

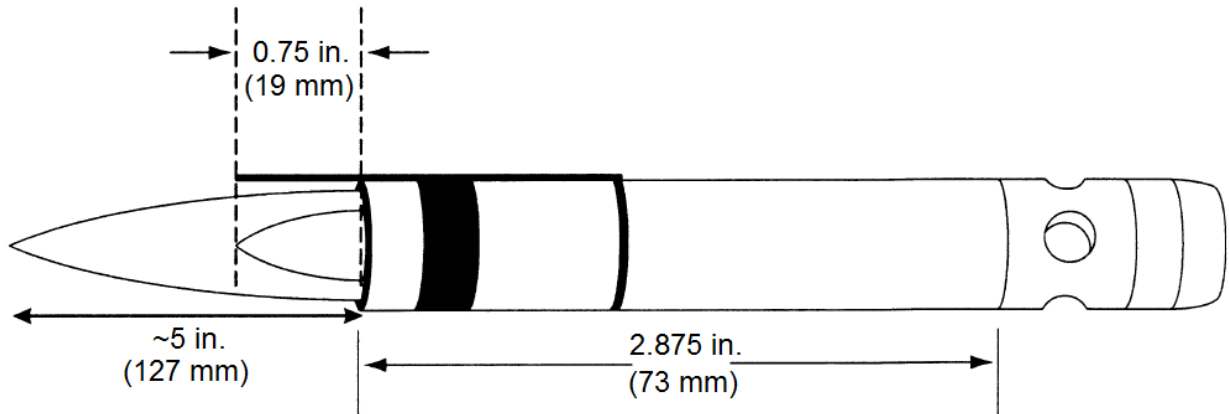

Figure 23-6. Propane Pilot Burner

23.3.5 Thermocouples

Install a 24 American Wire Gauge (AWG) Type K (Chromel-Alumel) thermocouple in the test chamber for temperature monitoring. Insert it into the chamber through a small hole drilled through the back of the chamber. Place the thermocouple so that it extends 11 inches (279 mm) out from the back of the chamber wall, 11.5 inches (292 mm) from the right side of the chamber wall, and is 2 inches (51 mm) below the radiant panel. The use of other thermocouples is optional.

23.3.6 Calorimeter

The calorimeter must be a one-inch cylindrical water-cooled, total heat flux density, foil type Gardon Gage that has a range of 0 to 4.4 BTU/ft²-second (0 to 5 Watts/cm²).

23.3.7 Calorimeter Calibration Specification and Procedure

23.3.7.1 Calorimeter Specification

23.3.7.1.1 Foil Diameter must be 0.25 ± 0.005 inches (6.35 ± 0.13 mm).

23.3.7.1.2 Foil material must be thermocouple grade Constantan.

23.3.7.1.3 Temperature measurement must be a Copper Constantan Thermocouple.

23.3.7.1.4 The copper center wire diameter must be 0.0005 inches (0.013 mm).

23.3.7.1.5 The entire face of the calorimeter must be lightly coated with “Black Velvet” paint having an emissivity of 96 or greater.

23.3.7.2 Calorimeter Calibration

23.3.7.2.1 The calibration method must be by comparison to a like standardized transducer.

23.3.7.2.2 The standardized transducer must meet the specifications given in section 23.3.6 of this chapter.

23.3.7.2.3 Calibrate the standard transducer against a primary standard traceable to the National Institute of Standards and Technology (NIST).

23.3.7.2.4 The method of transfer must be a heated graphite plate.

23.3.7.2.5 The graphite plate must be electrically heated, have a clear surface area on each side of the plate of at least 2 by 2 inches (51 by 51 mm), and be 0.125 ± 0.0625 inch thick (3.2 ± 1.6 mm).

23.3.7.2.6 Center the two transducers on opposite sides of the plates at equal distances from the plate.

23.3.7.2.7 The distance of the calorimeter to the plate must be no less than 0.0625 inches (1.6 mm), nor greater than 0.375 inches (9.5 mm).

23.3.7.2.8 The range used in calibration must be at least 0–3.5 BTU/ft²-second (0–3.9 Watts/cm²) and no greater than 0–5.7 BTU/ft²-second (0–6.4 Watts/cm²).

23.3.7.2.9 The recording device used must record the two transducers simultaneously or at least within 0.1 seconds of each other.

23.3.8 Calorimeter Fixture

With the sliding platform pulled out of the chamber, install the calorimeter holding frame and place a sheet of non-combustible material in the bottom of the sliding platform adjacent to the holding frame. This will prevent heat losses during calibration. The frame must be 13.125 inches (333 mm) deep (front to back) by 8 inches (203 mm) wide and must rest on the top of the sliding platform. It must be fabricated of 0.125 inch (3.2 mm) flat stock steel and have an opening that accommodates a 0.5 inch (12.7 mm) thick piece of refractory board, which is level with the top of the sliding platform. The board must have three 1-inch (25.4 mm) diameter holes drilled through the board for calorimeter insertion. The distance to the radiant panel surface from the centerline of the first hole (“zero” position) must be 7.5 ± 0.125 inches (191 ± 3 mm). The distance between the centerline of the first hole to the centerline of the second hole must be 2 inches (51 mm). It must also be the same distance from the centerline of the second hole to the centerline of the third hole. See figure 23-7. A calorimeter holding frame that differs in construction is acceptable as long as the height from the centerline of the first hole to the radiant panel and the distance between holes is the same as described in this paragraph.

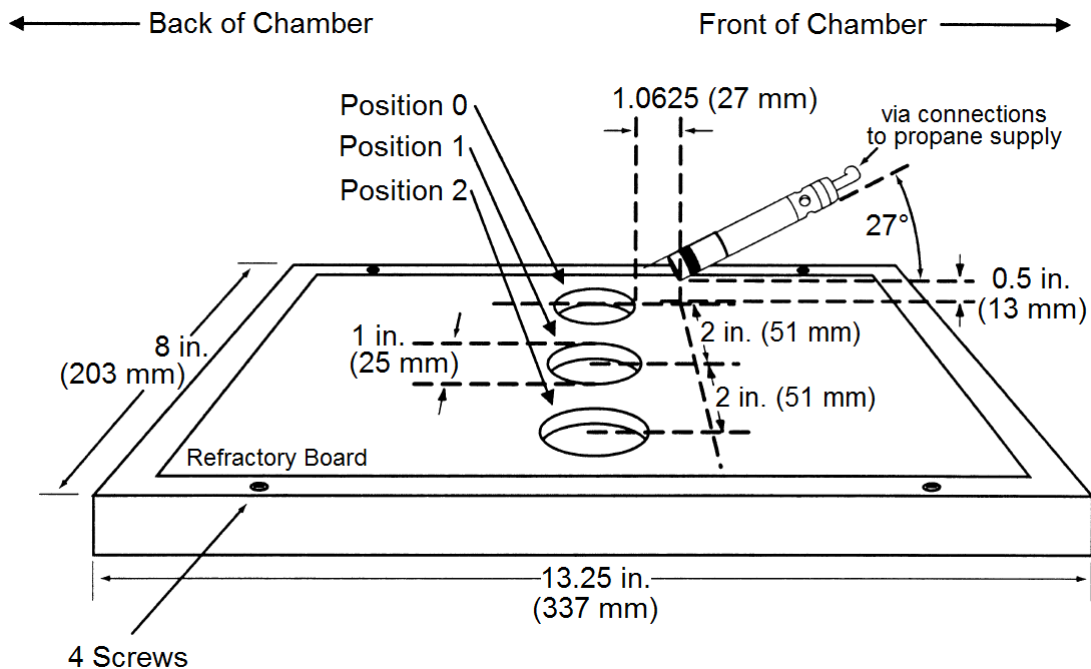

Figure 23-7. Calorimeter Holding Frame *Example*

23.3.9 Instrumentation

Provide a calibrated recording device with an appropriate range or a computerized data acquisition system to measure and record the outputs of the calorimeter and the thermocouple. The data acquisition system must be capable of recording the calorimeter output every second during calibration and calculate a 5-minute average of this data

23.3.10 Timing Device

Provide a stopwatch or other device, accurate to ± 1 second/hour, to measure the time of application of the pilot burner flame.

23.4 Test Specimens

23.4.1 Specimen Preparation

Prepare and test a minimum of three test specimens. If an oriented film cover material is used, prepare and test both the warp and fill directions.

23.4.2 Construction

Test specimens must include all materials used in construction of the insulation (including batting, film, scrim, tape etc.). Cut a piece of core material such as foam or fiberglass, and cut a piece of film cover material (if used) large enough to cover the core material. Heat sealing is the preferred method of preparing fiberglass samples, since they can be made without compressing the fiberglass (“box sample”). Cover materials that are not heat sealable may be stapled, sewn, or taped as long as the cover material is over-cut enough to be drawn down the sides without compressing the core material. The fastening means should be as continuous as possible along the length of the seams. The specimen thickness must be of the same thickness as installed in the airplane.

23.4.3 Specimen Dimensions

To facilitate proper placement of specimens in the sliding platform housing, cut non-rigid core materials, such as fiberglass, 12.5 inches (318mm) wide by 23 inches (584mm) long. Cut rigid materials, such as foam, 11.5 ± 0.25 inches ($292 \text{ mm} \pm 6 \text{ mm}$) wide by 23 inches (584mm) long in order to fit properly in the sliding platform housing and provide a flat, exposed surface equal to the opening in the housing.

23.4.4 Specimen Conditioning

Condition the test specimens at $70 \pm 5^\circ\text{F}$ ($21 \pm 2^\circ\text{C}$) and $55 \pm 10\%$ relative humidity, for a minimum of 24 hours prior to testing.

23.5 Apparatus Calibration

23.5.1 With the sliding platform out of the chamber, install the calorimeter holding frame. Push the platform back into the chamber and insert the calorimeter into the first hole (“zero” position). See figure 23-7. Close the bottom door located below the sliding platform. The distance from the centerline of the calorimeter to the radiant panel surface at this point must be 7.5 ± 0.125 inches ($191 \pm 3 \text{ mm}$). Prior to starting the radiant panel, ensure that the calorimeter face is clean and that there is water running through the calorimeter.

23.5.2 Turn on the panel. Adjust the set point on the temperature controller to achieve $1.5 \text{ BTU/ft}^2 \cdot \text{s} \pm 5\%$ ($1.7 \text{ Watts/cm}^2 \pm 5\%$) at the “zero” position. Allow the unit to reach steady state (this may take up to 1 hour) and

calculate a 5-minute average of the “zero position” heat flux. Adjust the set point as necessary to achieve the required heat flux. The pilot burner must be off and in the down position during this time.

23.5.3 After steady-state conditions have been reached, move the calorimeter 2 inches (51 mm) from the “zero” position (first hole) to position 1 and record the heat flux 5-minute average. Move the calorimeter to position 2 and record the heat flux 5-minute average. Allow enough time at each position for the calorimeter to stabilize. Table 23-1 depicts typical calibration values at the three positions $\pm 5\%$.

Position	BTU/ft ² -second	Watts/cm ²
“Zero Position”	1.5	1.7
Position 1	1.49 <u>to</u> 1.51	1.69 <u>to</u> 1.71
Position 2	1.43 <u>to</u> 1.44	1.62 <u>to</u> 1.63

Table 23-1. Typical Calibration Values

NOTE: Set the panel temperature controller to achieve a heat flux reading as close as possible to 1.5 BTU/ft²·s (1.7 Watts/cm²) at the zero position. With a correctly functioning panel, the values for positions 1 and 2 should fall very close to the numbers on table 23-1. The accuracy of the typical heat flux gauge in use is $\pm 3\%$. The accuracy of the full heat flux measurement system (heat flux gauge, data collection hardware, etc.) must be considered to ensure that the actual heat flux achieved is within $\pm 5\%$ of the prescribed values.

23.5.4 Open the bottom door; remove the calorimeter and holder fixture. Use caution as the fixture is very hot.

23.6 Test Procedure

23.6.1 If the chamber is located under an exhaust hood, the exhaust hood must be running throughout testing. Ignite the pilot burner. Ensure that it is at least 2 inches (51 mm) above the top of the platform. The burner must not contact the specimen until the test begins.

23.6.2 Place the test specimen in the sliding platform holder. Ensure that the test sample surface is level with the top of the platform. At “zero” point, the specimen surface must be 7.5 ± 0.125 inches (191 ± 3 mm) below the radiant panel.

23.6.3 Place the retaining/securing frame over the test specimen. It may be necessary (due to compression) to adjust the sample (up or down) in order to maintain the distance from the sample to the radiant panel (7.5 ± 0.125 inches (191 ± 3 mm) at “zero” position).

NOTE: With film/fiberglass assemblies, it is critical to make a slit in the film cover to purge any air inside. This allows the operator to maintain the proper test specimen position (level with the top of the platform) and to allow ventilation of gases during testing. A longitudinal slit, approximately 2 inches (51mm) in length, must be centered 3 ± 0.5 inches (76 ± 13 mm) from the left flange of the securing frame. A utility knife is acceptable for slitting the film cover.

NOTE: Foam samples tend to rise during testing, which can make flame propagation difficult to determine. It is acceptable to hold the foam sample in place with safety wire if the wire is positioned away from the propane igniter and does not affect the flame propagation.

23.6.4 Immediately push the sliding platform into the chamber and close the bottom door.

23.6.5 Bring the pilot burner flame into contact with the center of the specimen at the “zero” point and simultaneously start the timer. The pilot burner must be at a 27° angle with the sample and be approximately 0.5 inch (13 mm) above the sample. See figure 23-7. A stop, as shown in figure 23-8, allows the operator to position the burner correctly each time.

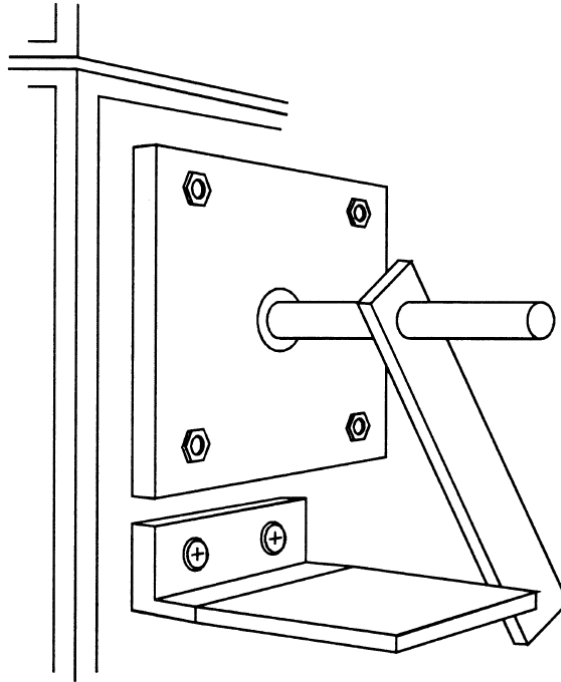

Figure 23-8. Propane Burner Stop

23.6.6 Leave the burner in position for 15 seconds and then remove to a position at least 2 inches (51 mm) above the specimen.

23.7 Report

23.7.1 Identify and describe the test specimen.

23.7.2 Report any shrinkage or melting of the test specimen.

23.7.3 Report the flame propagation distance. If this distance is less than 2 inches, report this as a pass (no measurement required).

23.7.4 Report the after-flame time.

23.8 Requirements

23.8.1 There must be no flame propagation beyond 2 inches (51 mm) to the left of the centerline of the pilot flame application.

23.8.2 The flame time after removal of the pilot burner may not exceed 3 seconds on any specimen.