

DOT/FAA/AR-02/51

Office of Aviation Research
Washington, D.C. 20591

Inerting a Boeing 747SP Center Wing Tank Scale Model With Nitrogen-Enriched Air

May 2002

Final Report

This document is available to the U.S. public
Through the National Technical Information
Service (NTIS), Springfield, Virginia 22161.



U.S. Department of Transportation
Federal Aviation Administration

NOTICE

This document is disseminated under the sponsorship of the U.S. Department of Transportation in the interest of information exchange. The United States Government assumes no liability for the contents or use thereof. The United States Government does not endorse products or manufacturers. Trade or manufacturer's names appear herein solely because they are considered essential to the objective of this report. This document does not constitute FAA certification policy. Consult your local FAA aircraft certification office as to its use.

This report is available at the Federal Aviation Administration William J. Hughes Technical Center's Full-Text Technical Reports page: actlibrary.tc.faa.gov in Adobe Acrobat portable document format (PDF).

1. Report No. DOT/FAA/AR-02/51		2. Government Accession No.		3. Recipient's Catalog No.	
4. Title and Subtitle INERTING A BOEING 747SP CENTER WING TANK SCALE MODEL WITH NITROGEN- ENRICHED AIR				5. Report Date May 2002	
				6. Performing Organization Code AAR-440	
7. Author(s) William M. Cavage and Ole Kils				8. Performing Organization Report No. DOT/FAA/AR-02/51	
9. Performing Organization Name and Address Federal Aviation Administration William J. Hughes Technical Center Airport and Aircraft Safety Research and Development Division Fire Safety Branch Atlantic City International Airport, NJ 08405				10. Work Unit No. (TRAIS)	
				11. Contract or Grant No.	
12. Sponsoring Agency Name and Address U.S. Department of Transportation Federal Aviation Administration Office of Aviation Research Washington, DC 20591				13. Type of Report and Period Covered Final Report	
				14. Sponsoring Agency Code ANM-112	
15. Supplementary Notes Ole Kils is presently an undergraduate student at the College of Engineering at Rutgers University. He was the primary investigator for the project under the tutelage of William M Cavage.					
16. Abstract Tests were performed in a 0.24 scale model of a Boeing 747SP center wing tank to validate the existing assumptions for inerting complex geometric spaces, which were developed from previous experiments, and to facilitate design of an efficient, cost-effective inerting gas deposit system for full-scale, ground-based inerting testing. The model was equipped with a variable nitrogen-enriched air distribution system, thermocouples, and oxygen analyzers that were monitored and recorded continuously by a data acquisition system during each test. The model was inerted in different configurations with different flow rates and bay distributions. The collected data was nondimensionalized in terms flow rate and tank size to allow for comparisons between tests. Experiments in the tank verified that the volumetric tank exchange established from research with a simple box-style tank can be achieved in a more complex compartmentalized tank. It also indicated that the same volumetric tank exchange could be obtained with less gas distribution (less complex distribution system) and that modification of the venting configuration to eliminate cross-venting would improve the efficiency of the inerting process. Tests showed that the most efficient method of inerting the tank was to deposit all the nitrogen-enriched air in a single location, allowing for a lightweight, easily installed deposit system for an operational aircraft. Data from full-scale testing compared well with scale tank data illustrating that low cost, small-scale test articles can be an effective tool for developing inert gas distribution systems.					
17. Key Words Nitrogen enriched air, Ullage washing, Volume flow rate, Fuel tank inerting, Oxygen concentration, Volumetric tank exchange			18. Distribution Statement This Document is available to the public through the National Technical Information Service (NTIS), Springfield, Virginia 22161		
19. Security Classif. (of this report) Unclassified		20. Security Classif. (of this page) Unclassified		21. No. of Pages 44	22. Price

TABLE OF CONTENTS

	Page
EXECUTIVE SUMMARY	vii
1. INTRODUCTION	1
1.1 Background	1
1.1.1 Ground-Based Inerting	1
1.1.2 Previous Research	2
1.1.3 Commercial Transport Fuel Tanks	2
1.2 Scope	2
2. EQUIPMENT AND PROCEDURES	3
2.1 Equipment	3
2.1.1 Test Specimen	3
2.1.1.1 Fuel Tank Model	3
2.1.1.2 Instrumentation	5
2.1.2 Tank Inerting	7
2.1.2.1 Nitrogen-Enriched Air Generator	7
2.1.2.2 Nitrogen-Enriched Air Distributing Manifold	7
2.1.3 Data Acquisition System	9
2.2 Test Procedures	9
2.2.1 Cross-Venting Configuration	10
2.2.2 Blocked-Vent Configuration	11
3. ANALYSIS	12
3.1 Data Calculations	12
3.1.1 Calculations to Determine Testing Parameters	12
3.1.2 Calculations to Reduce Data	12
3.2 Inerting Solutions	13
3.2.1 Exact Solution	13

3.2.2	Empirical Solution	13
4.	DISCUSSION OF RESULTS	14
4.1	Cross-Venting Configuration	14
4.1.1	Balanced Data	14
4.1.2	Uneven Distribution Testing	16
4.2	Blocked-Vent Configuration	17
4.2.1	Uneven Distribution	17
4.2.2	Equalization of Bay Oxygen Concentration	20
4.2.3	Sensitivity of Optimal Case	20
4.2.3.1	Sensitivity to Flow Rate	22
4.2.3.2	Sensitivity to NEA Percentage	23
4.2.4	Comparison With Full-Scale Test Article	24
5.	SUMMARY OF FINDINGS	26
6.	REFERENCES	27
APPENDIX A—FIGURES AND TABLES USED TO CONSTRUCT MODEL OF A BOEING 747SP CENTER WING TANK		

LIST OF FIGURES

Figure		Page
1	Off-Axis View of a 747 Center Wing Tank	3
2	Top Diagram of a Boeing 747SP Center Wing Tank With Bay Number Convention	4
3	Center Wing Tank With Top Removed	5
4	Block Diagram of Oxygen Sample System	6
5	Industrial NEA Generator	8
6	Block Diagram of NEA Deposit Manifold	8
7	NEA Deposit Manifold Control Panel	9
8	Bay Oxygen Concentration Data for the Balanced Inerting Test in the Cross-Vented Configuration	15
9	Weighted Average Tank Oxygen Concentration Data for the Balanced Deposit Method for 93%, 95%, and 98% NEA	15
10	Comparison of Previous Data With Weighted Average Tank Oxygen Concentration for the Balanced Deposit Method	16
11	Bay Oxygen Concentration Data for a Typical Uneven Distribution Inerting Test	17
12	Weighted Average Tank Oxygen Concentration for Several Uneven Distribution Tests With Balanced Deposit Data	18
13	Bay Oxygen Concentration Data for the Balanced Inerting Test With One Vent Blocked	18
14	Bay Oxygen Concentration Data for a Typical Uneven Distribution Test With One Vent Blocked	19
15	Weighted Average Tank Oxygen Concentration for Uneven Distribution Methods With Balanced Deposit Method Data	20
16	Bay Oxygen Concentration Illustrating Diffusion After Typical Uneven Distribution Test	21
17	Repeat of Optimal Deposit Case After Tank Maintenance and Modification	22

18	Comparison of Average Tank Oxygen Concentration for the Optimal Distribution Methods for Different Flow Rates	23
19	Comparison of Average Tank Oxygen Concentration for the Optimal Distribution Methods for Different NEA Percentages	24
20	Comparison of Bay Inerting Data for Both the Scale Model and the Full-Scale Test Article	25
21	Comparison of Tank Average Oxygen Concentration for Both the Scale Model and the Full-Scale Test Article	26

LIST OF TABLES

Table		Page
1	Table of Bay Volumes for the 747SP CWT	4
2	Table of Inerting Tests for the Cross-Vented Configuration	10
3	Table of Inerting Tests for the Blocked-Vent Configuration	11

EXECUTIVE SUMMARY

Significant emphasis has been placed on fuel tank safety since the TWA flight 800 accident in July 1996. One proposed method of reducing the flammability of fuel tanks is fuel tank inerting, which is commonly used by the military. A 1998 Aviation Rulemaking Advisory Committee working group has stated the most potentially cost-effective method of fuel tank flammability reduction is ground-based inerting (GBI). Ground-based inerting is defined as inerting fuel tanks during ground operations, eliminating the need to install nitrogen generating equipment on airplanes. GBI could provide significant protection from ground operations through cruise portions of commercial airplane operations, depending upon fuel load and ground duration. Significant research and testing has been performed to quantify the ability of nitrogen or nitrogen-enriched air (NEA) to inert a fuel tank, but very little data is available that illustrates the best method of inerting complex geometric spaces, such as most commercial transport fuel tanks. Flight tests on a Boeing 737-700 center wing tank (CWT), with a complex distribution manifold, indicated the process would be less efficient than theoretically determined. These tests also illustrated a need to eliminate cross-venting of the CWT to prevent air from entering the tank during some ground and flight operations.

A 0.24 scale model of a Boeing 747SP center wing tank was constructed and equipped with a variable inerting gas distribution system, thermocouples, and oxygen analyzers at the William J. Hughes Technical Center, Atlantic City International Airport, NJ. The tank was inerted with NEA and the conditions in each bay were monitored and recorded continuously by a data acquisition system. This scale tank was easily modified to experiment with different flow rates, bays distribution methods, and venting configurations. The objective of these experiments was to validate existing assumptions about inerting complex geometric spaces and promote the efficiency of the process by reducing the amount of NEA required to inert an empty tank while using a distributing configuration with a simple and easily installed manifold. The amount of NEA required to inert the tank can be expressed in terms of the volume of NEA deposited divided by the tank volume, which is known as the volumetric tank exchange (VTE). A series of tests were performed to establish a VTE for different inerting configurations with various venting configurations. The collected data was nondimensionalized in terms of flow rate and tank size to allow for comparisons between tests.

Experiments in the tank verified that the VTE established from research with a simple box-style tank can be achieved in a more complex structure. It also indicated that modification of the venting configuration would positively impact the inerting process. Experimentation with different distributions into the tank bays showed that a volumetrically balanced inerting of all the bays, requiring a rather complex manifold, would require a VTE of 1.6 to inert the tank. This is consistent with previous experiments in simple rectangular tanks. However, a focused flow of NEA into one bay, the furthest away from the vent exits, will cause less bay-to-bay mixing and allow more air to vent from the tank before inert gas begins to mix into the exit bays. This improves the efficiency of the inerting process and allows for the tank to reach the target oxygen concentration of 8 percent with a VTE of approximately 1.3. The test data compares well with data acquired from the full-scale test article illustrating the potential to develop better gas distribution methodologies using inexpensive, scale test articles.

1. INTRODUCTION.

1.1 BACKGROUND.

Significant emphasis has been placed on fuel tank safety since the TWA flight 800 accident in July 1996. Since the accident, the Federal Aviation Administration (FAA) has issued numerous Airworthiness Directives, enacted a comprehensive regulation to correct potential ignition sources in fuel tanks, and conducted research into methods that could eliminate or significantly reduce the exposure of transport airplanes to flammable vapors. The latter has been in response to a new FAA policy that strives to eliminate or reduce the presence or consequences of flammable fuel tank vapors. This has included fuel tank inerting, which is commonly used by the military. However, the weight, resource requirements, and relatively low dispatch reliability have indicated that military fuel tank inerting systems would not be practical for application to transport airplanes.

Recently, a fuel tank inerting working group was formed by the Aviation Rulemaking Advisory Committee (ARAC) in response to a recent task assigned by the FAA to recommend a proposed rule that would require a reduction in flammability of some or all commercial transport fuel tanks. A previous ARAC working group has stated that a potentially cost-effective method of fuel tank flammability reduction is ground-based inerting (GBI) [1]. The new working group was charged with examining fuel tank inerting methods to reduce or eliminate the flammability of all or some fuel tanks in the commercial transport fleet, while developing regulatory text as well as determining cost and benefit of the proposed rule change. One focus of the working group was to determine the amount of inerting gas needed to inert a commercial transport category airplane.

1.1.1 Ground-Based Inerting.

Ground-based inerting or GBI is defined as inerting fuel tanks during ground operations, eliminating the need for inert gas storage or generating equipment onboard the aircraft. This inerting is believed to provide extended protection into flight, depending on the fuel load, ground time, and flight profile as the tanks cool and exposure to flammable vapors is reduced. Although significant research and testing has been performed to quantify the ability of nitrogen or nitrogen-enriched air (NEA) to inert a commercial transport fuel tank, the efficiency and cost-effectiveness of the process could be improved to allow for GBI to be more economically feasible.

Whether supplied by a ground source or generated onboard the aircraft, inerting would be accomplished by ullage washing, which is a process that displaces the air in the fuel tank empty space, also known as ullage, with nitrogen gas or NEA. NEA is a term used to describe low-purity nitrogen (90%-98% pure), generally generated with a gas separation process. Air separation modules, such as hollow-fiber membranes, are becoming more commonly used for inert gas generation and have recently begun to be applied in the aviation industry, particularly in the military sector. Ullage washing would be accomplished by providing the nitrogen or NEA to a supply line that feeds a fuel tank inerting manifold, which distributes the NEA in a manner that requires the least amount of NEA while still having the least amount of complexity.

1.1.2 Previous Research.

Previous research has focused on the ability to inert an empty fuel tank by ullage washing with NEA of different oxygen percentages. The target oxygen concentration for an inert ullage for these studies was 8 percent oxygen by volume. This allows for some dispersion of nitrogen during ground operations, taxi, and takeoff, while still maintaining ullage oxygen concentrations below the critical level, generally accepted to be between 10 and 12 percent by volume. Lab testing has shown that NEA 95 (nitrogen with 5% oxygen concentration) can inert an empty, rectangular, single-bay, fuel tank test article by ullage washing with 1.5 times the volume of the tank (volumetric tank exchange). This means passing 1.5 times the tank volume of NEA 95 through the ullage will yield an ullage oxygen concentration of 8% by volume [2].

A smaller rectangular tank (17 cubic ft) was inerted using NEA 95 at similar and significantly greater relative flow rates as part of a series of tests examining the effects of fuel on an inert ullage space. Results showed that the ullage could be consistently inerted to 8 percent with a volumetric tank exchange of 1.6.

A distribution manifold was designed and installed in a Boeing 737-700 flight test aircraft to uniformly distribute NEA gas into the center wing fuel tank bays during ground inerting. The manifold inerted the fuel tank with 1.7 to 1.8 volumetric tank exchanges [3]. This discrepancy was believed to be due to inefficiency of the deposit manifold. However, very little data is available on inerting compartmentalized tanks to validate that the 1.5 to 1.6 volumetric tank exchange value obtained in a rectangular tank applies to the more complex geometry of a commercial transport fuel tank.

1.1.3 Commercial Transport Fuel Tanks.

Fuel tanks in commercial transport airplanes are generally sealed geometric structures in the wing or tail of the aircraft. This is generally the volume between the front and rear spar within the upper and lower wing surface. These tanks are vented to the aircraft exterior to ensure that ambient pressure is maintained within the tank. Venting is accomplished by a tube in each tank with a float valve at the opening that attaches to a large sealed stringer within the wing that travels the length of the wing. This vent stringer terminates at a small overflow compartment at the end of the wing called the surge/vent tank. This tank vents to the outside through an aerodynamic opening.

Many commercial transport aircraft have an extra wing fuel tank contained partially or fully within the aircraft fuselage. These tanks are generally referred to as center wing tanks (CWTs). Most commercial transport aircraft have air cycle machines below these CWTs that condition hot, ducted air from the engines and reject heat during operation [4]. These tanks have been identified in the 1998 ARAC report as potentially more flammable and statistically more susceptible to explosions [1].

1.2 SCOPE.

To study the ability of NEA to inert complex geometric spaces, a scale model of a Boeing 747SP CWT was constructed from plywood. This fuel tank model was used to validate existing

assumptions for inerting fuel tanks developed from inerting rectangular, single-compartment tanks. The model was also used to evaluate different ullage-washing methods in an attempt to determine the simplest and most efficient approach to fuel tank inerting. The scale test article allowed for rapid evaluation of different flow deposit methodologies and venting configurations to determine the optimal inerting manifold for a Boeing 747SP. All testing was performed in the Aircraft Components Fire Test Facility at the FAA William J. Hughes Technical Center located at the Atlantic City International Airport in New Jersey.

2. EQUIPMENT AND PROCEDURES.

2.1 EQUIPMENT.

The testing apparatus for this project consisted of a 0.24 scale 747SP CWT model, an NEA generator with variable distributing manifold, oxygen analyzers and thermocouples in each bay, and a computer-based data acquisition system.

2.1.1 Test Specimen.

2.1.1.1 Fuel Tank Model.

The tank model was constructed from plywood using drawings from an National Transportation Safety Board (NTSB) report detailing work done on scale modeling of a 747 CWT [5]. Figure 1 gives an off-axis view of the CWT of a Boeing 747. The tank was built to 24% length scale (1.38% volume). Each spanwise beam, spar, and partial rib was also scaled as well, with all penetration holes being scaled in terms of relative hole area. The forward most bay between the front spar and spanwise beam 3 is a dry bay on the 747SP. That bay was sealed to prevent significant entry of NEA, reducing the possibility of flow patterns that differ greatly from the actual aircraft. Figure 2 gives a top diagram of the 747SP tank bays with the spanwise beams and spars labeled. This diagram gives the numbering convention for the bays to be used in this report. Appendix A contains the drawings from the NTSB report used to make to the scale model.

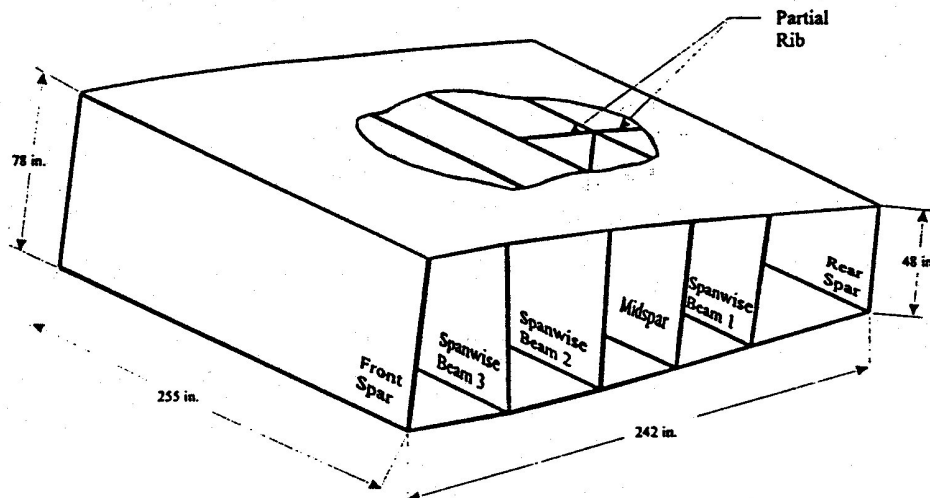

FIGURE 1. OFF-AXIS VIEW OF A 747 CENTER WING TANK

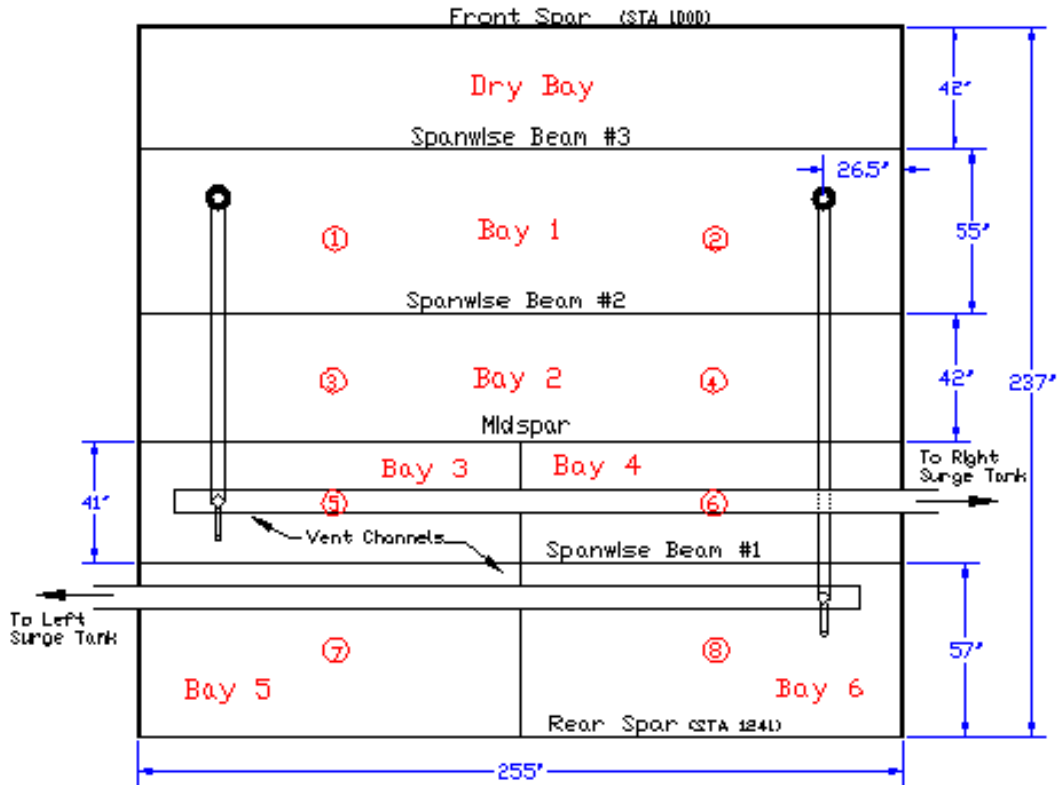

FIGURE 2. TOP DIAGRAM OF A BOEING 747SP CENTER WING TANK WITH BAY NUMBER CONVENTION

Table 1 gives the full-scale calculated and scaled volumes of each bay. These numbers are compared with the volumes of each bay determined in reference 5. The bay volumes were calculated with the side-view drawing of the CWT from appendix A (figure A-1). The dimensions from the drawing were used to approximate several basic geometric shapes within each bay. The areas of these shapes were then calculated and added to obtain the cross-sectional area of each bay, which was then, in-turn, multiplied by the tank width to get the volume of each bay. With this data, the relative percentage of volume of each bay could be calculated.

TABLE 1. TABLE OF BAY VOLUMES FOR THE 747SP CWT

Bay	Calculated Volume (ft ³)	Scaled Value	Percentage of Tank	NTSB Rpt Volume (ft ³)	Percentage Volume
0(dry)	546.1	7.549	n/a	536.7	n/a
1	577.7	7.986	31.2%	543.9	30.7%
2	421.1	5.823	22.7%	392.0	22.2%
3	188.2	2.602	10.1%	196.0	11.1%
4	188.2	2.602	10.1%	196.0	11.1%
5	239.6	3.312	12.9%	220.7	12.5%
6	239.6	3.312	12.9%	220.7	12.5%
Total	1854.4	25.637	100%	1769.3	100%

To duplicate the venting system of a 747SP, a scale vent channel was constructed from a piece of 1- x 1/4-inch aluminum C-Channel affixed to a strip of 1/4-inch plywood mounted along the top of the tank. One vent channel travels along the top of bays 3 and 4, while the other travels along the top of bays 5 and 6. These channels vent crosswise to the exterior of the tank so that the vent channel plumbed on the right side of the tank (bays 5 and 6) is vented to the left side of the aircraft and vice-versa. Each channel is plumbed to a piece of 1-inch PVC tubing that travels forward perpendicular to the spanwise beams and spars across the bays. A piece of a 1/2-inch PVC tubing travels aft within the bay. The vent channel is used to simulate the climb/dive-venting configuration of the aircraft.

To facilitate maintenance and modification of the tank, the entire top of the tank is removable. It is held in place by 30 buckles and is sealed with weather stripping and silicon caulking. Figure 3 shows the tank model with the lid removed to illustrate tank construction and orientation.

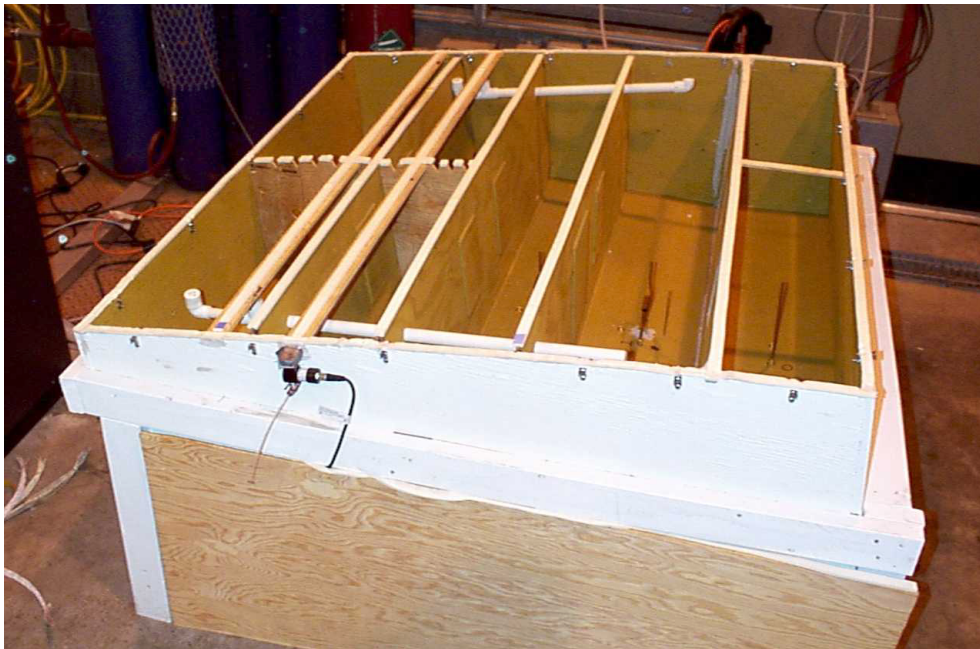

FIGURE 3. CENTER WING TANK WITH TOP REMOVED

2.1.1.2 Instrumentation.

To monitor conditions inside the tank, each bay was fitted with a thermocouple and an oxygen sample port both at the approximate geometrical center of each of the six bays.

2.1.1.2.1 Oxygen Analysis.

The oxygen analyzers were flow-through oxygen sensors that used a galvanic cell to determine the partial pressure of oxygen and presented a calibrated volumetric oxygen concentration based on sample pressure. The oxygen sensor was remote to the analyzer and attached to the analyzer via a cable. This allowed for the sensor to be mounted directly beneath the model. The analyzers were mounted in groups of four on a mounting plate in a standard 19-inch rack and

provided a 0 to 1 VDC output for the data acquisition system. The analyzers had a readout that indicated 0% to 25% oxygen concentration.

The sensor gas sample system used for the experiment was set up in a unique manner to decrease the response time of the oxygen analyzers. The sample system was plumbed to have the pump draft the gas sample from each bay through the sensor, through the pump, through the needle valve and flow meter, and then back to the tank. This is contrary to the traditional method of drafting a sample from the environment, pumping it to pressure, regulating the sample by passing it through a needle valve and flow meter, then through the sensor, and back to the tank. Although the latter system gives a very stable analysis environment with a slow 20-40 second response time, the method employed for this testing allowed for much faster response times (3-5 seconds). Changes in the lab temperature and pressure could effect calibration, so care was taken to keep the lab environment as stable as possible and to check the calibration frequently.

The oxygen sample was taken from the center of each bay via a 1/4-inch tube attached to a 1/4-inch bulkhead compression fitting that passed through the bottom of the tank and connected to the oxygen sensor. The sample was then reduced to a 1/8-inch nylon tube and pumped with a diaphragm pump. The sample then passed through a needle valve and flow meter and was then returned to the tank. Figure 4 gives a diagram of the oxygen sample system.

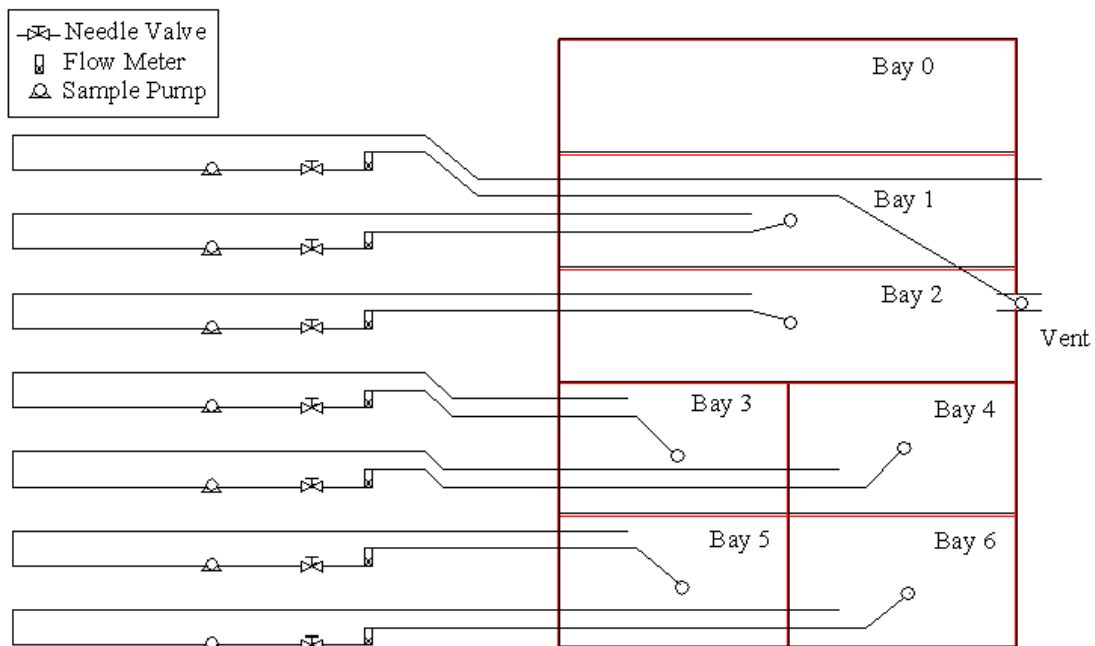

FIGURE 4. BLOCK DIAGRAM OF OXYGEN SAMPLE SYSTEM

Upscale calibration was frequently performed using 8-percent NEA. This was accomplished by washing NEA 92% through the ullage for approximately four to five volume changes. Upscale calibration allows for more accurate measurement of lower oxygen concentrations, while sacrificing accuracy at or near full-scale. To maintain acceptable accuracy in the 15 to 20

percent oxygen range, correction factors were developed for each analyzer that were applied to the data during reduction. These correction factors allowed for accurate data throughout the measurement range (5 to 20.9-percent oxygen concentration) while maintaining a high degree of certainty of when the tank bay in question reached 8 percent oxygen concentration.

2.1.1.2.2 Temperature.

To detect changes in temperature during the inerting process, the test article was instrumented with 7 “K” type thermocouples. Thermocouples were located at the center of each bay, and one thermocouple was located in the NEA gas stream to monitor temperature changes during a test.

2.1.2 Tank Inerting.

2.1.2.1 Nitrogen-Enriched Air Generator.

To provide inerting gas for the experiments, a hollow-fiber membrane (HFM) NEA generator was used. HFM technology is a cost-effective and efficient method of generating relatively large quantities of NEA. HFM gas separation modules are generally made from spun polymeric fibers manufactured with a structural center support that are bundled together in tubes with each end potted. The tube allows for the potted end to be pressurized, the product end to be plumbed, and contains a vent hole for the waste gas (permeate) to exit [2].

The industrial gas generator used to provide NEA to the test article was a general purpose, off-the-shelf HFM gas separator. The unit required 10 amps of 120 Volts and was supplied with air by a large industrial air compressor in the facility. The unit came equipped with an oxygen analyzer that allows for the adjustment of the purity of the NEA gas (oxygen concentration), using the purity control valve, to values between 13-percent oxygen by volume (NEA 87 percent) and less than 1-percent oxygen by volume (NEA 99 + percent). The oxygen analyzer was calibrated with air and checked with 8% calibration gas to ensure accurate oxygen concentration readings in the model. The unit was modified with a bypass valve to regulate flow volume and NEA purity independently. The unit was capable of generating approximately 25 cubic feet per minute (CFM) of 95% NEA. Figure 5 shows the NEA generator used to supply the inerting gas for the experiments.

2.1.2.2 Nitrogen-Enriched Air Distributing Manifold.

The tank model was equipped with an external inerting manifold that allowed for variable distribution of NEA to any and all bays at different flow rates, while monitoring the back pressure and flow rates of the system as a whole and of each individual bay. The NEA generator outflow was plumbed to a master 50-400 cubic feet per hour (CFH) flow meter with a 0-160 psi backpressure gage. Controlling the flow rates into each individual bay were 12 flow meters, 2 meters depositing in parallel into a single NEA deposit line for each of the six bays. One flow meter was a 50 to 400 CFH coarse adjustment and the other a 5 to 50 CFH fine adjustment with each bay deposit having a 0 to 15 psi back-pressure gage. Figure 6 gives a block diagram of the NEA deposit manifold with flow meters and backpressure gages. Figure 7 shows the NEA deposit manifold control panel.



FIGURE 5. INDUSTRIAL NEA GENERATOR

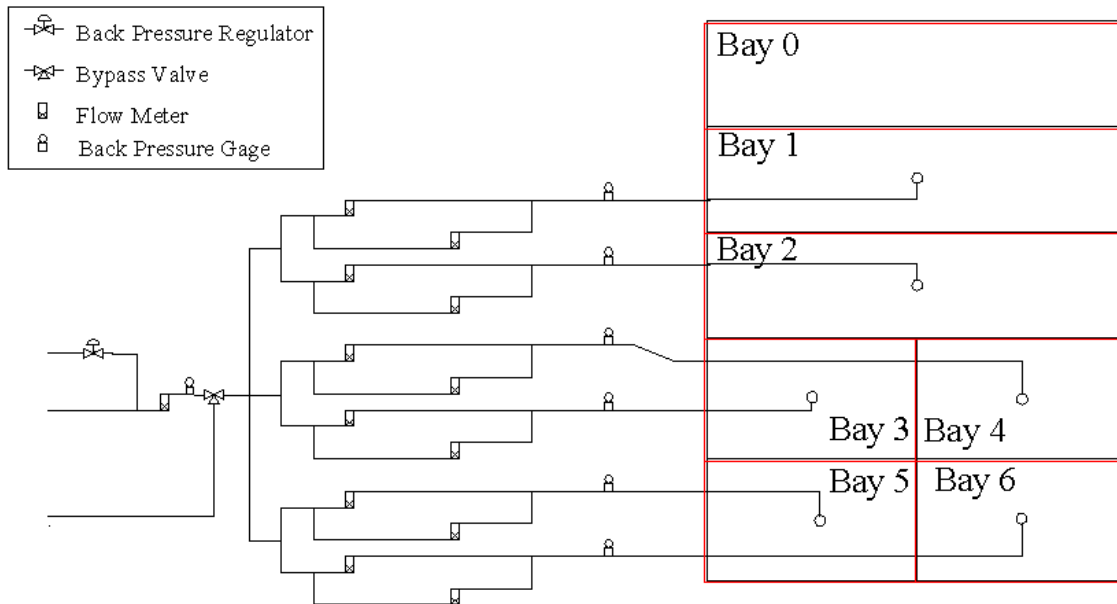

FIGURE 6. BLOCK DIAGRAM OF NEA DEPOSIT MANIFOLD



FIGURE 7. NEA DEPOSIT MANIFOLD CONTROL PANEL

Inside the tank, the NEA could be directed in any desired direction from the approximate geometrical center of each bay by interchangeable 1/2-inch copper pipe elbows. Shop air was distributed into the tank to give a fixed starting point for each test (20.9% oxygen by volume).

2.1.3 Data Acquisition System.

A computer data acquisition system continuously monitored and recorded the conditions inside the tank during each test. Data acquisition was accomplished via two A/D boards configured in a standard desktop PC. A computer program was written to acquire the signals and convert each to engineering units with a specified calibration file. Each test was saved as an ASCII file and imported into a spreadsheet where the data was manipulated and plotted.

2.2 TEST PROCEDURES.

Tests were performed in the Aircraft Components Fire Test Facility at the William J. Hughes Technical Center located at the Atlantic City International Airport in New Jersey. The testing apparatus was inside a climate-controlled, fire-proof test cell, which kept the conditions relatively stable, allowing for consistent and controlled test conditions. The oxygen analyzers, sampling pump, NEA generator, and air compressor were started every morning and allowed to run for approximately 45 minutes to reach stable operating conditions. The system was then calibrated before testing began.

Before each test, the applicable flow rates were set by the flow meters and allowed to run for approximately 10 minutes to be certain that the NEA generator and the inerting manifold were stable and performing as desired. The NEA flow was then diverted from the tank during the tank-purging process to obtain ambient conditions in the tank. After all of the analyzers had stabilized and the tank was effectively purged, the data acquisition system and a stopwatch were started simultaneously. To establish a baseline, the system recorded the conditions inside the

tank for 60 seconds before the NEA inerting gas was diverted into the tank and the tank inerting process began. The data acquisition system continuously monitored the conditions inside the tank until the tank was inerted to the desired oxygen concentration, or for the desired duration, at which point data acquisition was stopped and flow rates for the next experiment could be set, and the tank was again purged. The target oxygen concentration for inerting the tank was 8-percent oxygen concentration by volume.

There were two basic categories of tests performed for the research project. The first were tests performed in the traditional cross-vented configuration of a CWT, indicative of Boeing aircraft manufactured in the Seattle area, and were focused on verifying the approach of equally distributing the inerting gas into each bay in a balanced manner to obtain an inert ullage. The second set of tests focused on minimizing the amount of NEA required to inert the tank by unevenly distributing the inerting gas to minimize the loss of NEA through the tank vents. These tests were performed with half the vent system blocked, which has been identified as important to maintaining a low predictable oxygen concentration in a CWT ullage [3].

2.2.1 Cross-Venting Configuration.

Tests were initially performed with the tank in the traditional cross-vented configuration. First, a test was performed by depositing the inerting gas in a volumetric distribution proportional to the volume of the bay in question. The total flow rate was developed by assuming a 20-minute inerting time and calculating using the estimated VTE of 1.6. The individual bay flow rates were calculated by multiplying the fraction of each bay volume by the total flow rate. The run was repeated several times slightly adjusting the bay flow rates until each bay reached 8-percent oxygen at approximately the same time (± 30 seconds). This was referred to as the balanced inerting run. This procedure was repeated twice with two different NEA percentage inerting gases (98% and 93%).

Next, tests were performed by unevenly distributing the inerting gas into the tank in an attempt to simplify the deposit manifold. The different bay concentrations were examined as well as the volumetric average oxygen concentration of the tank in an effort to determine the effectiveness of these methods.

A list of tests in the cross-venting configuration discussed in this report are given in table 2. This table gives a description of each test with NEA purity and bay flow rates as well as the time to inert used to calculate the flow rate.

TABLE 2. TABLE OF INERTING TESTS FOR THE CROSS-VENTED CONFIGURATION

Run No.	Description	NEA Purity	Time to Inert	Flow Rate	Bay Flow Rate					
					1	2	3	4	5	6
46	Manually Balanced, Cross Vented	95%	20	128	36	35	12	12	17	15
49	Uneven Distribution, Cross Vented, Efficient	95%	20	128	70	20	20	0	10	18
53	Uneven Distribution, Cross Vented, Efficient	95%	20	128	0	86	0	24	10	8
54	NEA Minimization, 8% Cal, NO X Vent	98%	20	128	34	35	13	13	16	17
55	NEA Minimization, 8% Cal, NO X Vent	93%	20	128	38	35	12	14	16	13

2.2.2 Blocked-Vent Configuration.

Tests were then performed with half the tank vent system blocked to simulate an aircraft modification that would only allow venting to one wing vent under normal operations. First, tests were conducted that allowed for the tank to be inerted in a balanced manner as discussed in the in the first paragraph in section 2.2.1. This was considered to have occurred when each bay reached 8 percent oxygen at approximately the same time (± 30 seconds). The total flow rate was again developed based on a 20-minute inerting time.

Next, tests were performed by unevenly distributing the inerting gas into the tank in a manner that would require the inerting gas to travel the farthest distance before venting to the tank exterior. Several different deposit schemes were attempted, and the relative bay oxygen concentrations were examined as well as the volumetric average oxygen concentration of the tank in an effort to determine the most effective method of depositing NEA.

Lastly, the optimal method was examined for applicability and sensitivity to critical parameters. The optimal method of depositing was repeated and the precise measured volume of gas required was deposited. Immediately, the sample system was shutoff (to not stimulate mixing) and the tank was allowed to sit for 30 minutes, turning the sample system on approximately every 10 minutes to monitor the diffusion of NEA throughout the tank. Also, the optimal deposit method was repeated with the same flow conditions established as a baseline (95% NEA, 20-minute inerting time) after tank modifications to gage the effect of these changes on the data. Several tests were then done with the optimal deposit method using different flow rates and NEA oxygen concentrations to determine the sensitivity of the NEA requirements for this method to changes in these parameters.

A list of tests in the blocked vent configuration, discussed in this report, are given in table 3. This table gives a description of each test with NEA purity and bay flow rates.

TABLE 3. TABLE OF INERTING TESTS FOR THE BLOCKED-VENT CONFIGURATION

Run No.	Description	NEA Purity	Time to Inert	Flow Rate	Bay Flow Rate					
					1	2	3	4	5	6
25	Balanced Deposit, No X Vent	95%	20	128	41	29	12	13	16	17
27	NEA Minimization, No X Vent	95%	20	128	0	77	41	0	10	0
30	NEA Minimization, No X Vent	95%	20	128	0	79	49	0	0	0
32	NEA Minimization, No X Vent	95%	20	128	0	0	128	0	0	0
33	Repeat 32, No X Vent, Monitor Diffusion	95%	20	128	0	0	128	0	0	0
92	Optimal Configuration, Baseline Repeat	95%	10	262	0	0	262	0	0	0
110	Optimal Configuration, Low Flow Rate	95%	40	70	0	0	70	0	0	0
111	Optimal Configuration, High Flow Rate	95%	20	128	0	0	128	0	0	0
112	Optimal Configuration, Low O ₂ Conc.	98%	20	85	0	0	85	0	0	0
113	Optimal Configuration, High O ₂ Conc.	93%	20	195	0	0	195	0	0	0

3. ANALYSIS.

Ullage washing can be described as an exchange of gases at different oxygen concentrations. The inerting gas is supplied to the fuel tank ullage space through a manifold, allowing for distribution of the NEA within in the fuel tank. The inerting gas displaces the existing ullage headspace gas, which consists of air (20.9% oxygen by volume) and fuel vapor. As NEA is supplied to the fuel tank, the oxygen concentration is reduced to a level that approaches, but theoretically never reaches, the oxygen concentration of the inerting gas (i.e., NEA 95% is 5% oxygen by volume).

3.1 DATA CALCULATIONS.

The following formulas were used to obtain and reduce the data. The primary calculations performed to determine testing parameters were the calculations of flow rate from the given inerting time of 20 minutes. Also, to obtain the balanced data, the volume flow for each bay was initially calculated based on the percentage of tank volume.

3.1.1 Calculations to Determine Testing Parameters.

To determine the flow rate needed to inert the tank in approximately 20 minutes, the total flow rate was calculated by multiplying the tank volume by an estimated VTE and then dividing by 20 minutes.

$$\text{Calculated Flow Rate} = \frac{\text{Tank Volume} * \text{Estimated VTE}}{20 \text{ Minutes}}$$

To determine the appropriate amount of NEA to deposit in each bay to ensure a balanced deposit of inerting gas, the volume flow rate for each bay was calculated based on the percentage of volume of the bay in question with respect to the entire tank volume.

$$\text{Bay Flow Rate} = \frac{\text{Bay Volume}}{\text{Tank Volume}} * \text{Calculated Flow Rate}$$

The bay volume to tank volume ratio can be obtained in table 1. This formula was used to initially calculate the flow rate for the bay in question, and the flow rate was slightly modified with repeated runs to obtain the desired consistency between the bays as discussed in section 2.2.2.1.

3.1.2 Calculations to Reduce Data.

It is advantageous to present the data in a manner which is easily applied to all fuel tanks and all NEA flow rates. It can be hypothesized that the volume of NEA deposited within the tank dictates how quickly or slowly a vented fuel tank becomes inert, given the assumption that the tank is homogenous and stores no gas (100% mixing, in flow = out flow). It also follows that this volume of gas, divided by the total volume of the tank would be constant, given a fixed oxygen concentration of gas deposited. To accomplish this, the time scale of the data was

nondimensionalized by applying the flow rate and fuel tank volume, which is defined as the volumetric tank exchange.

$$\text{Volumetric Tank Exchange} = \frac{\text{Time} * \text{Volume Flow Rate}}{\text{Fuel Tank Volume}} \quad (1)$$

When comparing different methodologies of inerting the tank, it is convenient to be able to express the oxygen concentration of the tank as a whole, even though the concentrations of the individual bays often vary. To achieve this, a weighted average by volume was calculated at each point in time. This average weighed the oxygen concentration of each bay with the volumetric percentage of each bay.

$$\text{Average } [O_2] = \frac{7.986[O_2 \text{ Bay 1}] + 5.823[O_2 \text{ Bay 2}] + 2.602[O_2 \text{ Bay 3}] + 2.602[O_2 \text{ Bay 4}] + 3.312[O_2 \text{ Bay 5}] + 3.312[O_2 \text{ Bay 6}]}{25.637} \quad (2)$$

3.2 INERTING SOLUTIONS.

3.2.1 Exact Solution.

An exact solution to fuel tank inerting was created by using a perfect mixing model to develop an equation in terms of the rate of change of ullage oxygen concentration with respect to time. This equation was solved and manipulated to allow for comparison of the exact solution to the nondimensional scheme developed in reference 2. The equation was determined to be the following:

$$\frac{O_{2 \text{ Amb}} - O_2(t)}{O_{2 \text{ Amb}} - O_{2 \text{ NEA}}} = 1 - e^{-Qt/V_{\text{Tank}}} \quad (3)$$

The left-hand term in the equation is referred to as the tank inerting ratio. This equation simply states that the tank inerting ratio is equal to 1 minus e to the negative volumetric tank exchange. This equation was solved for time-dependent oxygen concentration to give the following relationship.

$$O_2(t) = O_{2 \text{ Amb}} - [(O_{2 \text{ Amb}} - O_{2 \text{ NEA}})(1 - e^{-VTE})] \quad (4)$$

This equation allows for comparison of the data acquired with the exact solution calculated in reference 2. The complete solution is given in appendix A in that reference.

3.2.2 Empirical Solution.

Data acquired from previous FAA testing allowed for the creation of an empirical curve. An empirical relationship between volumetric tank exchange and inerting ratio was developed by compiling, averaging, and curve-fitting the data in reference 2. This empirical relationship

assumes a fourth-order polynomial curve fit which is given below. In this equation, x is the volumetric tank exchange [2].

$$\text{Tank Inerting Ratio} = -0.0145x^4 + 0.1345x^3 - 0.5275x^2 + 1.0873x - 0.0121 \quad (5)$$

Again, this equation was solved for time-dependent oxygen concentration to give the following relationship that allows for comparison with this acquired data.

$$O_2(t) = O_{2,Amb} - [(O_{2,Amb} - O_{2,NEA}) * (-0.0145VTE^4 + 0.1345VTE^3 - 0.5275VTE^2 + 1.0873VTE - 0.0121)] \quad (6)$$

4. DISCUSSION OF RESULTS.

To test as many inerting concepts as possible and to extend the application of the knowledge gained from these experiments, tests were performed with both the standard cross-venting configuration as well as with half the vent system blocked. Although the standard venting configuration would be the easiest and most cost-effective to adopt from an installation standpoint, previous ground and flight testing (see section 1.1.2) indicated that it may be beneficial to completely or partially block venting flow through one side of the vent system. As previously stated, cross venting of vented fuel tanks can have a negative effect on the ability of the tank to remain inert during some ground and flight operations.

4.1 CROSS-VENTING CONFIGURATION.

The cross-venting configuration allowed the tank to vent in a manner consistent with the current vent system in a Boeing 747SP CWT. Virtually all Boeing aircraft manufactured in the Seattle area have center wing tanks that vent in a similar manner. The focus of this portion of the testing was to validate the existing data obtained in simple rectangular tanks and to examine ways to simplify NEA distribution to inert a vented fuel tank.

4.1.1 Balanced Data.

The tank was inerted several times with NEA 95% with the goal of balancing the flow into each bay so that each individual bay reaches 8-percent oxygen concentration at the same time. This “balanced run” was used to establish a baseline for the standard venting configuration. Figure 8 gives the oxygen concentration measured in each bay and the vent channel for the test that established the baseline data with 95% NEA. This graph illustrates that the flow into each bay was balanced in such a manner that each bay reached the target oxygen concentration at virtually the same time.

This process was repeated using both 98% and 93% NEA. The volumetric average oxygen concentration of the tank was calculated using the formula discussed in section 3.3, and the data was nondimensionalized and presented in terms of VTE for the three different NEA values. This data can be seen in figure 9. The results came out as expected and were consistent with previous testing, with these numbers indicating an approximate VTE of 1.6 for inerting a fuel tank to 8-percent oxygen concentration with 95% NEA.

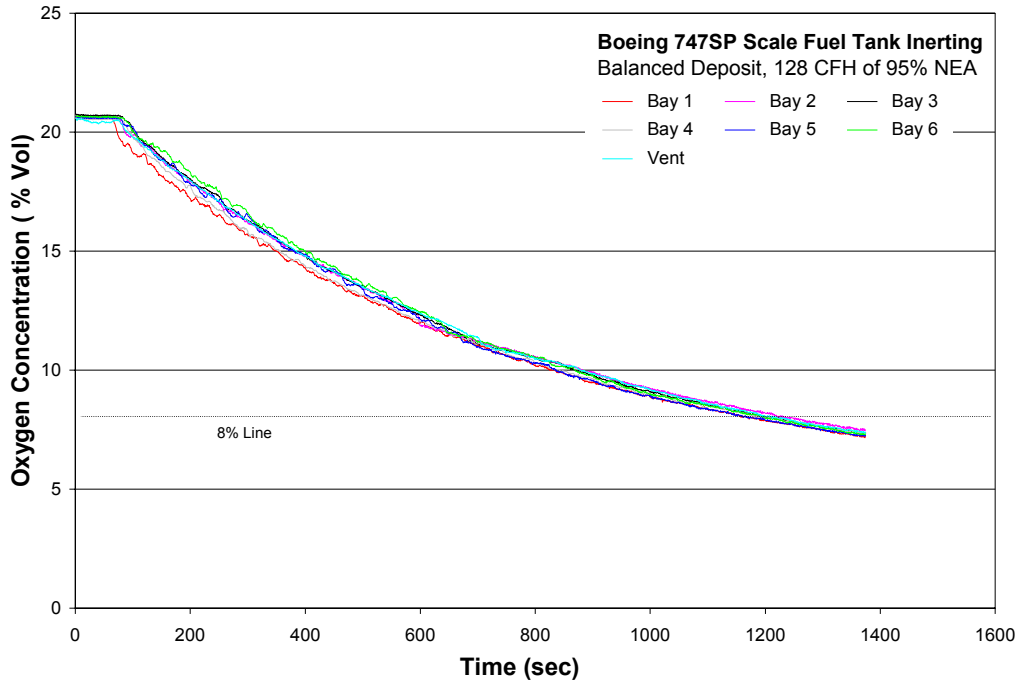

FIGURE 8. BAY OXYGEN CONCENTRATION DATA FOR THE BALANCED INERTING TEST IN THE CROSS-VENTED CONFIGURATION

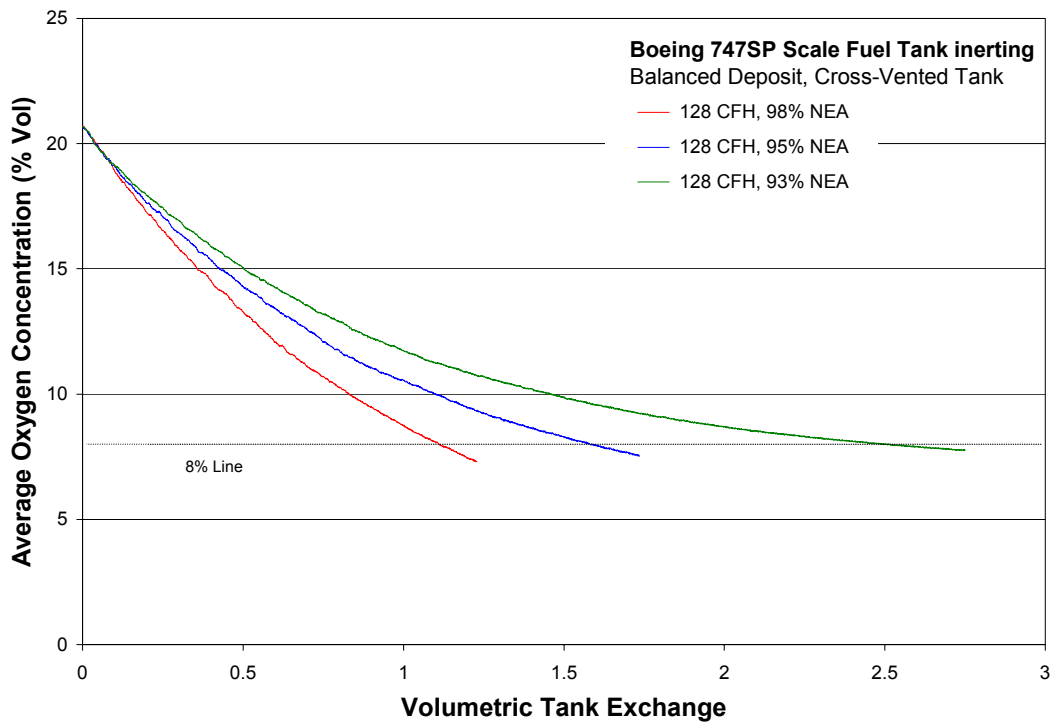

FIGURE 9. WEIGHTED AVERAGE TANK OXYGEN CONCENTRATION DATA FOR THE BALANCED DEPOSIT METHOD FOR 93%, 95%, AND 98% NEA

Figure 10 gives this inerting data compared with the empirical curve developed from the data acquired in reference 2 and the test data acquired from the Boeing 737-700 in reference 3 as well as the exact solution described in section 3.2.1. The data is very consistent from test to test. The large deviation and different shape of the 737 data is most likely due to the large amount of lag in the data due to the nature of the voluminous sample system for the testing. Also, the process requires a VTE slightly greater than the theoretical value (exact solution). This discrepancy from the lab research is probably caused by a deficiency in the design that tended to deposit slightly more NEA in the vicinity of the tank vent. The shape of the inerting curve also shows that the VTE is somewhat sensitive to the oxygen concentration value at 8-percent for 95% NEA and very sensitive for the 93% NEA. For inerting with 95% NEA, a difference of 0.3% oxygen (outside the accuracy of most analyzers) can change the VTE required 0.1 (6% error given a VTE of 1.7). This illustrates the difficulty in assuring an accurately predicted VTE, given the difference in answers illustrated in figure 10.

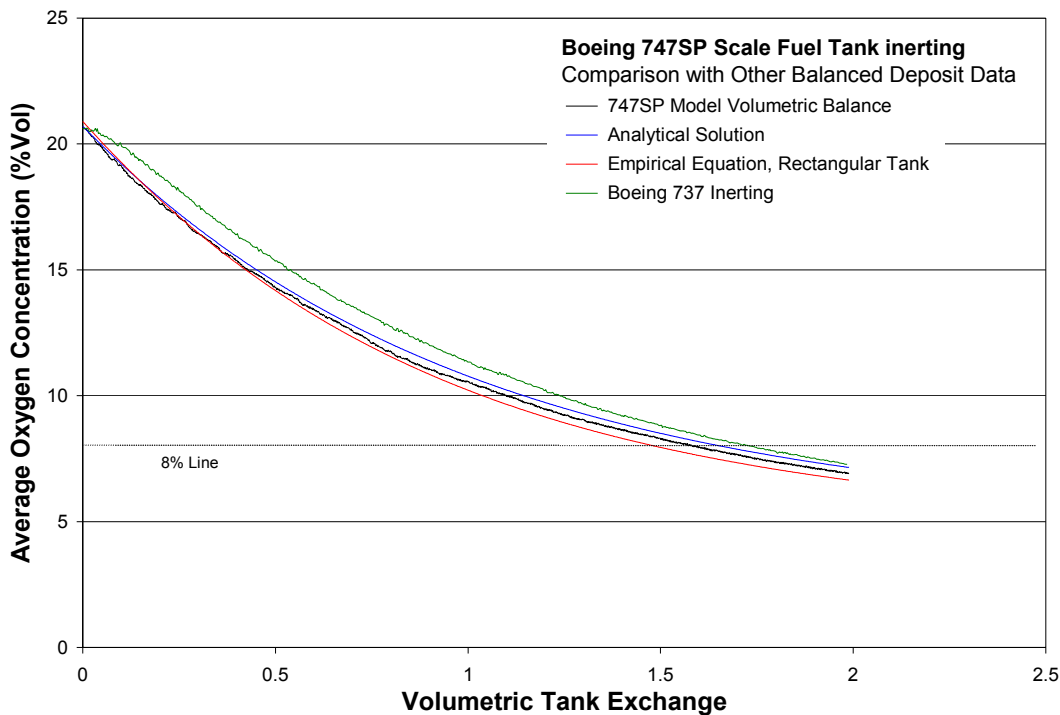

FIGURE 10. COMPARISON OF PREVIOUS DATA WITH WEIGHTED AVERAGE TANK OXYGEN CONCENTRATION FOR THE BALANCED DEPOSIT METHOD

4.1.2 Uneven Distribution Testing.

The tank was inerted several times with 95% NEA with the goal of minimizing the amount of NEA required to inert the tank and/or simplify the manifold design. Figure 11 gives the measured bay oxygen concentration data with respect to time for a typical uneven distribution test. The wide spread of measured oxygen concentrations from bay to bay illustrates a disadvantage of this deposit method. However, at the approximate time the volumetric average reaches 8-percent oxygen, all bays have an oxygen concentration of less than 10 percent.

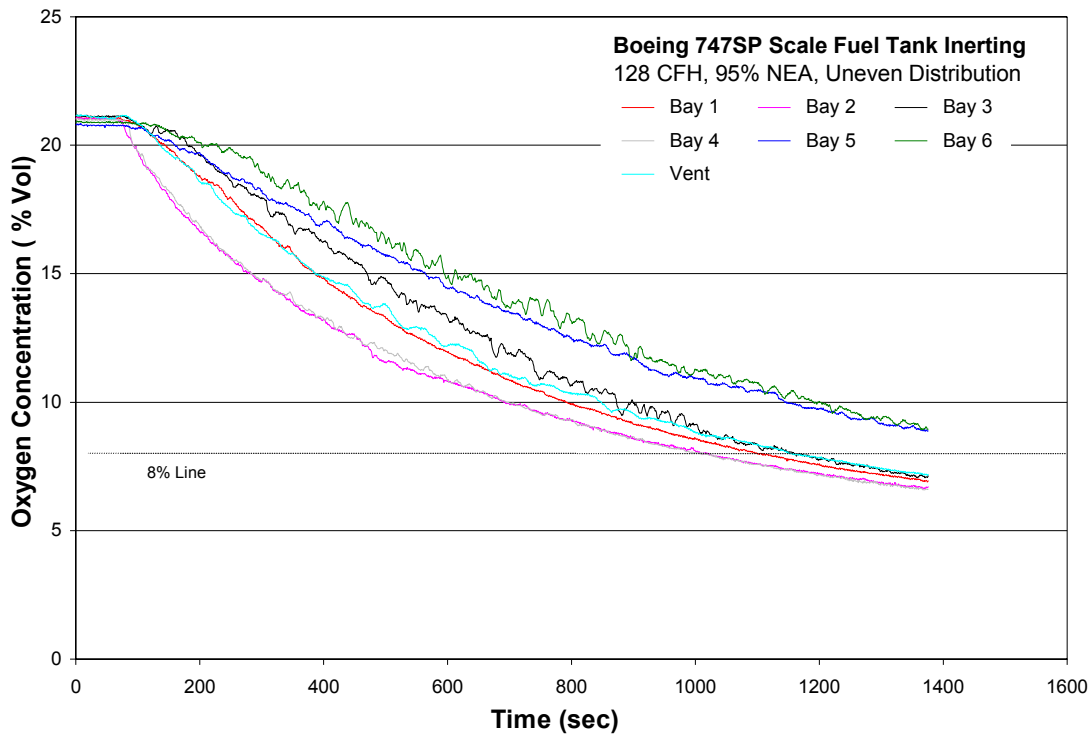

FIGURE 11. BAY OXYGEN CONCENTRATION DATA FOR A TYPICAL UNEVEN DISTRIBUTION INERTING TEST

In order to make fair comparisons with the previous balanced inerting results, the volumetric weighted average results were compared for several uneven distribution tests with the balanced inerting results. Figure 12 illustrates that, although the efficiency of the inerting process exhibited little change from test to test, significant simplification of the deposit manifold could be made with very little effect in the amount of NEA required to inert the tank.

4.2 BLOCKED-VENT CONFIGURATION.

To test a scenario that would eliminate cross venting and significantly reduce wind effects, as shown in previous ground and flight tests performed on a 737, the left vents (venting out of the right wing) were blocked. Since this modification also eliminated the opportunity for the gas to exit the tank on the left side, elbows were installed to direct the NEA stream away from the open right vents.

4.2.1 Uneven Distribution.

To minimize the amount of NEA required to inert the tank with half the vent system blocked, first the theoretical, balanced flow rates were manually adjusted to allow for each bay to reach the target oxygen concentration of 8 percent. A balanced run was achieved (figure 13), and again, the results pointed to a VTE of 1.6 for balanced inerting in a blocked vent scenario.

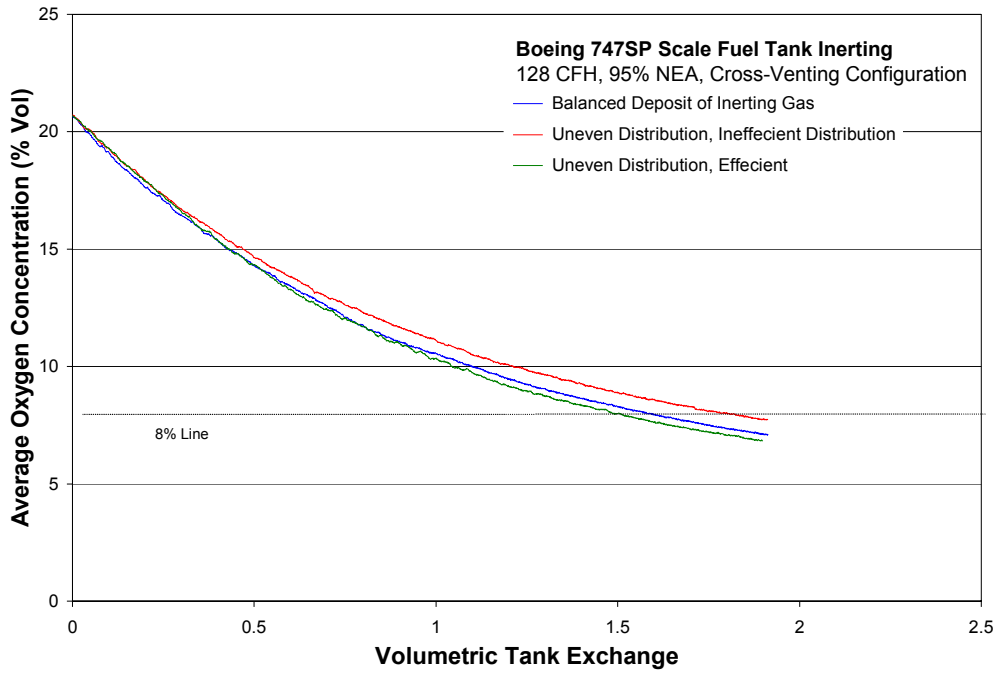

FIGURE 12. WEIGHTED AVERAGE TANK OXYGEN CONCENTRATION FOR SEVERAL UNEVEN DISTRIBUTION TESTS WITH BALANCED DEPOSIT DATA

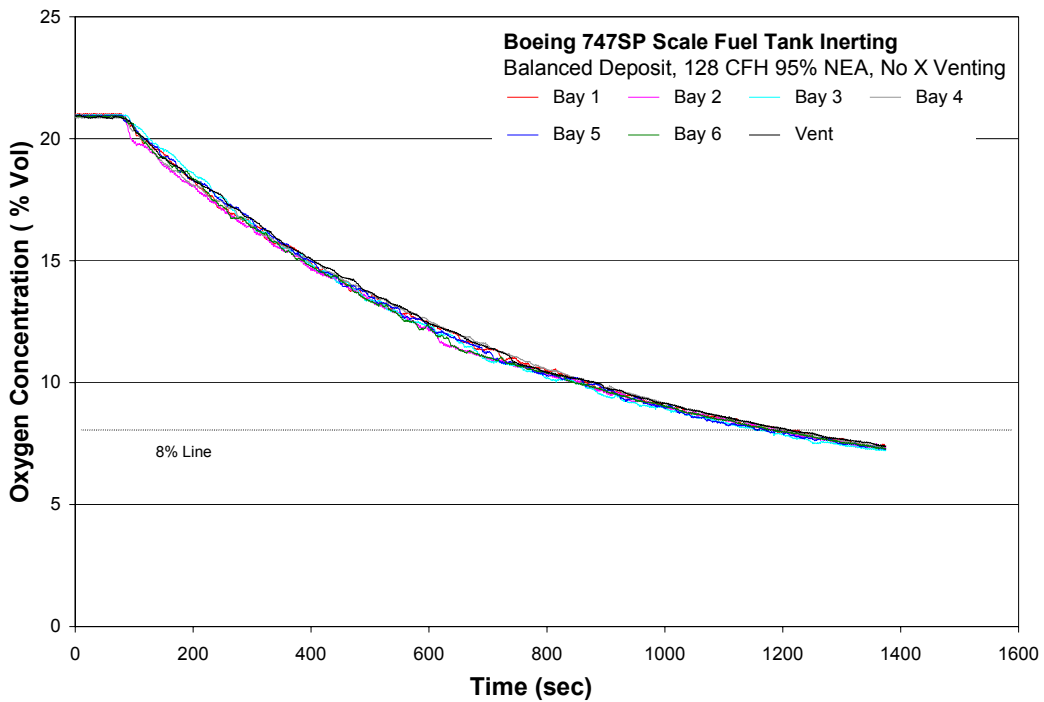

FIGURE 13. BAY OXYGEN CONCENTRATION DATA FOR THE BALANCED INERTING TEST WITH ONE VENT BLOCKED

Next, NEA was deposited in the tank in such a manner as to increase the amount of ullage that must be displaced by the inerting gas flow before inerting gas begins to flow from the open vent. Figure 14 shows an uneven distribution test, designed to simplify the complexity of the inerting gas deposit manifold and decrease the quantity of NEA required to inert the tank. This method was the optimal method developed during the testing described. In the blocked flow configuration previously described, a single deposit into bay 3 (100% flow) achieved a VTE of 1.4, a 12% reduction in inerting gas required. These test results give the optimal method for installing 95% NEA into the 747SP CWT at a flow rate to support a 20-minute inerting time.

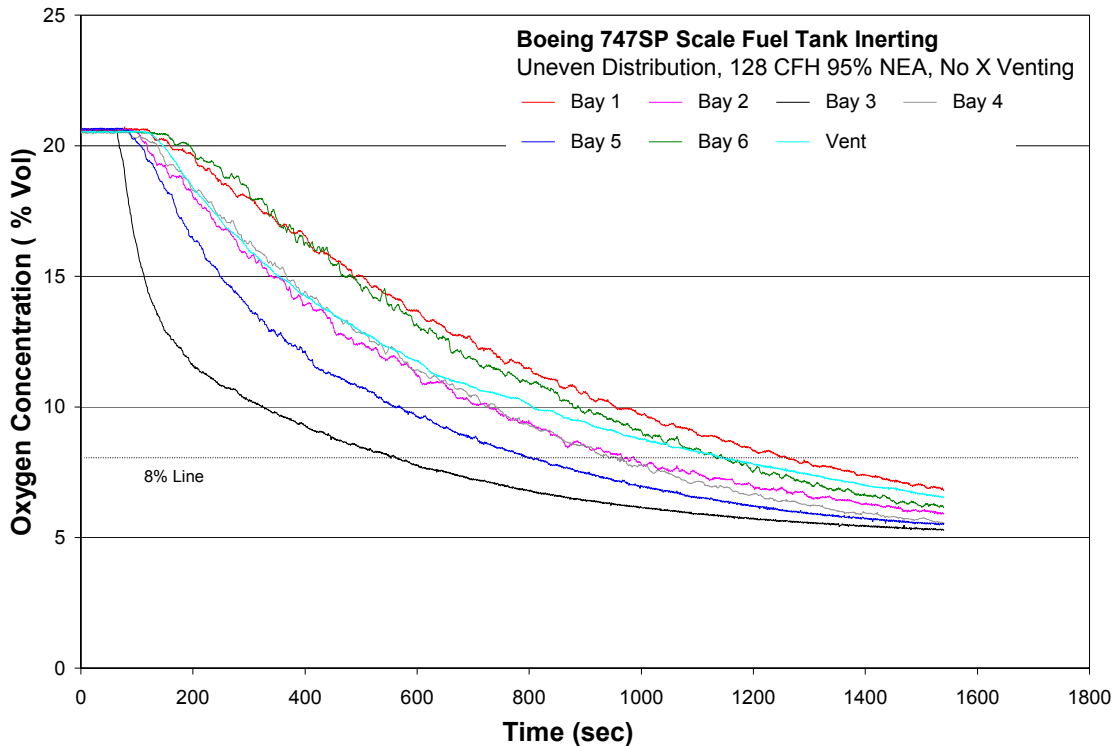

FIGURE 14. BAY OXYGEN CONCENTRATION DATA FOR A TYPICAL UNEVEN DISTRIBUTION TEST WITH ONE VENT BLOCKED

Figure 15 gives the weighted volumetric average oxygen concentration of these results and several uneven distribution tests compared with the balanced flow test. The results illustrated that significantly simplifying the inerting gas deposit method could show a modest improvement in inerting efficiency.

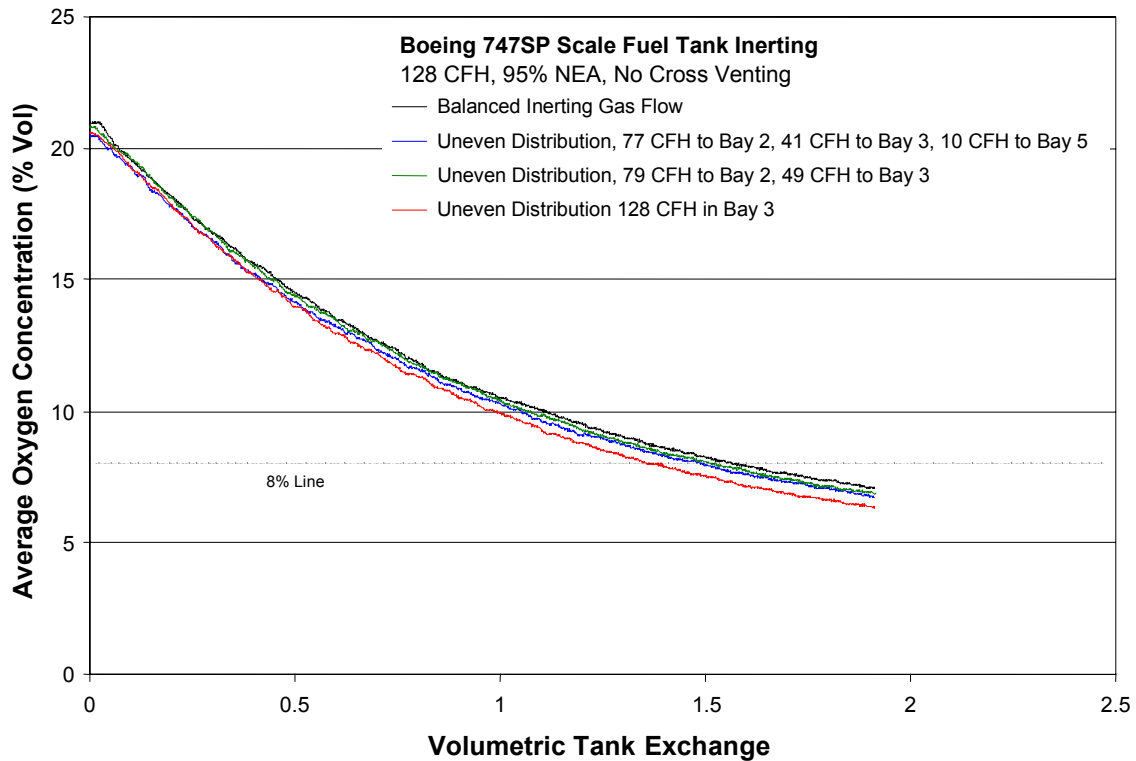

FIGURE 15. WEIGHTED AVERAGE TANK OXYGEN CONCENTRATION FOR UNEVEN DISTRIBUTION METHODS WITH BALANCED DEPOSIT METHOD DATA

4.2.2 Equalization of Bay Oxygen Concentration.

To show that all of the bays eventually approach the same oxygen concentration, the optimal deposit method test was repeated, but the NEA was shutoff when the necessary VTE, established in the above run, was deposited in the tank. The oxygen sampling system was shutoff for three 10-minute intervals and turned on for 20 seconds to obtain data approximately every 10 minutes while the ullage gas diffused within the tank. Figure 16 gives the results of this test, which illustrates that, although the initial oxygen concentration in each bay after inerting was within a band of 3-percent oxygen (6.5 to 9.5), in less than 20 minutes the band was less than 1-percent oxygen.

4.2.3 Sensitivity of Optimal Case.

Although the optimal case did offer a more efficient inerting process and significantly decreased manifold weight and complexity, this was only validated at one flow rate and NEA oxygen concentration (95% NEA at 128 CFH). It was essential to ensure that this optimal deposit case was not sensitive to flow rate and NEA percent selected for inerting the tank.

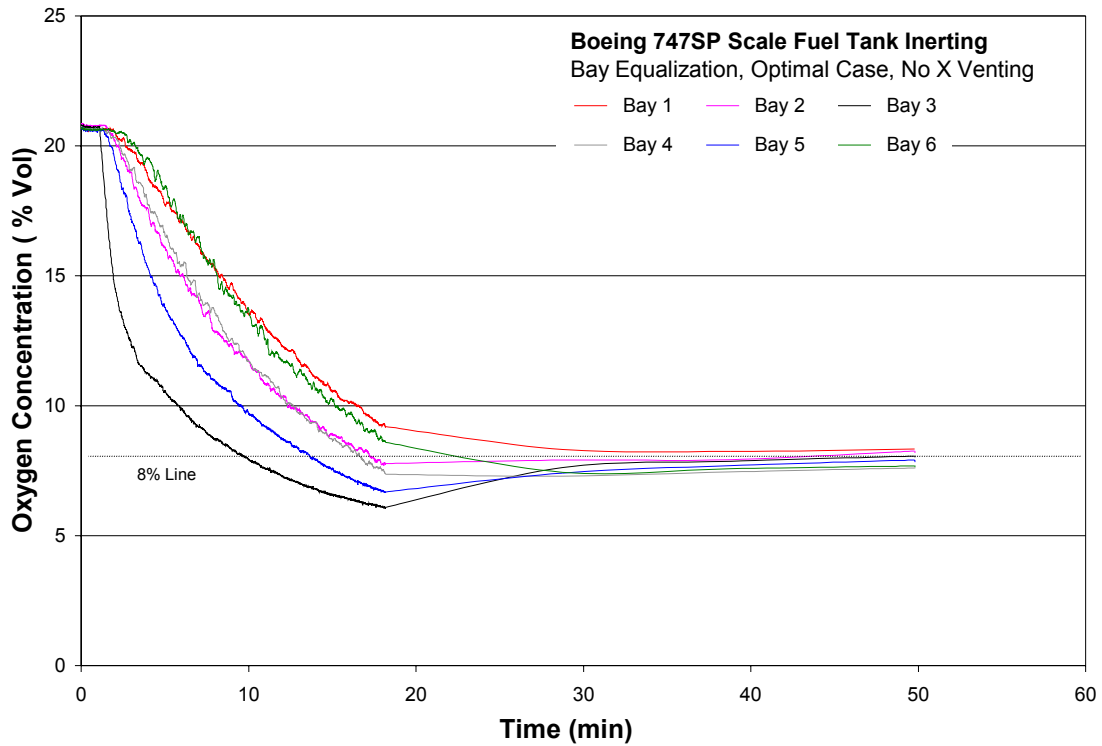

FIGURE 16. BAY OXYGEN CONCENTRATION ILLUSTRATING DIFFUSION AFTER TYPICAL UNEVEN DISTRIBUTION TEST

After the previously discussed experiments were completed, the tank was opened for maintenance, and small modifications to the tank were made to allow the tank to better resemble the observed full-scale test article. The optimal case was then repeated to ensure that the modifications did not cause an adverse effect on the optimal case determined (figure 17). Significant differences can be observed in the individual bay inerting data, while the weighted average data and resulting VTE to inert to 8% was very similar. This would imply that the tank optimal deposit method was still valid after the tank modifications, but additional research is required to validate the most efficient method of NEA deposit.

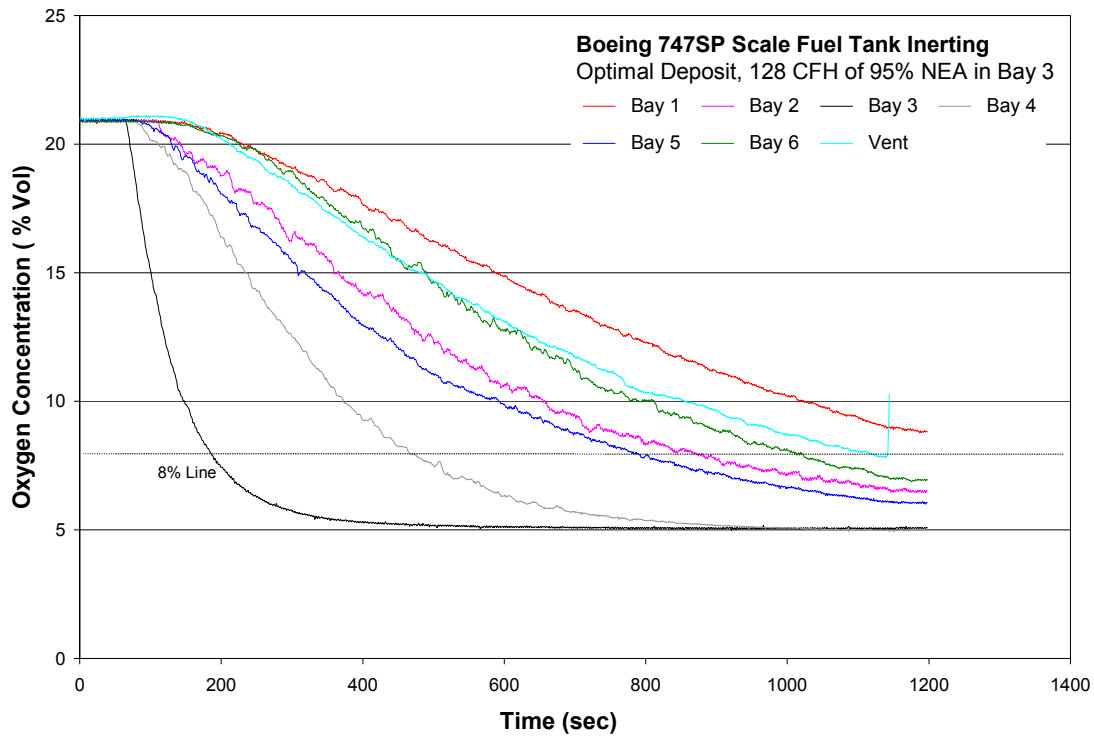

FIGURE 17. REPEAT OF OPTIMAL DEPOSIT CASE AFTER TANK MAINTENANCE AND MODIFICATION

4.2.3.1 Sensitivity to Flow Rate.

To determine the sensitivity of the optimal deposit method to the flow rate, successive tests were performed with the primary test flow rate of 128 CFH (approximately 20-minute inerting time), as well as with 70 CFH and 245 CFH using 95% NEA. The two latter flow rates represent approximately half and double the primary flow rate studied. These flow rates have a direct effect on inerting time (approximately 40- and 10-minute inerting time). Figure 18 gives this weighted average oxygen concentration versus VTE for three different flow rates for the optimal deposit method. Very small differences in the data were observed due to the change in deposit flow implying that the inerting efficiency of a deposit method is not dependent upon flow rate.

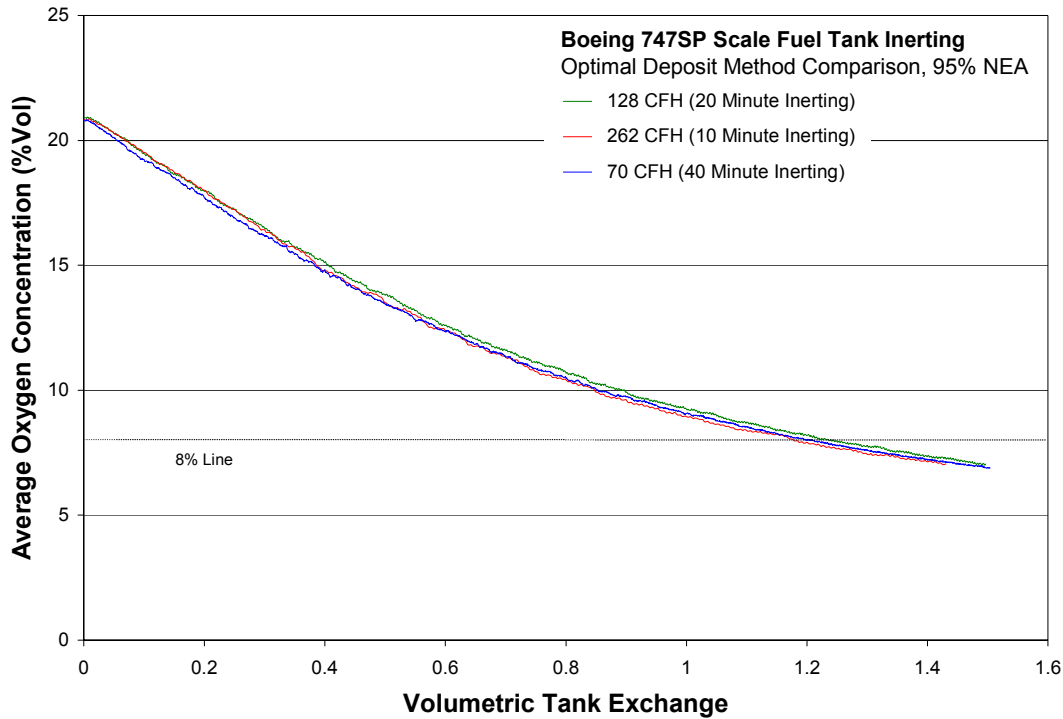

FIGURE 18. COMPARISON OF AVERAGE TANK OXYGEN CONCENTRATION FOR THE OPTIMAL DISTRIBUTION METHODS FOR DIFFERENT FLOW RATES

4.2.3.2 Sensitivity to NEA Percentage.

To determine the sensitivity of the optimal deposit method to the NEA oxygen concentration, successive tests were performed with the primary test NEA percentage of 95 (5 percent oxygen), as well as with NEA of 98% and 93%. The two latter oxygen concentrations are more and less pure and represent the range of practical oxygen concentrations used to inert a tank to 8% with using an air separation process such as hollow-fiber membrane technology. Figure 19 gives this data compared with the balanced deposit data in figure 9. This illustrates that the optimal deposit data was consistently better than the balanced deposit data allowing for the optimal deposit method to be predictable in terms of resulting oxygen concentration after a given VTE deposited regardless of the NEA percentage used.

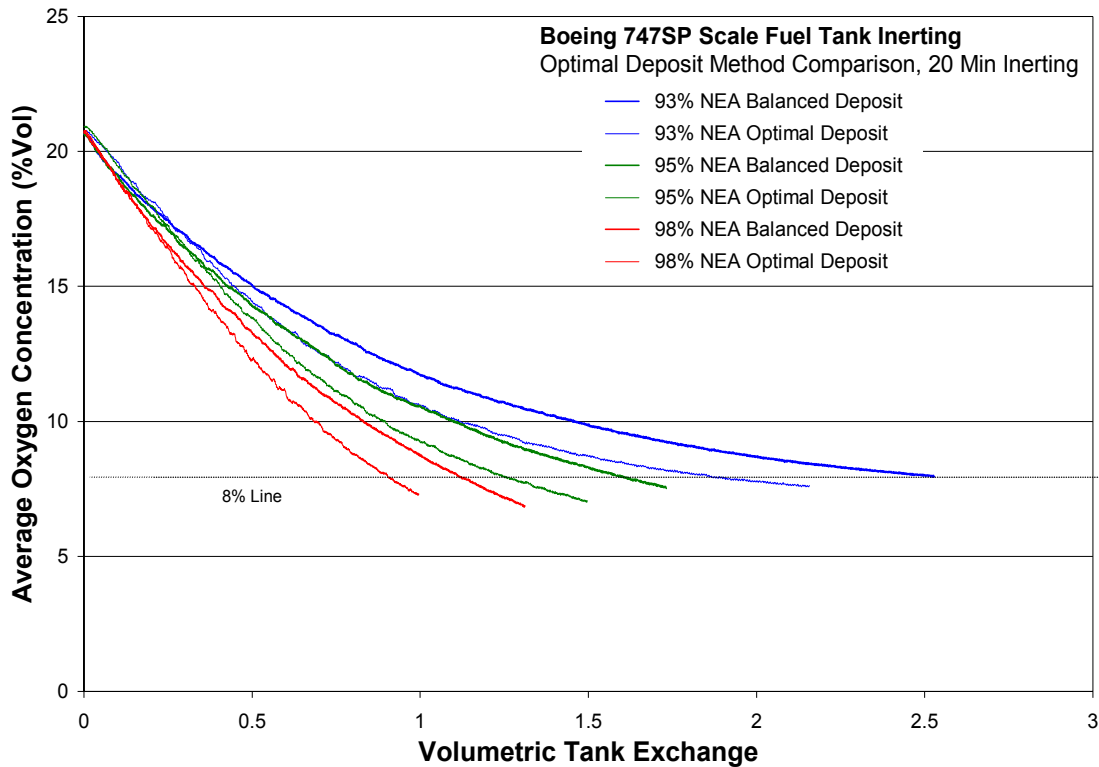

FIGURE 19. COMPARISON OF AVERAGE TANK OXYGEN CONCENTRATION FOR THE OPTIMAL DISTRIBUTION METHODS FOR DIFFERENT NEA PERCENTAGES

4.2.4 Comparison With Full-Scale Test Article.

To validate the ability to use scale modeling to develop an NEA distribution system, the results of the optimal case developed with the scale model testing were compared with data acquired from the 747SP ground-based inerting full-scale test article. Figure 20 gives the data presented in figure 17 for the optimal deposit method and was compared with the same deposit scenario on the full-scale test article. Due to the scale difference, the data was presented in terms of the overall VTE or volumetric tank exchange of the total deposit volume. The data illustrated good agreement in bay-to-bay oxygen concentration evolution during the inerting process. All bays still reached the target oxygen concentration of 10-percent oxygen by volume. The primary discrepancy with the scale model data is with the agreement of bay 4. Bay 4 in the full-scale test article appears to “compete” for in-flow from several bays, causing the oxygen concentration to oscillate as it reduces.

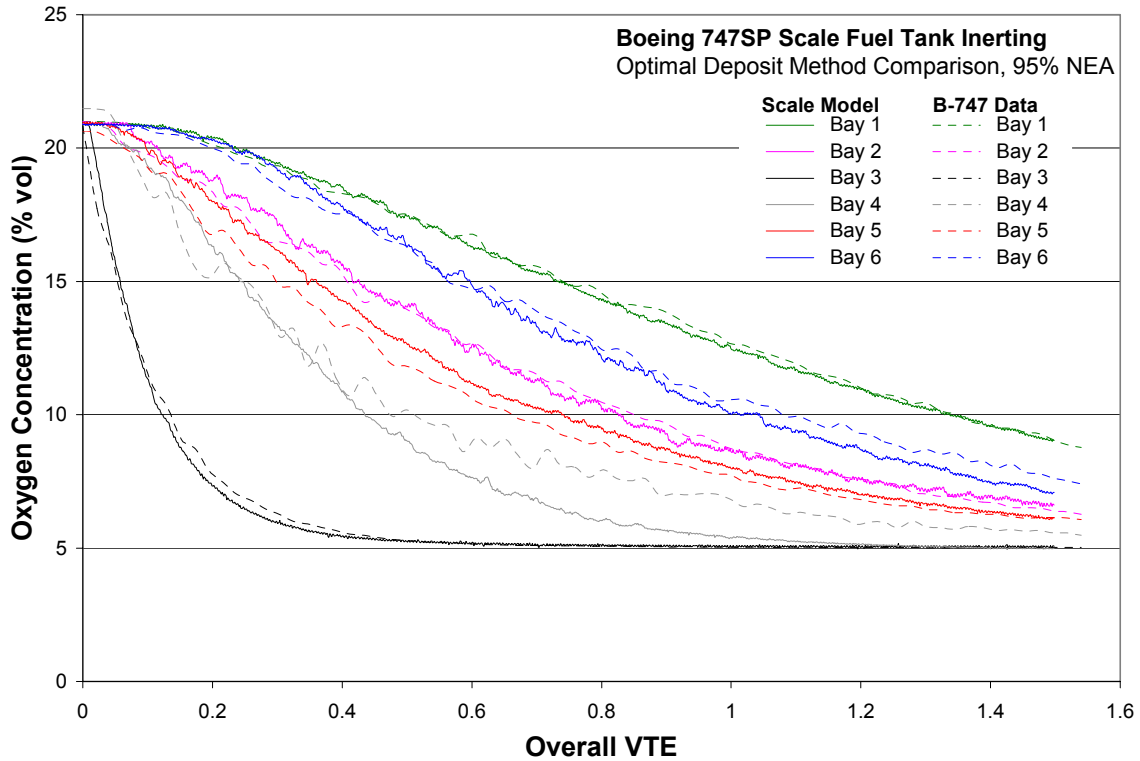

FIGURE 20. COMPARISON OF BAY INERTING DATA FOR BOTH THE SCALE MODEL AND THE FULL-SCALE TEST ARTICLE

Figure 21 illustrates that the observed small discrepancies in the individual bay oxygen concentrations between the scale model and the full-scale aircraft have little, if any, effect on the average oxygen concentration data when compared. The average ullage oxygen concentration data for both the scale tank and the full-scale test article are virtually identical and predict a VTE of 1.24 and 1.28 respectively.

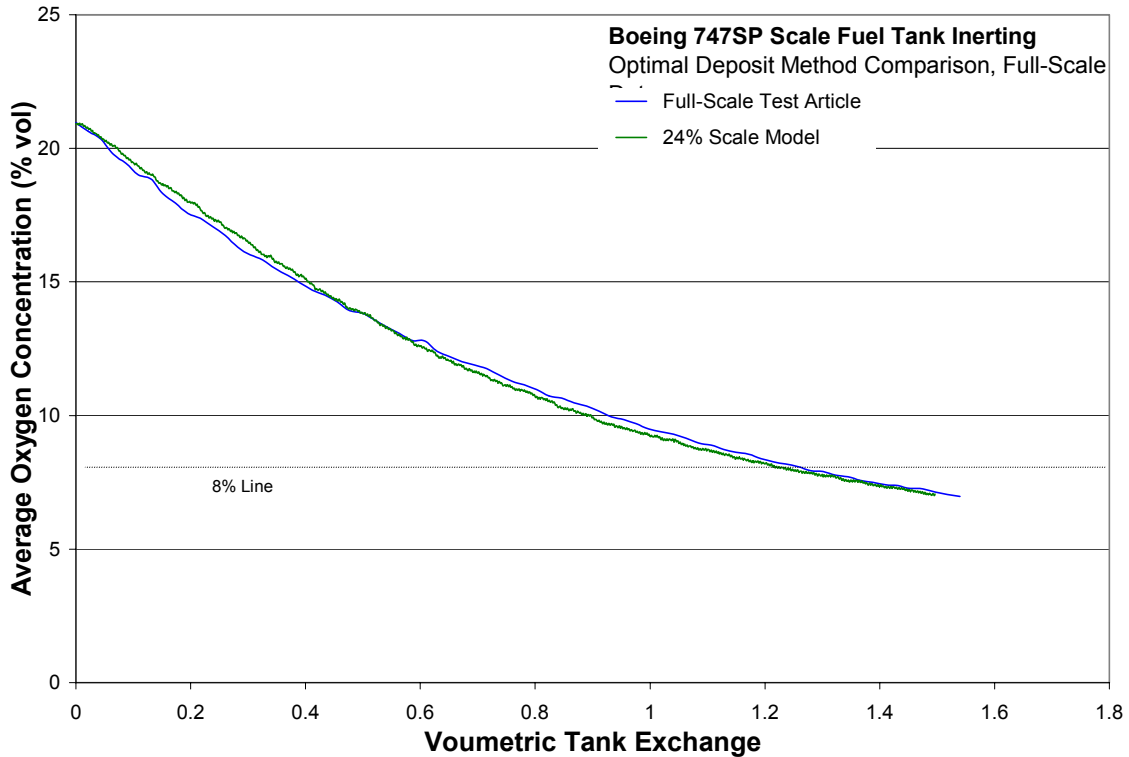

FIGURE 21. COMPARISON OF TANK AVERAGE OXYGEN CONCENTRATION FOR BOTH THE SCALE MODEL AND THE FULL-SCALE TEST ARTICLE

5. SUMMARY OF FINDINGS.

Experiments in the scale Boeing 747SP center wing tank verified that the VTE established from research with a simple box-style tank can be achieved in a more complex structure. It also indicated that modification of the venting configuration would positively impact the inerting process. Experimentation with different distributions into the tank bays showed that a volumetrically balanced inerting of all the bays, requiring a rather complex manifold, would allow for a VTE of 1.6 to inert the tank to an average oxygen concentration of 8 percent by volume. This is consistent with previous experiments in simple rectangular tanks. However, a focused flow of NEA into one bay, furthest away from the vent exits, will cause the least amount of mixing from bay to bay and allow more air to vent from the tank through the vent bays before inert gas begins to mix in. This has the effect of improving the efficiency of the inerting process and allows for the tank to reach the target oxygen concentration of 8-percent oxygen with a VTE of 1.3.

This configuration was not sensitive to flow rate as it allowed for a similar VTE to reach 8-percent oxygen for the cases of both double and half the flow rate (and inerting time) of the baseline case. When inerting gases of other NEA oxygen concentrations were used (NEA 98% and 93%), a comparable increase in inerting efficiency was observed, when compared with balanced inerting gas deposits, illustrating that the optimal deposit case was not sensitive to the oxygen concentration of the inerting gas. The optimal deposit case results obtained from the

scale tank testing compared well with data acquired on the full-scale aircraft. Some small differences in bay-to-bay oxygen concentrations were observed, but the same VTE was required to inert the ullage to 8-percent oxygen concentration in both the scale model and the full-scale test article.

6. REFERENCES.

1. “Fuel Tank Harmonization Working Group Final Report,” Aviation Rulemaking Advisory Committee, July 1998.
2. Burns, Michael and Cavage, William M., “Inerting of a Vented Aircraft Fuel Tank Test Article With Nitrogen-Enriched Air,” DOT/FAA/AR-01/6, April 2001.
3. Burns, Michael and Cavage, William M., “Ground and Flight Testing of a Boeing 737 Center Wing Fuel Tank Inerted With Nitrogen-Enriched Air,” DOT/FAA/AR-01/63, August 2001.
4. “A Review of the Flammability Hazard of Jet A Fuel Vapor in Civil Transport Aircraft Fuel Tanks,” Fuel Flammability Task Group, DOT/FAA/AR-98/26, June 1998.
5. Shepherd, J., E., et. al., “Jet A Explosions – Field Test Plan 1/4-Scale Experiments TWA 800 Simulation Flight,” TWA Flight 800 Docket Materials DCA-96-MA070, Docket No. SA-516, Exhibit No. 20E, August 2000.

APPENDIX A—FIGURES AND TABLES USED TO CONSTRUCT MODEL OF
BOEING 747SP CENTER WING TANK

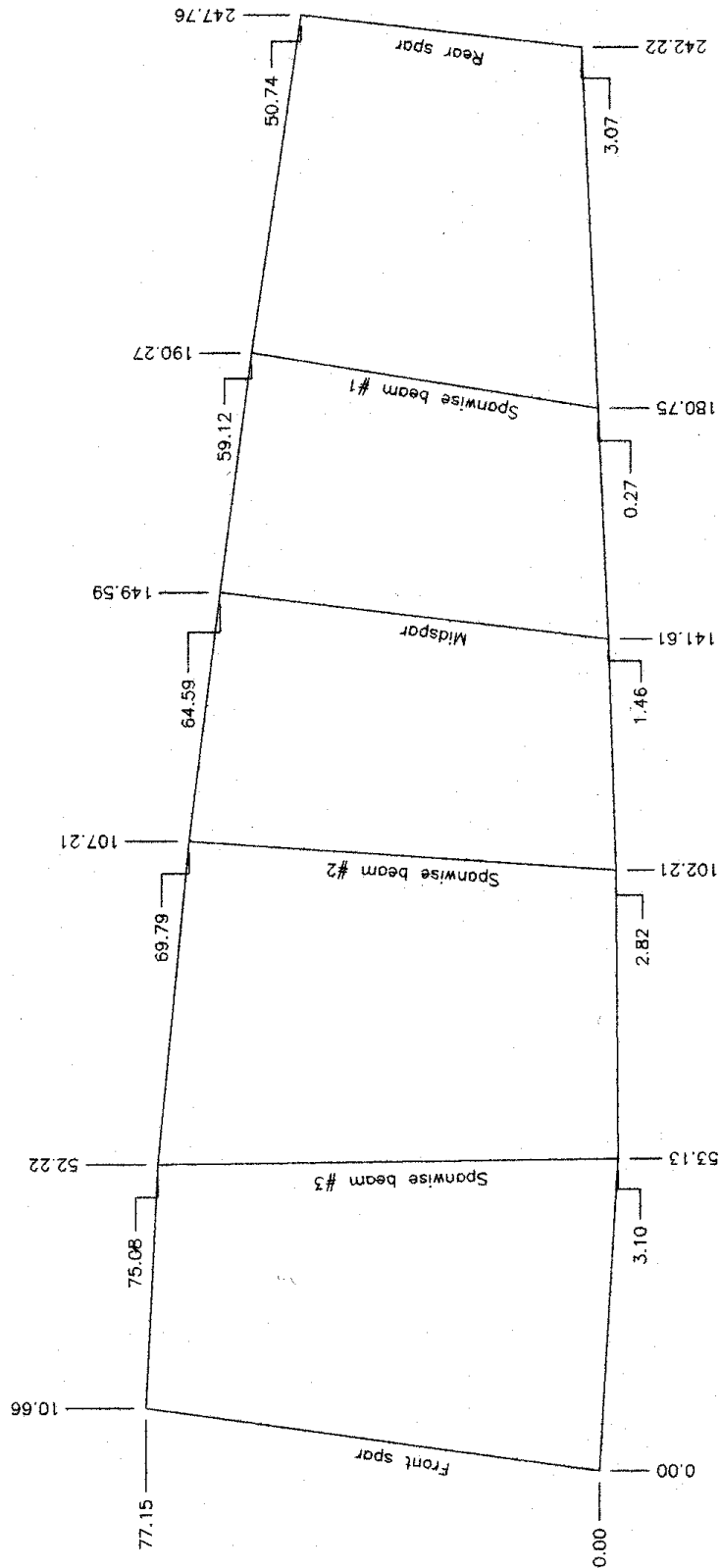

FIGURE A-1. SIDE VIEW OF A 747-100/SP CENTER WING TANK ILLUSTRATING
SPANWISE BEAMS AND SPARS

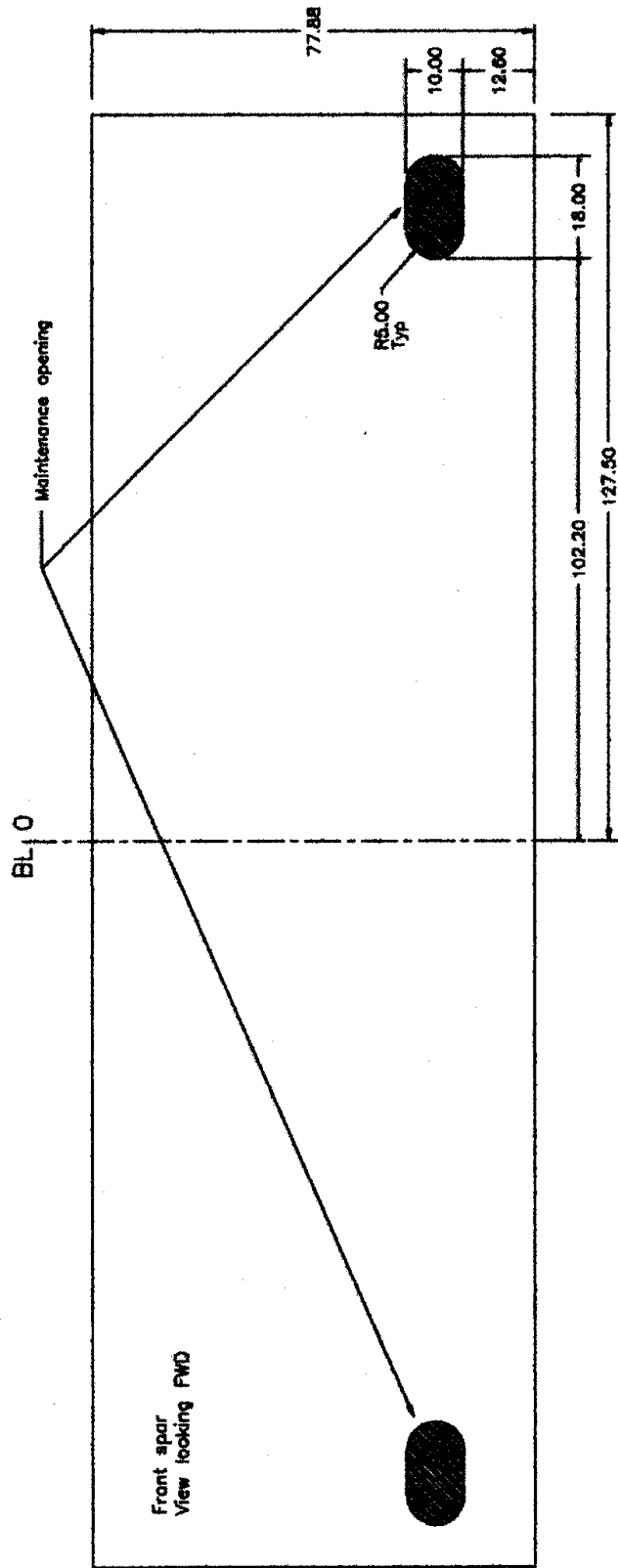

FIGURE A-2. FRONT VIEW OF FRONT SPAR OF 747-100/SP CENTER WING TANK ILLUSTRATING SPANWISE BEAMS AND SPARS

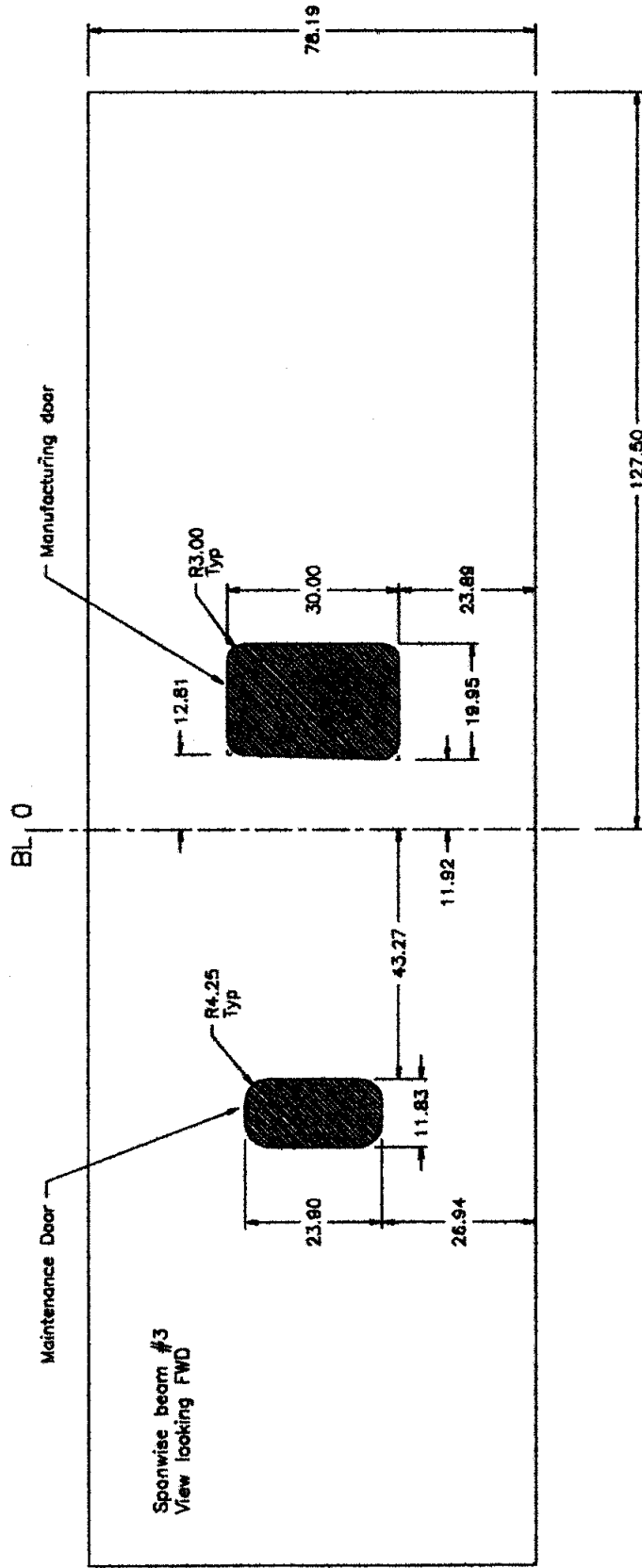

FIGURE A-3. FRONT VIEW OF SPANWISE BEAM 3 OF 747-100/SP CENTER WING TANK ILLUSTRATING SPANWISE BEAMS AND SPARS

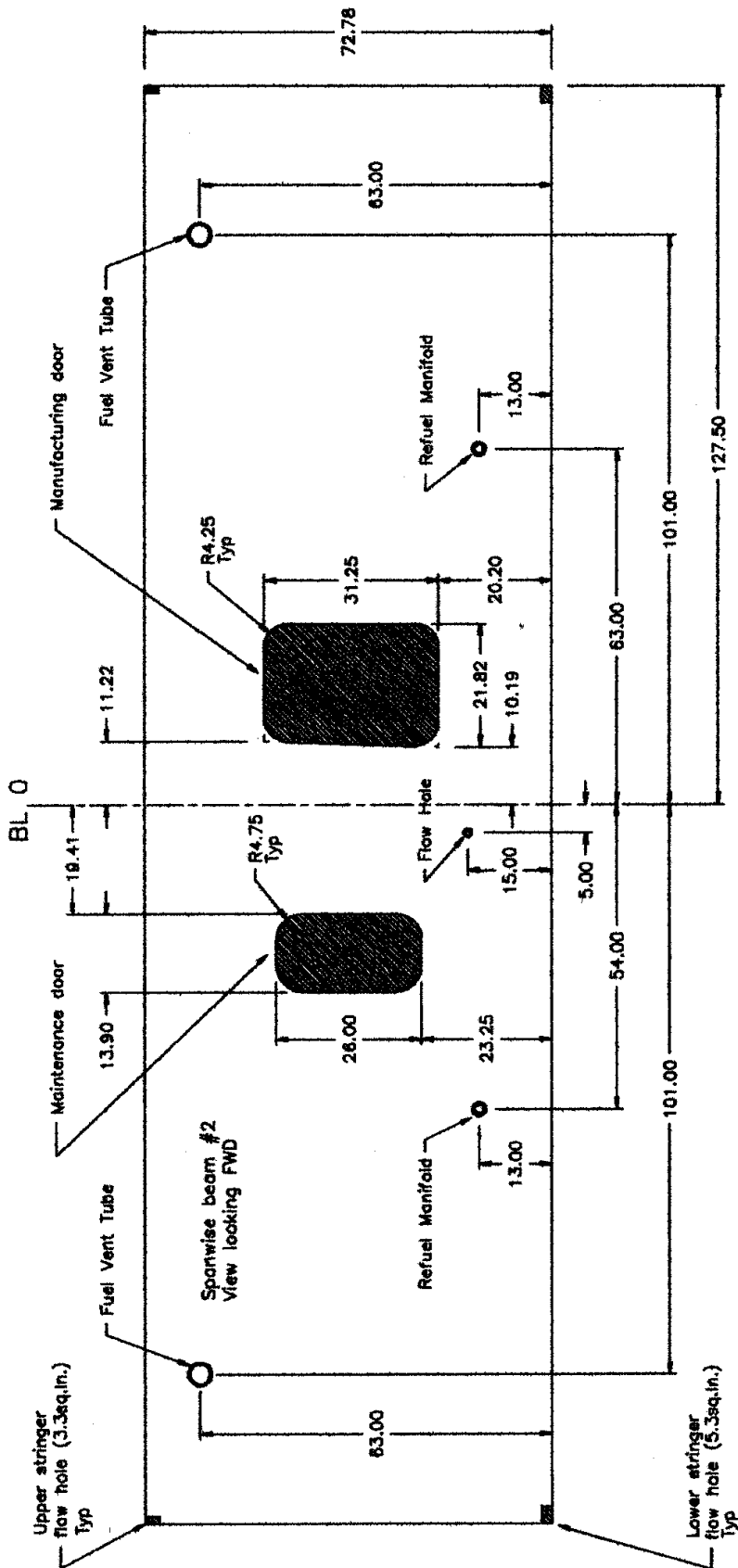

FIGURE A-4. FRONT VIEW OF SPANWISE BEAM 2 OF A 747-100/SP CENTER WING TANK ILLUSTRATING SPANWISE BEAMS AND SPARS

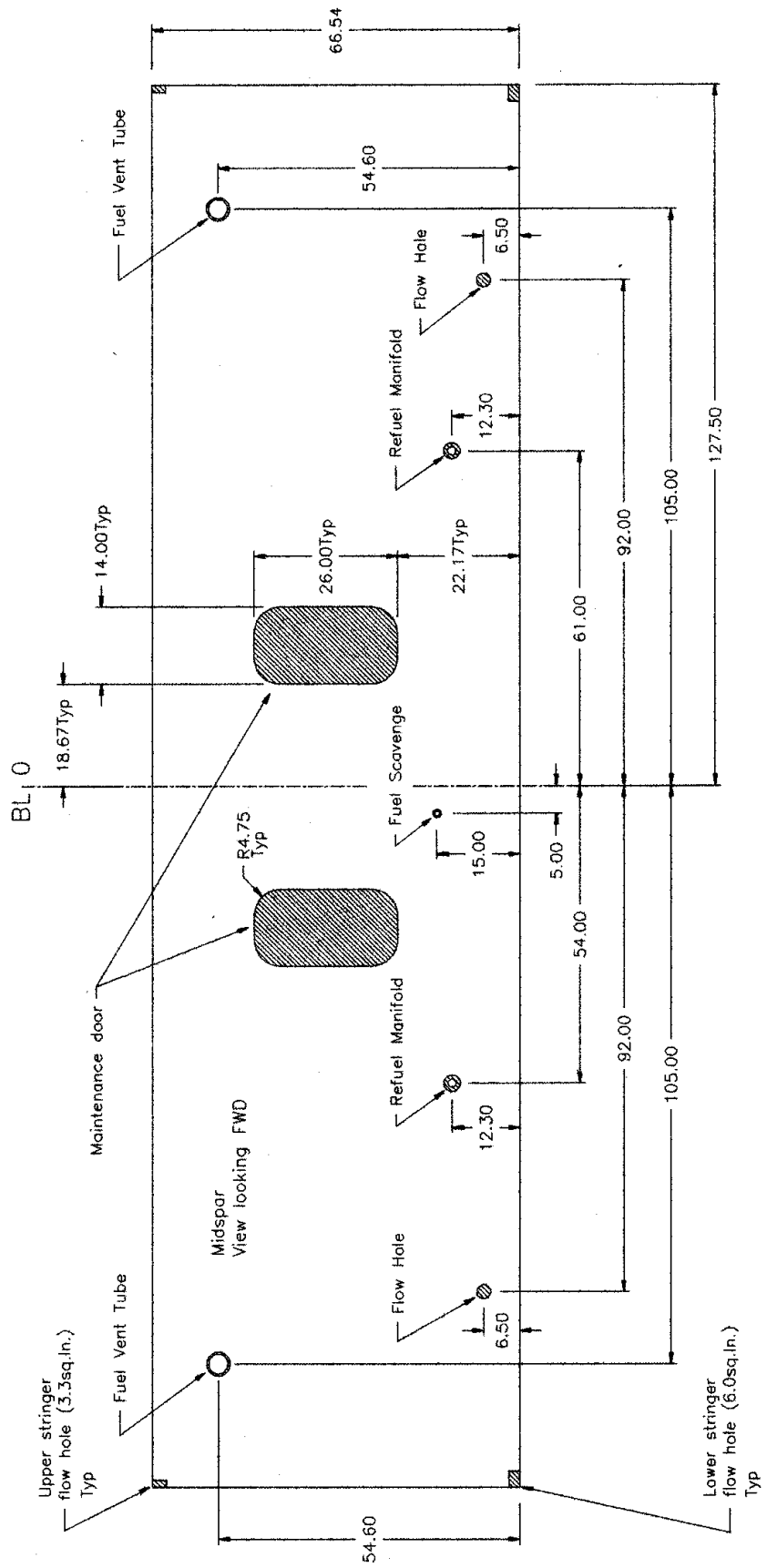

FIGURE A-5. FRONT VIEW OF MIDSPAR OF A 747-100/SP CENTER WING TANK ILLUSTRATING SPANWISE BEAMS AND SPARS

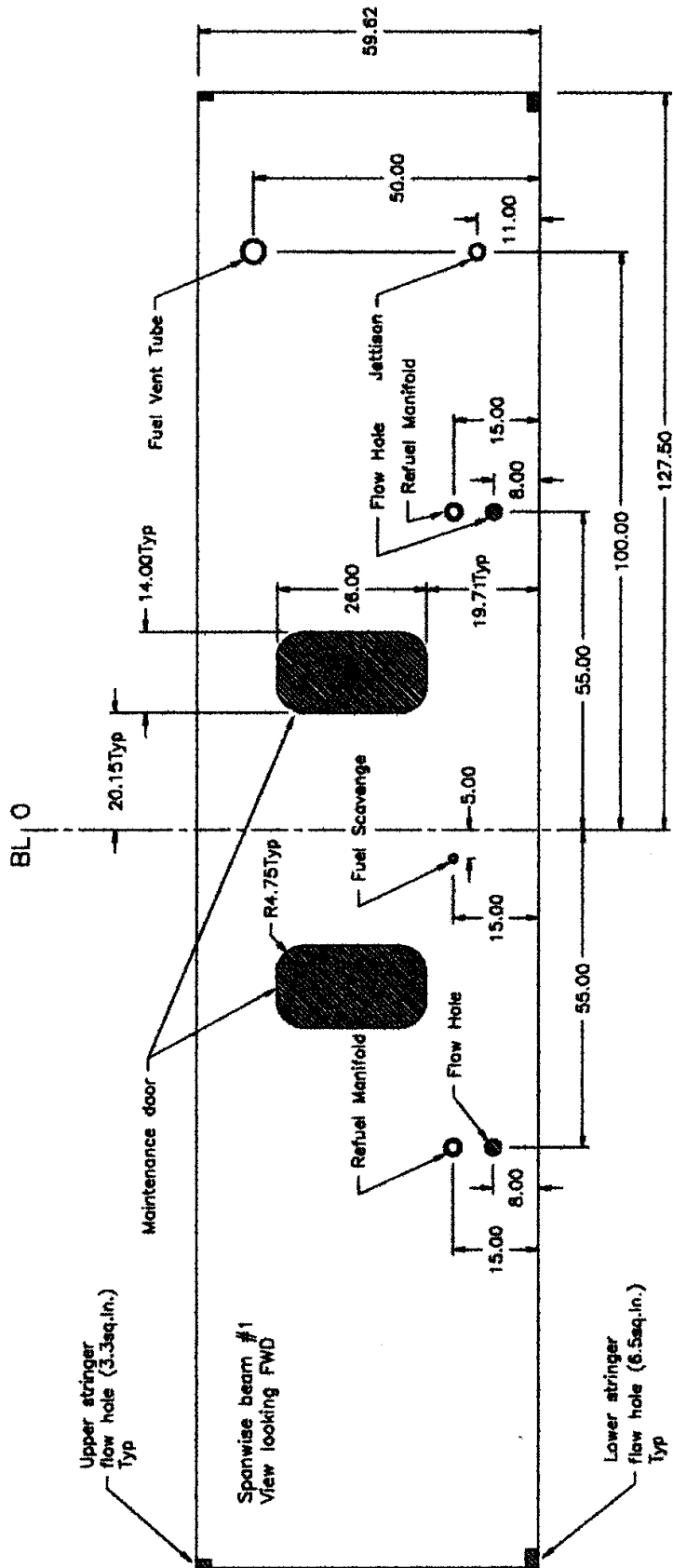

FIGURE A-6. FRONT VIEW OF SPANWISE BEAM 1 OF 747-100/SP CENTER WING TANK ILLUSTRATING SPANWISE BEAMS AND SPARS

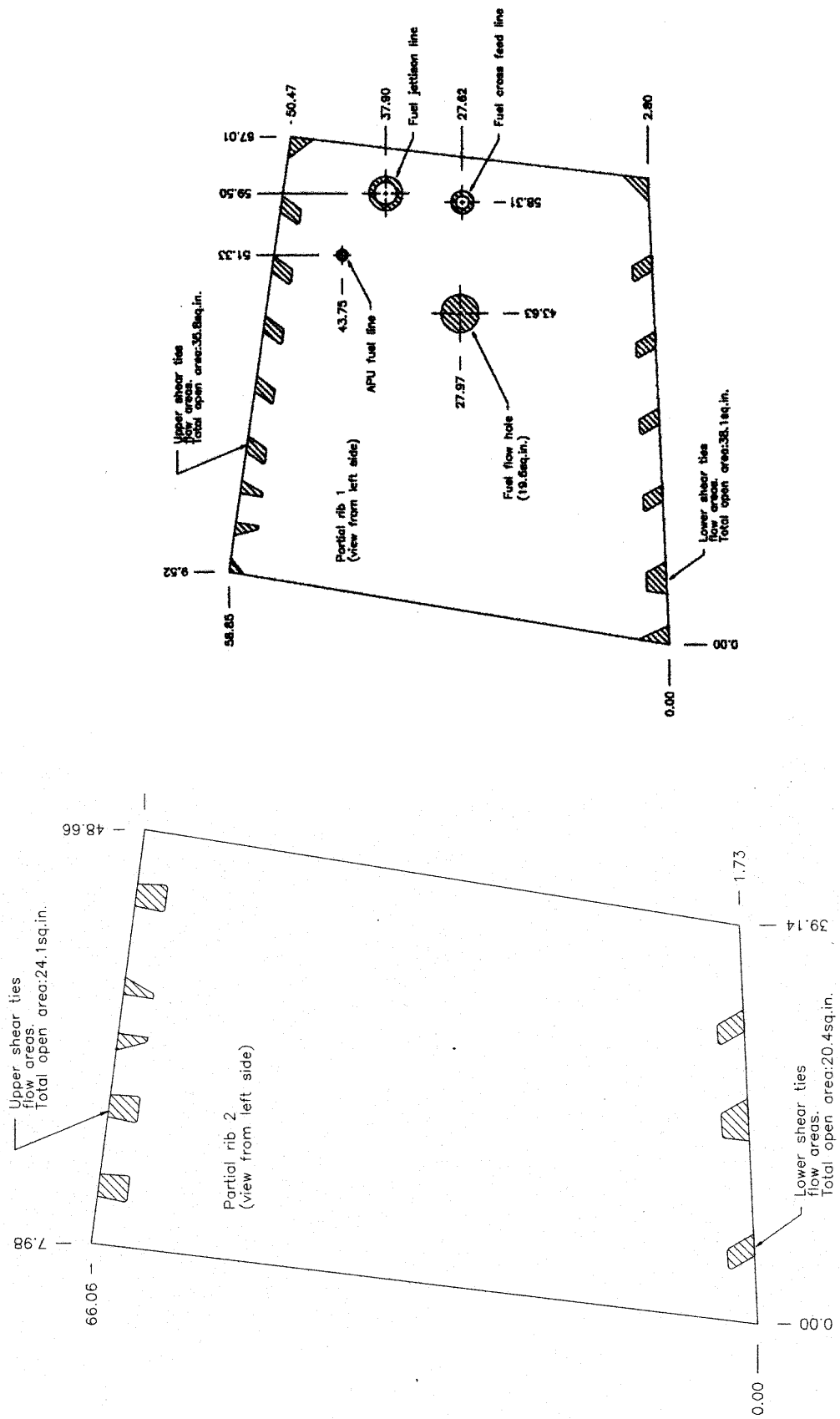

FIGURE A-7. VIEW OF BOTH PARTIAL RIBS OF 747SP CENTER WING TANK; BETWEEN SPANWISE BEAM 1 AND MIDSPAR (LEFT), AND BETWEEN REARSPAR AND SPANWISE BEAM 1 (RIGHT)

TABLE A-1. SUMMARY OF FLOW AREAS BETWEEN CWT BAYS

SWB1 Penetration Areas (between bays 3&5 and 4&6)					
	Flow Area (sq. in)	Scaled Area (sq. in)	Hole Drilled (inches)	Actual Area (sq. in)	Quantity
Lower Stringer Flow Area	6.5	0.3744		0.375	2
Upper Stringer Flow Area	3.3	0.19008		0.25	2
Fuel Vent	4.57	0.263232		0.24	1
Refuel Manifold	3.93	0.226368	0.5	0.196349541	2
Jettison	1.96	0.112896	0.375	0.110446617	1
Scavenge	0.98	0.056448	0.25	0.049087385	1
Flow Hole	5.94	0.342144	0.6875	0.371223351	2
Totals =	46.85	2.69856		2.784679785	
				Percent Difference = 3.19%	
				Area from 3 to 5 = 1.241660277	
				Area from 4 to 6 = 1.543019508	
MidSpar Penetration Areas (between bays 2&3 and 2&4)					
	Flow Area (sq. in)	Scaled Area (sq. in)	Hole Drilled (inches)	Actual Area (sq. in)	Quantity
Lower Stringer Flow Area	6.5	0.3744		0.375	2
Upper Stringer Flow Area	3.3	0.19008		0.25	2
Fuel Vent	4.57	0.263232		0.24	2
Refuel Manifold	5.3	0.30528	0.625	0.306796158	2
Scavenge	0.98	0.056448	0.25	0.049087385	1
Flow Hole	5.03	0.289728	0.625	0.306796158	2
Totals =	50.38	2.901888		3.006272016	
				Percent Difference = 3.60%	
				Area from 2 to 3 = 1.5276797	
				Area from 2 to 4 = 1.478592315	
SWB2 Penetration Flow Areas (between bays 1&2)					
	Flow Area (sq. in)	Scaled Area (sq. in)	Hole Drilled (inches)	Actual Area (sq. in)	Quantity
Lower Stringer Flow Area	5.3	0.30528		0.375	2
Upper Stringer Flow Area	3.3	0.19008		0.25	2
Fuel Vent	4.57	0.263232		0.24	2
Refuel Manifold	5.3	0.30528	0.5	0.196349541	2
Flow Hole (scavenge)	1.77	0.101952	0.125	0.012271846	1
Totals =	38.71	2.229696		2.134970928	
				Percent Difference = 4.25%	

TABLE A-1. SUMMARY OF FLOW AREAS BETWEEN CWT BAYS (Continued)

Partial Rib1 Between RS and SWB1 Penetration Areas (between bays 5&6)				
	Flow Area (sq. in)	Scaled Area (sq. in)	Hole Drilled (inches)	Actual Area (sq. in)
Lower Shear Ties Area	38.1	2.19456		2.19
Upper Shear Ties Area	35.8	2.06208		2.06
APU Fuel Line	0.98	0.056448	0.25	0.049087385
Crossfeed Line	4.66	0.268416	0.5625	0.248504888
Fuel Jettison Line	8.83	0.508608	0.8125	0.518485506
Flow Hole	19.6	1.12896	1.25	1.22718463
Total =	107.97	6.219072		6.293262409
		Percent Difference =		1.19%

Partial Rib 2 Between SWB1 and MS Penetration Areas (between bays 3&4)				
	Flow Area (sq. in)	Scaled Area (sq. in)	Hole Drilled (inches)	Actual Area (sq. in)
Lower Shear Ties Area	20.4	1.17504		1.18
Upper Shear Ties Area	24.1	1.38816		1.39
Total =	44.5	2.5632		2.57
		Percent Difference =		0.27%