

DOT/FAA/CT-91/2

FAA Technical Center  
Atlantic City International Airport  
N.J. 08405

# Development and Growth of Inaccessible Aircraft Fires Under Inflight Airflow Conditions

David Blake

February 1991

Final Report

This document is available to the U.S. public  
through the National Technical Information  
Service, Springfield, Virginia 22161



U.S. Department of Transportation  
Federal Aviation Administration

FSS000449R

FSS 000449 R -

02

NOTICE

This document is disseminated under the sponsorship of the U. S. Department of Transportation in the interest of information exchange. The United States Government assumes no liability for the contents or use thereof.

The United States Government does not endorse products or manufacturers. Trade or manufacturers' names appear herein solely because they are considered essential to the objective of this report.

1. Report No. DOT/FAA/CT-91/2	2. Government Accession No.	3. Recipient's Catalog No.	
4. Title and Subtitle DEVELOPMENT AND GROWTH OF INACCESSIBLE AIRCRAFT FIRES UNDER INFLIGHT AIRFLOW CONDITIONS		5. Report Date February 1991	6. Performing Organization Code
		8. Performing Organization Report No. DOT/FAA/CT-91/2	
7. Author(s) David Blake	9. Performing Organization Name and Address Federal Aviation Administration Technical Center Atlantic City International Airport, NJ 08405		10. Work Unit No. (TRAIS)
12. Sponsoring Agency Name and Address U.S. Department of Transportation Federal Aviation Administration Technical Center Atlantic City International Airport, NJ 08405		11. Contract or Grant No.	
		13. Type of Report and Period Covered  Final	
15. Supplementary Notes		14. Sponsoring Agency Code ACD-240	
		16. Abstract  The purpose of this project was to determine the likelihood of fire development and growth in accessible areas of an aircraft and the resulting hazards to cabin occupants from these fires. Numerous inflight fires or smoke events occur in accessible areas but are controlled by the crew or self-extinguish. Fatal inflight fires are rare events but originate in inaccessible areas. This project consisted of 57 tests of hidden inflight fires in a section of a DC-10 test article. The fires were started behind sidewall panels, below the cabin floor, above the cabin ceiling, in overhead stowage bins, in lavatory trash receptacles, and adjacent to lavatory flush motors. The conclusions were that (1) although uncontaminated insulation blankets did not readily support combustion, contaminated insulation blankets were found to support combustion (consistent with service experience); and (2) in this project and also consistent with actual service experience, the built-in Halon 1301 trash receptacle extinguishers did not always completely extinguish trash fires.	
17. Key Words Inaccessible Smoke Insulation Inflight Fire		18. Distribution Statement Document is available to the public through the National Technical Information Service, Springfield, Virginia 22161	
19. Security Classif. (of this report) Unclassified	20. Security Classif. (of this page) Unclassified	21. No. of Pages 30	22. Price

## TABLE OF CONTENTS

	Page
EXECUTIVE SUMMARY	v
INTRODUCTION	1
Purpose	1
Background	1
DISCUSSION	4
Test Article	4
Ventilation	4
Instrumentation	4
TEST DESCRIPTION AND RESULTS	5
CONCLUSIONS	11
REFERENCES	

## LIST OF ILLUSTRATIONS

Figure		Page
1	Test Article Instrumentation--Top View	12
2	Test Article Instrumentation--Side View	13
3	Test Article Instrumentation--End View	14
4	Overheated Wire Bundle	15
5	Chafed Wire Bundle Behind Sidewall	16
6	Arcing Wires in Cheek Area	17
7	Smoke Levels in Cabin--Tests 20 and 21	18
8	Mid Cabin Smoke--Tests 23 and 24	19
9	Suitcase Ignited in Stowage Bin	19
10	Temperatures--Test 30	20
11	Mid Cabin Smoke--Test 29	20
12	Wire and Insulation Ignited Above Cabin Ceiling	21
13	Above Ceiling Average Temperature--Tests 31,32, and 33	22
14	Above Ceiling Average Smoke Level--Test 31,32, and 33	23
15	Mid Cabin Average Smoke Levels--Tests 31,32, and 33	24
16	Wire and Insulation Before and After--Test 31	25
17	Wire and Insulation Before and After--Test 32	26
18	Wire and Insulation Before and After--Test 33	27

## EXECUTIVE SUMMARY

The purpose of this project was to determine the likelihood of fire development and growth in inaccessible areas of an aircraft and the resulting hazards to cabin occupants from these fires. Numerous inflight fires or smoke events occur in accessible areas but are controlled by the crew or self-extinguish. Fatal inflight fires are rare events but originate in inaccessible areas. This project consisted of 57 tests of hidden inflight fires in a section of a DC-10 test article. The fires were started behind sidewall panels, below the cabin floor, above the cabin ceiling, in overhead stowage bins, in lavatory trash receptacles, and adjacent to lavatory flush motors. The conclusions were that (1) although uncontaminated insulation blankets did not readily support combustion, contaminated insulation blankets were found to support combustion (consistent with severe experience); and (2) in this project and also consistent with actual service experience, the built-in Halon 1301 trash receptacle extinguishers did not always completely extinguish trash fires.

## INTRODUCTION

### PURPOSE.

The purpose of this project was to experimentally determine the likelihood of fire development and growth in inaccessible areas of an aircraft and the hazards to cabin occupants from these fires.

### BACKGROUND.

Two inflight fires that resulted in fatalities are known to have occurred where the origin of the fire was inside or adjacent to a lavatory. The first accident of this type occurred in a Varig 707 in 1974 and resulted in 123 fatalities. Careless disposal of a cigarette into the trash chute was determined to be the probable cause of the fire. On June 2, 1983, an Air Canada DC-9 experienced an inflight fire which resulted in 23 fatalities. Although the exact cause of the fire was not determined, it is believed to have started in the area of the lavatory. In both of these incidents, the base or origin of the fires was not known and subsequent fire fighting techniques were not effective.

Over the last several years there have been several incidents of inflight fires onboard commercial aircraft that did not result in fatalities. The following are some examples of these:

In August of 1985, an Eastern Airlines 727 was forced to make an unscheduled landing after a fabric handbag laying against a cabin return air grille along the floor caught fire. The initial ignition and fuel sources were a book of matches and a leaking bottle of flammable hair spray, both in the handbag. Flames from the burning bag were drawn into the return air grille and caused partial burning of some aircraft parts including insulation blankets, return air grille parts, air-conditioning duct, underside of floor panels, and overhead cargo compartment liner. The fire was eventually extinguished by flight attendants using several hand-held extinguishers.

In March of 1988, a Northwest Airlines DC-10 had a fire in an electrical compartment below the cabin floor while taxiing to the gate after landing at Boston's Logan Airport. The fire apparently started when a battery ground cable arced and ignited some insulation blankets. After the passengers were quickly deplaned, fire department personnel entered the cabin and opened the cabin floor hatch above the electrical compartment. There was dense smoke in the cabin at this time and flames 1 to 2 feet high were observed in the electrical compartment. The fire department extinguished the fire by partially discharging a 17-pound Halon 1211 extinguisher into the compartment.

In April of 1988, a Continental 737 had a fire above the cabin ceiling while on final approach into Cleveland, Ohio. The fire was started when a fluorescent light ballast burned and ignited insulation blankets and foam air-conditioning duct insulation. The fire burned insulation blankets, damaged wire bundles, burned through the back of a stowage bin, and ignited a carryon bag inside the bin and burned some duct insulation. Smoke started to fill the cabin when an emergency evacuation was performed using all four evacuation slides. Fire department personnel extinguished the fire.

In December of 1989, an American West Airlines 737 had a fire in the unpressurized main gear wheel well area while on approach into Tucson, Arizona. The fire apparently resulted when a wire arced against a low pressure aluminum hydraulic line and the escaping stream of fluid ignited. The resulting fire burned through several other aluminum hydraulic lines causing the loss of all hydraulic system pressure. The airplane made a successful landing but was not able to stop and overran the runway. Fire department personnel extinguished the fire in the wheel well but nine people were injured during the emergency evacuation.

Another incident occurred on a Canadian Airlines' DC-10 in June of 1989 in the Netherlands. A fluorescent light socket above an aft lavatory apparently arced and ignited adjacent insulation batts. The fire spread to surrounding material including the lavatory ceiling, wire insulation, honeycomb panels separating the cabin from the area above the lavatory, and foam used as a seal above the honeycomb panels. A mechanic noticed the fire and fire department personnel extinguished the fire. There were no passengers aboard at the time. The subsequent investigation of this incident revealed the presence of lubricant from the passenger door drive chain on the insulation batts in that area.

The Federal Aviation Administration maintains a data base of Service Difficulty Reports (SDR's) for United States registered commercial airlines. For the time period between January 1984 to April 1990, the SDR's list 96 incidents of smoke or fire in lavatories. Table 1 gives a breakdown of the location and ignition source, if known, for those incidents. The majority of the incidents listed in table 1 under "Other" were from overheated flush motors.

Another cause of smoke in the cabin that appears often in the SDR's is overheated fluorescent light ballasts. For the same time period, the SDR's list 115 incidents of smoke in the cabin attributed to ballasts.

As of October 29, 1986, the FAA required that each lavatory in a passenger carrying transport category airplane be equipped with a smoke detector system that will provide a warning light or audio warning to the cockpit or cabin crew. In addition, the FAA also required as of April 29, 1987, that each lavatory in a passenger carrying transport category airplane be equipped with a built-in fire extinguisher for each waste disposal receptacle located within the lavatory. The built-in fire extinguisher must be designed to discharge automatically into each disposal receptacle upon occurrence of a fire in that receptacle. These built-in fire extinguishers are commonly referred to as "potty bottles" and generally use Halon 1301 as the agent. In February of 1990, a federal law went into effect that banned smoking on all commercial flights with a duration of under 6 hours. This effectively prohibited smoking on all commercial flights within the continental United States.



**TABLE 1. SERVICE DIFFICULTY REPORTS OF SMOKE IN LAVATORIES**

WITHOUT SMOKE DETECTORS			WITH SMOKE DETECTORS							
TRASH FIRE			TRASH FIRE				OTHER		SMOKING	
IGNITION BY CIGARETTES	IGNITION UNKNOWN	OTHER	IGNITION BY CIGARETTES		IGNITION UNKNOWN		OTHER		SMOKING	
			ALARM	NO ALARM	ALARM	NO ALARM	ALARM	NO ALARM	ALARM	NO ALARM
6	2	15	18	10	4	8	18	14	1	0

## DISCUSSION

### TEST ARTICLE.

The test article was a 43-foot aft section of a DC-10-30CF fuselage. The open ends of the fuselage were capped with an aluminum bulkhead. Aircraft flooring, sidewall panels, ceiling panels, and overhead stowage bins were installed in the cabin. Two surplus lavatories from a 707 were installed in the aft section of the fuselage. A partition was installed to separate the area behind and to the sides of the lavatories from the main cabin. A carbon dioxide extinguishing system was installed in the test article with nozzles in the main cabin, the above ceiling attic space, and the area behind the lavatories.

### VENTILATION.

To obtain information on cabin airflow patterns for incorporation into the DC-10 test article, inflight air velocity measurements were taken on board several passenger configured 747 and 767 aircraft. The measurements were taken at the air supply vents in the cabin ceiling, at the cabin outflow grilles along the lower sidewall, at several points along the cabin cross section, and in the lavatories. The air velocities that were measured in flight were duplicated in the test article by installing outflow valves and varying the openings, and by using a perforated plate on the supply fan. Ventilation was supplied to the cabin through two 10-inch-diameter perforated ducts connected to a large fan. The ducts were installed between the cabin ceiling and the sidewall stowage bins and ran the length of the fuselage. Air was forced through each duct at a rate of approximately 1400 feet per minute. This equated to approximately one change of cabin air every 4 minutes. One outflow valve was positioned on the aft underside of the fuselage. This valve provided the main outflow for cabin air that exited the cabin at the lower sidewall vents, flowed into the area between the cargo compartment and the outside skin, and then through the outflow valve. To simulate lavatory ventilation design, another outflow valve was connected to a plenum located behind the lavatories. Ducts were installed from the plenum to the toilet bowls and under the sink area of each lavatory. The valve opening was varied until the airflows through the lavatories equaled those measured in flight. The supply fan provided a slight positive pressure in the test article of approximately 0.02 pounds per square inch (psi) above ambient.

### INSTRUMENTATION.

Temperatures were measured with a total of 48 chromel-alumel type K thermocouples that were installed throughout the test article. Twelve thermocouples were in each lavatory in the open air spaces and in the cabinet under the sink. Six thermocouples were placed between sidewall panels and the fuselage outer skin in the right rear section of the test article. Six thermocouples were placed in the overhead attic space along the fuselage centerline, 1 foot below the top of the fuselage. A thermocouple tree with six thermocouples at 1-foot intervals was placed in the fuselage cabin. Six thermocouples were placed in the area between the cargo compartment and the outside aircraft skin, below floor level; three on the right side and three on the left side.

Smoke levels in the test article were measured with a total of 12 smoke meters. The smoke meters consisted of a collimated light beam incident on a photocell.

The smoke meters measured the reduction in light transmission over a 1-foot distance. Two banks of three smoke meters each were placed in the aircraft cabin, one in the front of the cabin and one in the middle. The smoke meters in each bank were equally spaced between the cabin floor and ceiling. Three smoke meters were placed in the right lavatory equally spaced between the floor and ceiling. Three additional smoke meters were installed in the overhead attic space, 1 foot below the top of the fuselage and equally spaced fore and aft.

Photoelectric smoke detectors manufactured by Gentex Corporation were installed in the right lavatory ceiling and in the area under the sink at the beginning of the test project. An additional Gentex detector was installed above the cabin ceiling in the aft section of the fuselage after test 8.

Carbon dioxide, carbon monoxide, oxygen, and either Halon 1211 or Halon 1301 concentrations were measured at four different points in the fuselage. Beckman Model 864 infrared analyzers were used for carbon dioxide and carbon monoxide. Beckman Model 865 infrared analyzers were used for Halon. Beckman Model OM-11EA analyzers were used for oxygen. The sampling point for these analyzers was at a height of 5 feet 7 inches, equally spaced along the cabin centerline. When fire tests were conducted in the lavatory, two of the sampling points were moved to the inside of the right lavatory, one in the cabinet under the sink and one in the open space of the lavatory. Figures 1, 2, and 3 give the top, side, and end views of the test article instrumentation.

All of the above instrumentation was connected to an analog-to-digital converter and then to a Tandy 1000 SX personal computer. Each data channel was recorded once every 5 seconds.

A Perkin-Elmer Industrial Central Atmosphere Monitoring System was also used to measure concentrations of combustion products. This system used a mass spectrometer and was capable of measuring the concentrations of oxygen, carbon dioxide, nitrogen, hydrogen fluoride, hydrogen cyanide, hydrogen bromide, hydrogen chloride, hydrogen sulfide, Halon 1211 and Halon 1301. The sampling points for this system were moved around the test article depending on where the fires were started.

Video and still cameras were placed in the test article to record and monitor the progression of the test fires.

#### TEST DESCRIPTION AND RESULTS

Ten inflight hidden fire scenarios were examined. They were:

1. Overheated wire bundles against insulation.
2. Simulated dry arc tracking behind sidewall.
3. Arcing wires against insulation in cheek area.
4. Ignition of rigid foam ventilation duct under floor.
5. Fuel soaked rags ignited in bottom of cheek area.
6. Overheated ballast under stowage bin.
7. Suitcase ignited in overhead stowage bin.
8. Above ceiling fires of wire and insulation batts.
9. Lavatory trash receptacle fires.
10. Lavatory flush motor fires.

## 1. Overheated Wire Bundles Against Insulation (Tests 1-6)

In this scenario a 3-foot section of a wire bundle with a length of nichrome wire added to the bundle was attached to the test article between the lavatory wall and the aircraft skin. Several fiberglass insulation batts were placed between the wire bundle and the outside skin as in figure 4. Current was passed through the nichrome wire to heat it and the wire bundle. Five different types of Orcon Corporation insulation covers were tested in this scenario. They were An-22 aluminized Tedlar™, AN-19 aluminized Tedlar, AN-4C aluminized Tedlar, KN-80 polyimide Kapton™, and AN-26 polyester Mylar™. All test fires self-extinguished. The aluminized Tedlar and polyester Mylar coverings melted away from the wire bundle and were slightly burned in several areas. The polyimide Kapton covering only melted where it was in direct contact with the burnt wire bundle but did not burn. The smoke detectors did not alarm during any of these tests, and the smoke meters in the cabin did not measure any reduction in light transmission. Smoke and a strong burning smell were present in the test cell following these tests, but there was little or no smell inside the test article. The cabin ventilation system carried the smoke and fumes into the cheek area and then out the outflow valve into the test cell.

## 2. Simulated Dry Arc Tracking Behind Sidewall (Tests 7-11)

This scenario simulated a short in a bundle of Kapton insulated wire caused by chafing and the subsequent dry arc tracking that occurs when the circuit breakers are reset. Kapton is a highly thermally resistant material and is the most common aircraft wiring insulation. However, Kapton has a greater propensity for arc tracking than other types of wiring insulation, and it produces the most intense arc should arc tracking occur (references 1 and 2). A bundle of Kapton insulated wire was placed behind a cabin sidewall panel with a fiberglass insulation batt (with an aluminized Tedlar covering) between the wire bundle and the aircraft skin and another batt between the wire bundle and the sidewall panel. A reciprocating saw with a small file in place of the blade was attached to the sidewall panel and used to chafe the wire bundle. Figure 5 shows the configuration for this test scenario. The wire bundle consisted of 7 wires. Two wires were connected to each phase of a 220-volt, three-phase power supply with the seventh wire connected to ground. Each of the hot wires were protected by a 10-amp aircraft type circuit breaker. The test procedure was to energize the wire bundle and then chafe it with the saw until an arc occurred and a circuit breaker tripped. The breaker was reset which usually resulted in an additional arc and tracking to another wire in the bundle. The breakers were continually reset until arcing no longer occurred. The aluminized Tedlar insulation cover melted and burned away from the area of arcing and then quickly self-extinguished in tests 7, 9, 10 and 11. In those tests, the smoke detectors in the lavatory did not alarm and the smoke meters in the cabin and above the cabin ceiling recorded negligible levels of reduction in light transmission. In test 8, the arcing ignited the insulation cover which burned up to the bottom of the window and then self-extinguished. The decorative coating on the cabin side of the aluminum sidewall panel started to melt and peel away. Both of the lavatory smoke detectors alarmed at 11 minutes 34 seconds into the test. The lowest light transmission level measured in the cabin was 92 percent. This was measured by the smoke meter 72 inches from the floor in mid cabin. There was a negligible increase in cabin temperature and gas (CO, CO<sub>2</sub>) levels.

### 3. Arcing Wires Against Insulation in Cheek Area (Tests 12,13,16,19,20,21)

This scenario simulated an arcing wire against an insulation batt in the cheek area. Fiberglass insulation with aluminized Tedlar covering was placed against the aircraft skin in the cheek area from the bottom of the cargo sidewall to the bottom of the cabin floor. Wires connected to a 220-volt, three-phase power supply were taped against the insulation batts and shorted together. Figure 6 shows the configuration for this test scenario. Tests 12, 13, and 16 used uncontaminated insulation covers. In these tests the arcs burned holes through the covers and the fiberglass insulation. The aluminized Tedlar covers were ignited by the arc, and small flames continued to burn for several minutes before self-extinguishing. Smoke detectors in the lavatory did not alarm, and smoke meters in the cabin measured only negligible smoke levels.

Tests 19, 20, 21 used the same configuration as the previous tests except that the insulation blankets were contaminated with Holt Lloyd Corporation's LPS-3 heavy duty rust inhibitor. This product is a spray used by some airlines as a corrosion inhibitor in the bilge area. In test 19, LPS-3 was sprayed onto the aircraft aluminum behind the insulation blankets. The insulation blankets were then put back in position allowing them to come in contact with the LPS-3. The LPS-3 was allowed to dry for 6 days before the test was conducted. Test results were similar to tests 12, 13, and 16 where the batts were not contaminated. In test 20, LPS-3 was sprayed directly onto both sides of the insulation batts and allowed to dry for 1 day. The arcs ignited two of the three insulation batts and after burning for several minutes; all three batts fell down into the bottom of the cheek area and were completely consumed in the fire. The photoelectric smoke detector above the cabin ceiling alarmed at 4 minutes, and the smoke detector in the lavatory under the sink area alarmed at 6 minutes. In test 21, LPS-3 was again sprayed directly onto both sides of the insulation batts and dried for 1 day. The galvanized metal cargo liners adjacent to the insulation batts were replaced with fiberglass cargo liners for this test. The first arc ignited the batts and all three were completely consumed in the fire. The fire burned off the resin in approximately a 1-foot diameter section of the fiberglass liner. This contributed more smoke to the cabin as can be seen by figure 7 which shows the average of the three smoke meters in the mid cabin for tests 20 and 21.

### 4. Ignition of Rigid Foam Ventilation Duct Under Floor (Tests 14,15,17,18)

This scenario simulated an overheated wire against a ventilation duct. The ventilation duct was from a Boeing 727 and consisted of a rigid foam core covered with fiberglass. The duct was installed in the upper cheek area, just below the cabin floor. A small fan forced air from the cheek area through the duct and into a riser that directed the air into the cabin. In tests 14 and 17, a length of nichrome wire was placed inside of the duct and energized. In test 14, there was very little burning of the duct and a light haze of smoke in the cabin. None of the smoke detectors alarmed. In test 17, the duct ignited and burned for several minutes. The lavatory ceiling and under the sink smoke detectors alarmed approximately 20 minutes into the test and remained on for approximately 4 minutes. In tests 15 and 18, the nichrome wire was wrapped around the outside of the ventilation duct. There was very little burning of the duct in both of these tests and a light haze of smoke appeared in the cabin. None of the smoke detectors alarmed for either of these tests.

## 5. Fuel Soaked Rags Ignited in Bottom of Cheek Area (Tests 22-25)

This scenario simulated a fire in the lower cheek area that could be caused by fuel soaked insulation blankets or a hydraulic fluid fire. In test 22, 200 milliliters (mL) of fuel oil was poured onto some rags in the bottom of the cheek area. Three batts of insulation covered with aluminized Tedlar were installed against the aircraft skin above the rags, and fiberglass cargo liners were installed adjacent to the rags. One insulation batt directly above the burning rags was ignited and fell down into the bottom of the cheek area where it was completely consumed in the fire. The cargo liner adjacent to the fire was scorched and some of the resin was burned off. The fire burned for approximately 20 minutes before self-extinguishing. The smoke detectors in the lavatory and above the cabin ceiling alarmed and remained on until the doors in the test article were opened after the test. In test 23, 400 mL of fuel oil were used and all other conditions were the same as test 22. The results of test 23 were similar to test 22.

Test 24 and 25 used the same initial conditions as test 23. In these tests however, the cabin ventilation system was turned off and the outflow valve was closed as soon as the first smoke detector alarmed. In both tests, the first smoke detector to alarm was the photoelectric detector under the sink in the lavatory. This occurred at 4:12 in test 24 and 4:00 in test 25. Figure 8 is a graph of the smoke meter data in the cabin for tests 23 and 24 and shows that ventilation shutoff increased cabin smoke levels.

## 6. Overheated Ballast Under Stowage Bin (Tests 26-28)

This scenario was an attempt to simulate the ballast fire in the Continental 737 which was described earlier in this report. A fluorescent light ballast was installed under a stowage bin where it would normally be in a DC-10. A small piece of fire-retarded polyurethane foam was placed next to the ballast, and aircraft insulation batts were installed against the outside skin. In all three tests the outputs of the ballasts were connected to ground and 220 volts AC were applied to the inputs. In tests 26 and 27, there was some smoke from the ballasts when power was first applied but the smoke dissipated quickly. In test 28, no smoke was visible but the outside of the ballast case reached 150 °F after several minutes. Prior to conducting these three full-scale tests on ballasts, 15 small-scale tests were conducted in an effort to determine the electrical connections necessary to cause the ballasts to overheat and burn. In three of these tests the potting material inside the ballast did ignite and burn. The ballasts were connected the same way in the full-scale tests but did not ignite in those three tests.

## 7 Suitcase Ignited in Overhead Stowage Bin (Tests 29 and 30)

In this scenario, a small suitcase was filled with rags and placed in a overhead stowage bin. Fiberglass insulation with aluminized Tedlar covering was installed between the stowage bin and the aircraft skin. A small quantity of alcohol was poured onto the rags, and the suitcase was ignited with nichrome wire. Figure 9 shows the configuration for these tests. In both tests, the top of the stow bin was burning within 1 minute of the start of the test. The fire completely destroyed the stow bin that the suitcase was in and damaged the bins on either side in both tests. In both tests, the thermocouple in the front of the cabin at the 6-foot level recorded a temperature rise of approximately 30 °F during the

test, and the maximum temperature measured by the thermocouples above the cabin ceiling was 175 °F. Figure 10 shows the temperature above the cabin ceiling and at the 6-foot level in the cabin for test 30. Light transmission was reduced to approximately 45 percent in mid cabin and to near zero above the cabin ceiling in both tests. Smoke levels in mid cabin for test 29 are shown in figure 11. The stowage bins used in this scenario were tested in the Ohio State University rate of heat release calorimeter. This is the flammability requirement, described in FAR 25.853, Appendix F, Part IV, for ceiling and sidewall panels, partitions, galleys, and overhead stowage bins that became effective in August of 1988. Although these stowage bins were removed from service prior to August 1988 and therefore were not required to pass this new flammability test, they did meet the criteria that were in effect from August 1988 to August 1990. The 2-minute total heat release was 86.34 kW\*min/m<sup>2</sup> and the peak heat release rate was 73.44 kW/m<sup>2</sup>. The criteria in effect from August 1988 to August 1990 were a maximum total heat release of 100 kW\*min/m<sup>2</sup> and a maximum peak heat release rate of 100 kW/m<sup>2</sup>. After August of 1990, the criteria became more stringent; i.e., a maximum total heat release of 65 and a maximum peak heat release rate of 65.

#### 8. Above Ceiling Fires of Wire and Insulation Batts (Tests 31-33)

This scenario exposed three different combinations of wire bundles and insulation batts to a pan of burning alcohol above the cabin ceiling. The purpose of these tests was to evaluate the hazards introduced into the cabin from a relatively small amount of burning material. The three combinations of materials were Kapton insulated wire bundles against Kapton covered fiberglass insulation (test 31); polyvinyl chloride (PVC)/nylon insulated wire bundles against aluminized Tedlar covered fiberglass insulation (test 32); and Tefzel (ethylene tetra fluoro-ethylene) insulated wire bundles against aluminized Tedlar covered fiberglass insulation (test 33). Four wire bundles of twenty 22-gauge wires each were used in each test. Two insulation batts were installed against the aircraft outer skin, and the wire bundles were installed against the insulation batts. A pan of alcohol was positioned at the bottom of the insulation batts just above the cabin ceiling. Figure 12 shows the test configuration for this scenario.

Test 32, with PVC wire and aluminized Tedlar insulation batts, produced significantly more smoke and heat than tests 31 and 33. Figure 13 shows the average temperature above the cabin ceiling for the three tests. The temperature is the average of the six thermocouples in the 950-cubic-foot space above the ceiling. Figures 14 and 15 show the average smoke levels for the three smoke meters above the ceiling and the three smoke meters in mid cabin. It can be seen from these graphs that the main source of smoke and heat in test 32 was from the PVC wire insulation, since test 33 used the same aluminized Tedlar insulation covering as test 32 but produced much less smoke and heat. A PVC/nylon wire insulation will not pass the current flammability test for aircraft wiring which was imposed in 1972. However, it was installed on some aircraft manufactured prior to that date, many of which are still in service. Kapton and Tefzel insulated wires do pass the current flammability test. Figures 16, 17, and 18 show the wire bundles and insulation before and after each of the three tests.

## 9. Lavatory Trash Receptacle Fires (Tests 34-41, 44-53)

This scenario looked at the effectiveness of Halon 1301 potty bottles and Halon 1211 hand-held extinguishers discharged through ports into confined spaces. Fires were ignited in the trash receptacle of the 707 lavatory by filling the receptacle with paper towels and newspaper and placing nichrome wire in either the top or bottom of the receptacle.

Five tests were conducted with the 1301 potty bottles, containing 0.23 pounds of agent, installed in the trash receptacle. The potty bottle discharged as designed in all five tests. In two of the tests, the fire was extinguished by the initial discharge of halon. In the remaining three tests, the fire was suppressed by the initial discharge but reignited after several minutes. The fires then burned for several more minutes before self-extinguishing after all the paper in the receptacle was consumed.

Eleven tests were conducted using a 2.5 pound halon 1211 hand-held extinguisher with a rating of 5-B:C. The initial test procedure was to discharge the extinguisher 1 minute after the nichrome wire was energized. This procedure was later changed to discharge the extinguisher 1 minute after the photoelectric smoke detector on the lavatory ceiling alarmed. The extinguisher was plumbed to discharge into specific areas. This setup simulated the use of a penetrator nozzle on the extinguisher or the use of pre-installed ports to discharge an extinguisher through. The lavatory door was kept closed for all tests.

Two tests were conducted with the extinguisher plumbed to discharge directly into the top of the trash chute. In one of those tests the initial discharge extinguished the fire. In the other test the initial discharge suppressed the fire but it reignited after several minutes. The backup CO<sub>2</sub> extinguishing system was used to extinguish this fire.

Four tests were conducted with the extinguisher plumbed to discharge into the bottom of the trash receptacle. In all four tests the initial discharge of agent extinguished the fire.

Five tests were conducted with the extinguisher plumbed to discharge through the lavatory door into the open space inside the lavatory. In three of these tests the initial discharge extinguished the trash fire. In one test the fire was suppressed by the initial discharge but then reignited after several minutes. The CO<sub>2</sub> extinguishing system was used to extinguish the fire. In the remaining test, no flames were visible after the initial discharge of halon; but upon inspection of the trash receptacle after the test, all the paper was found to be consumed.

## 10. Lavatory Flush Motor Fires (Tests 54-57)

This scenario was an attempt to simulate a fire caused by an overheated flush motor igniting surrounding material. A small quantity of newspaper was wrapped with nichrome wire and placed under the toilet shroud next to the flush motor. Two tests were conducted with a 2.5-pound Halon 1211 extinguisher plumbed to discharge through the lavatory door. The extinguisher was discharged 1 minute after the photoelectric smoke detector on the lavatory ceiling alarmed. The extinguisher suppressed the initial flames, but the fire continued to smolder in both tests until all of the newspaper was consumed. There was little damage to the toilet shroud.



One test was conducted with a 5-pound Halon 1301 extinguisher plumbed to discharge through the lavatory door. The extinguisher was discharged at the same time that the 1211 extinguisher was discharged in the previous test. The fire was suppressed for a short time and then reignited. The test was terminated at 5 minutes with the CO<sub>2</sub> extinguishing system.

One test was conducted with the newspaper ignited in the same way as previously ignited but no halon extinguisher was used. The fire spread up the inside and outside walls of the lavatory and burned through the lavatory ceiling. The lavatory was still burning at 10 minutes when the test was terminated with the CO<sub>2</sub> extinguishing system.

#### CONCLUSIONS

1. Aircraft ventilation systems can remove combustion products from a small fire in certain areas of the aircraft. This would allow small fires in these areas to burn without detection by cabin occupants.
2. Uncontaminated aluminized Tedlar covering on insulation batts melts away from sources of heat and does not readily support combustion.
3. Insulation blankets on inservice airplanes have been found to be contaminated with oily films, lubricant, fuel, and corrosion inhibitors. There have been cases where these blankets have been ignited by small ignition sources such as fluorescent light ballasts, arcing light sockets, and an arcing battery ground cable. In this project insulation blankets contaminated with a heavy duty rust inhibitor did support combustion.
4. A PVC/nylon insulated wire involved in a fire contributes significantly more smoke, heat, and hydrogen chloride to the cabin than Kapton or Tefzel insulated wire.
5. In this project and in actual service, lavatory trash receptacle built-in Halon 1301 fire extinguishers did not always completely extinguish trash receptacle fires, although all fires eventually self-extinguished and were contained within the trash receptacle.
6. Hand-held Halon 1211 extinguishers discharged directly into the bottom of the trash receptacle extinguished the trash receptacle fires in the four tests conducted with this scenario.
7. Hand-held Halon 1211 extinguishers discharged into the top of the trash chute suppressed but did not always extinguish the trash receptacle fires.
8. Hand-held Halon 1211 extinguishers discharged through the lavatory door into the open space inside the lavatory will suppress trash receptacle fires although the fire may later reignite.
9. Hand-held Halon 1211 and 1301 extinguishers discharged inside the lavatory suppressed but did not extinguish fires ignited in the area of the flush motor.

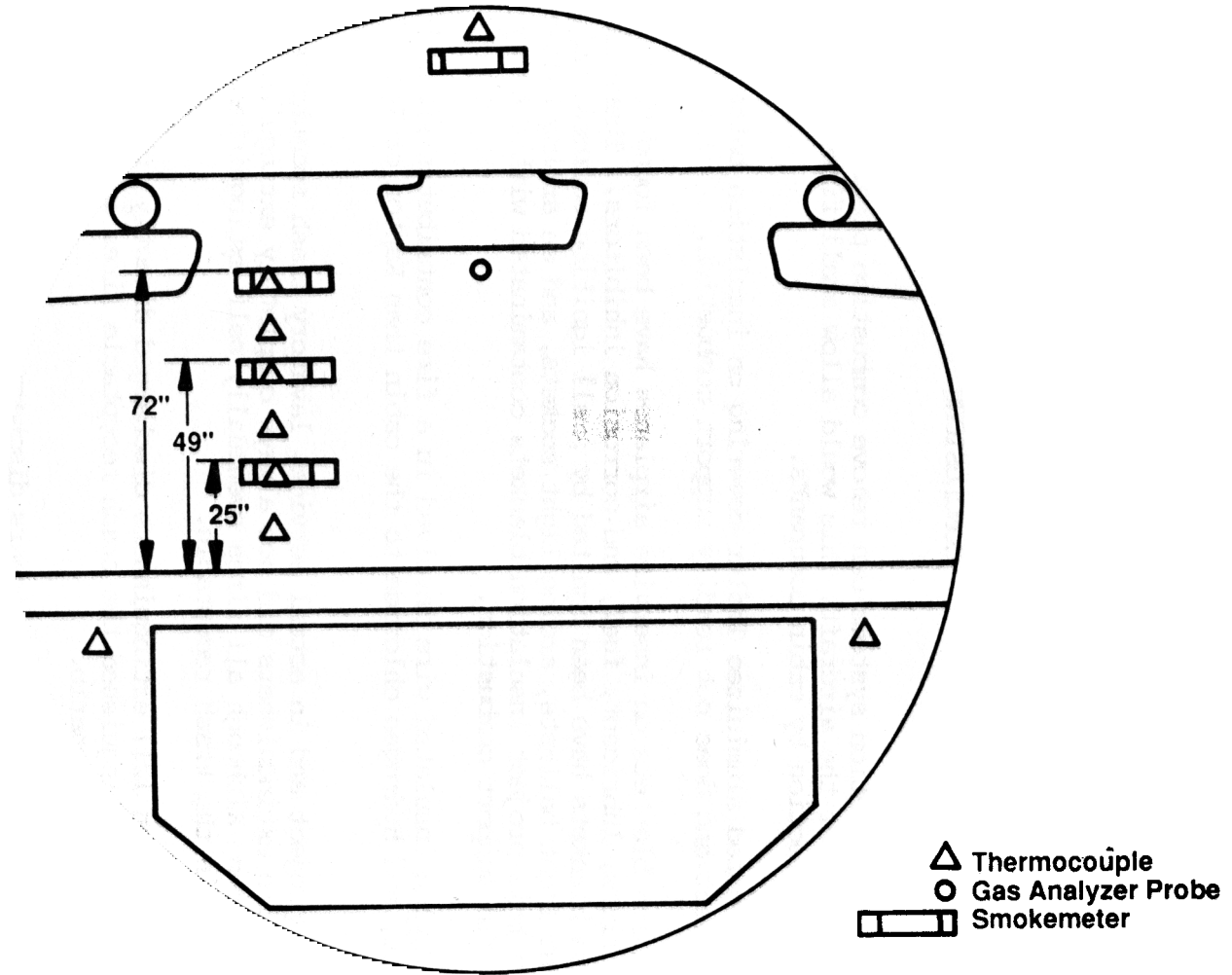

FIGURE TEST ARTICLE INSTRUMENTATION--TOP VIEW

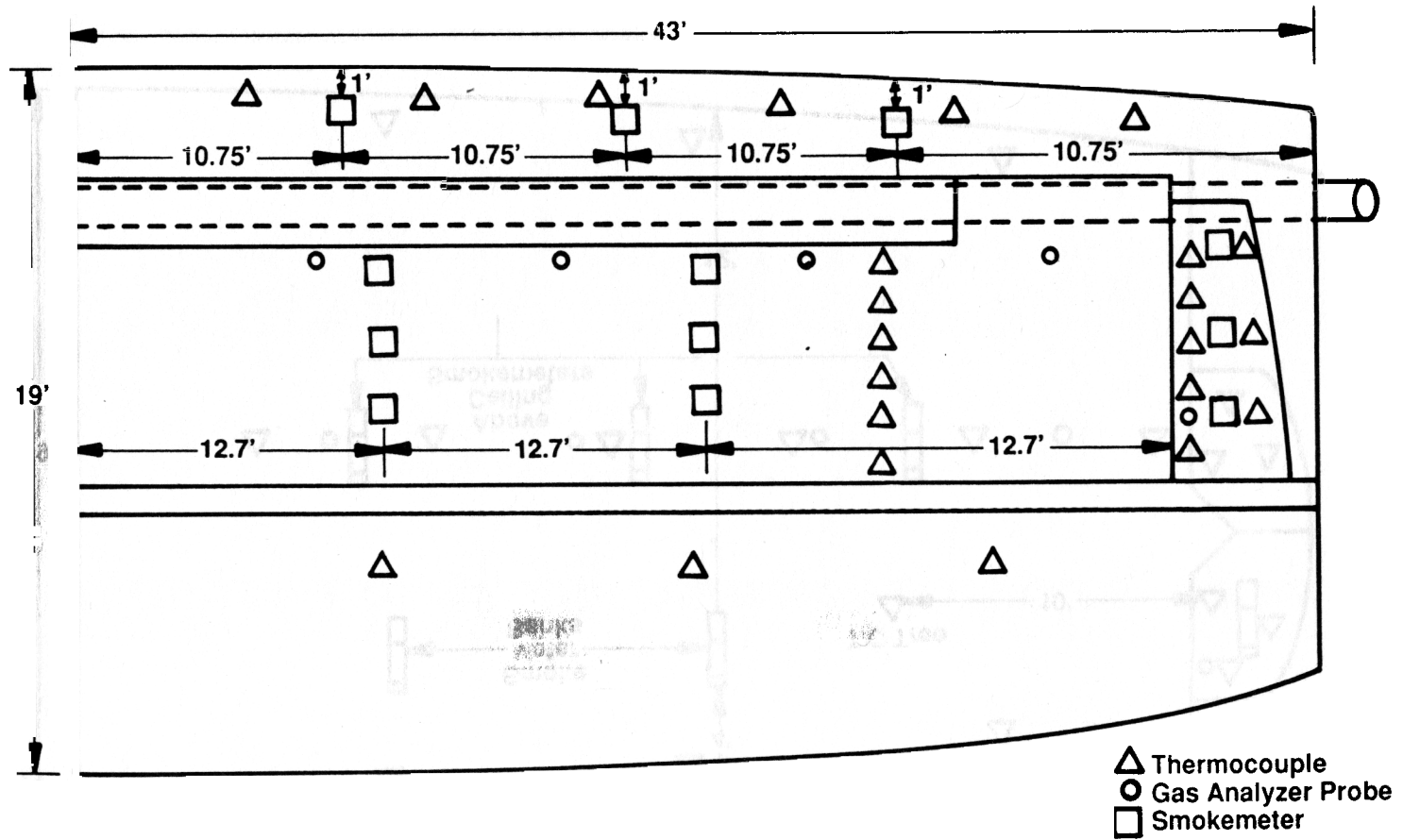

FIGURE 2. TEST ARTICLE INSTRUMENTATION--SIDE VIEW

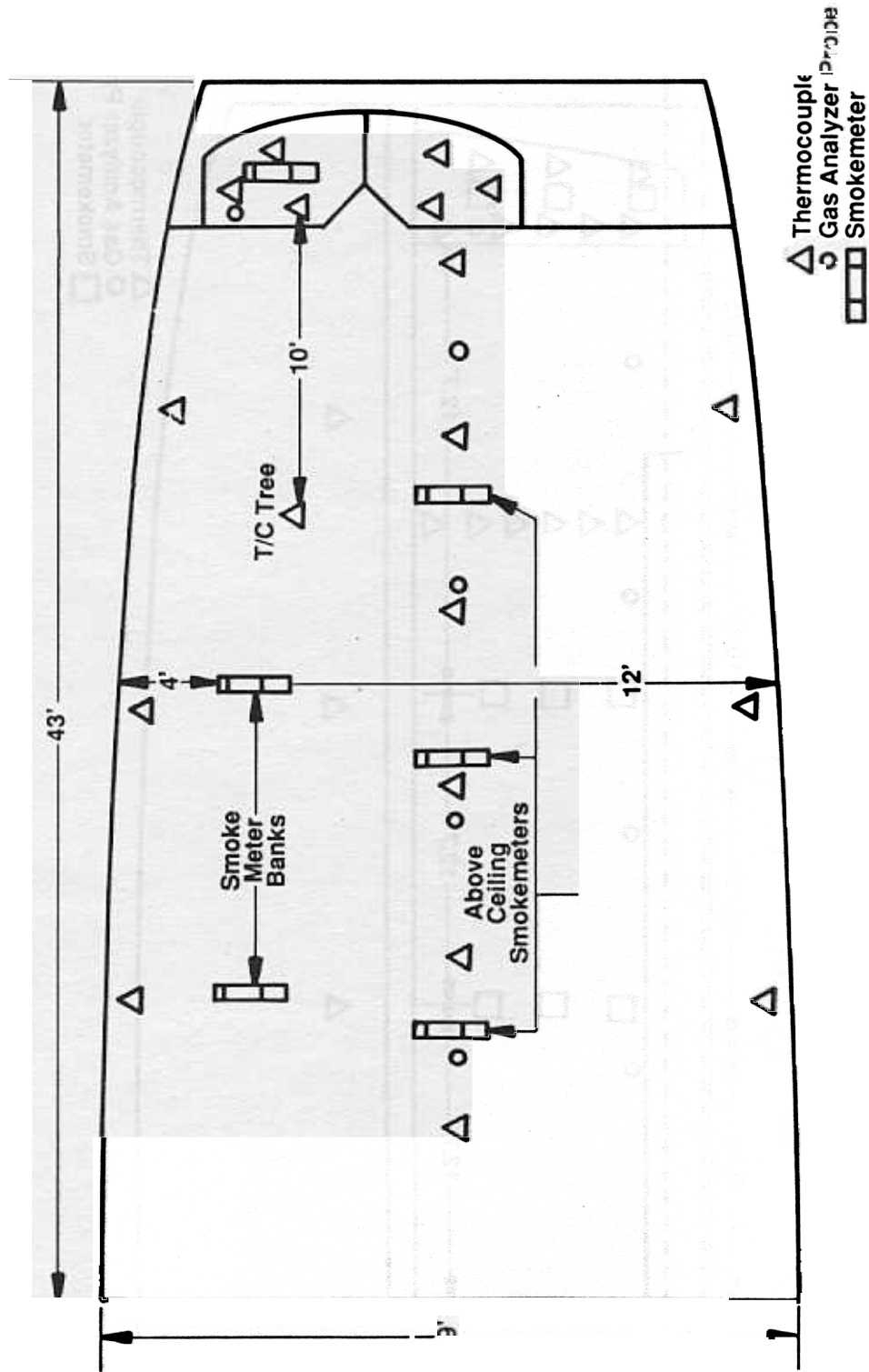

FIGURE INSTRUMENTATION—END VIEW

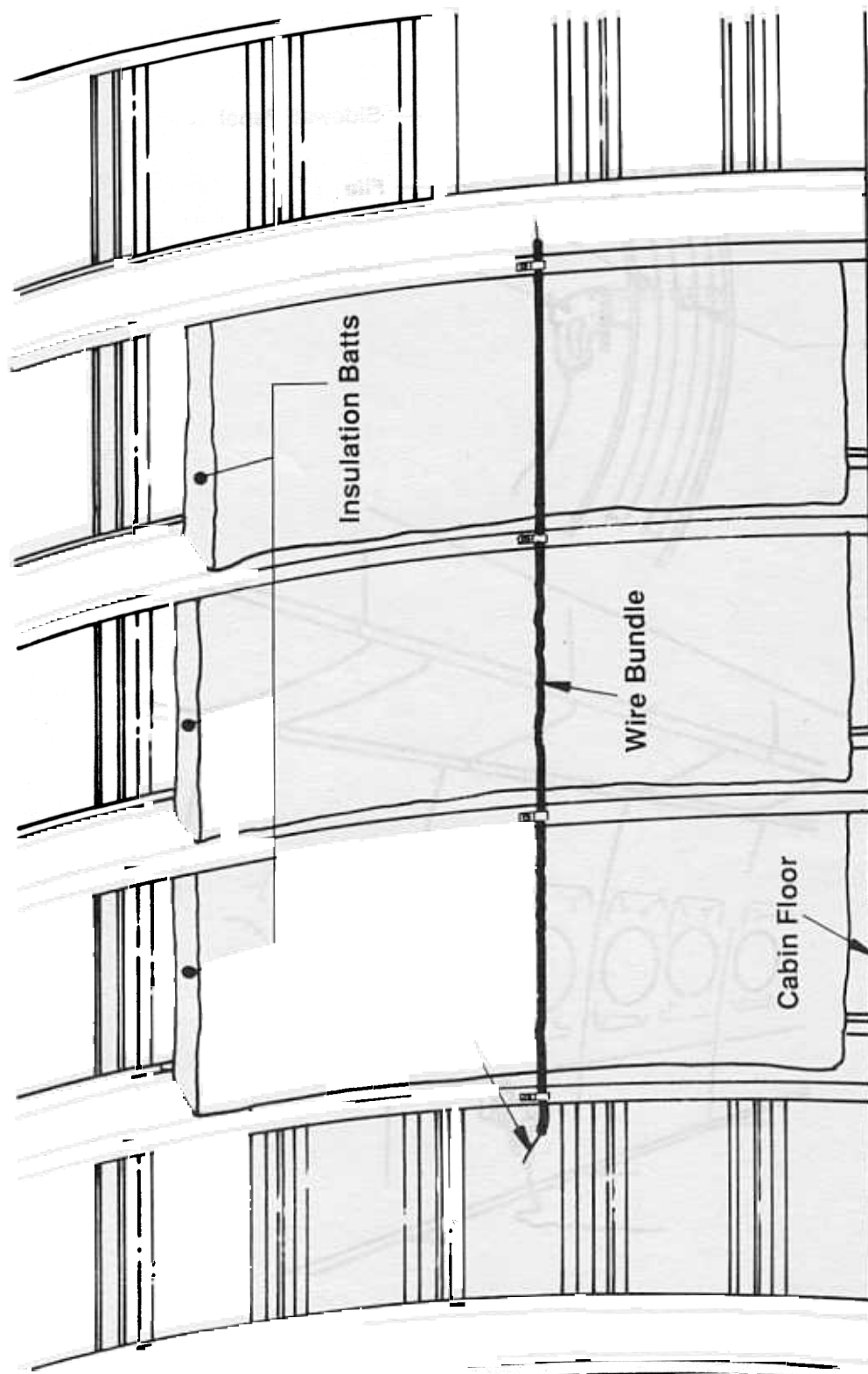

FIGURE 4. OVERHEATED WIRE BUNDLE

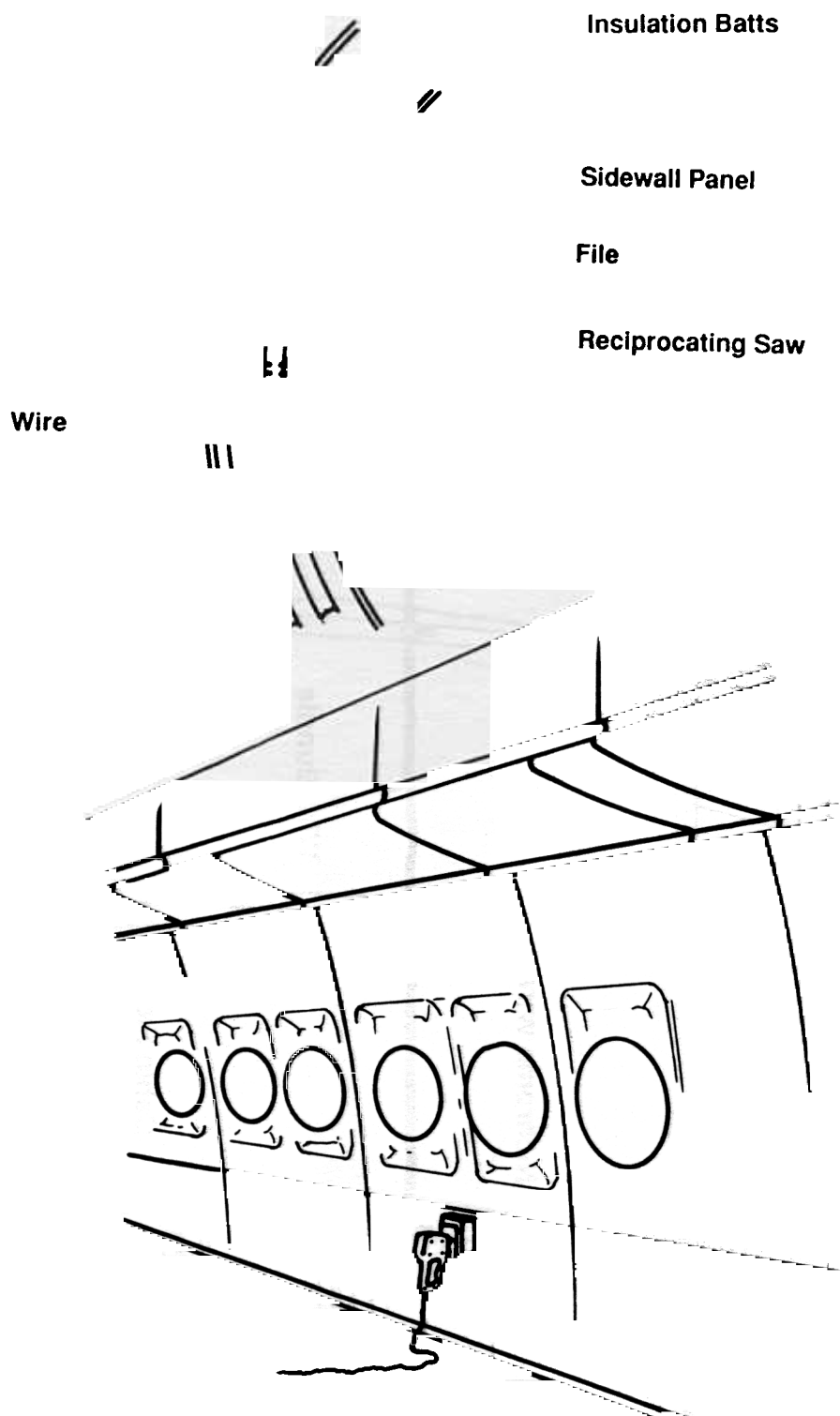

FIGURE 5. CHAFED WIRE BUNDLE BEHIND SIDEWALL

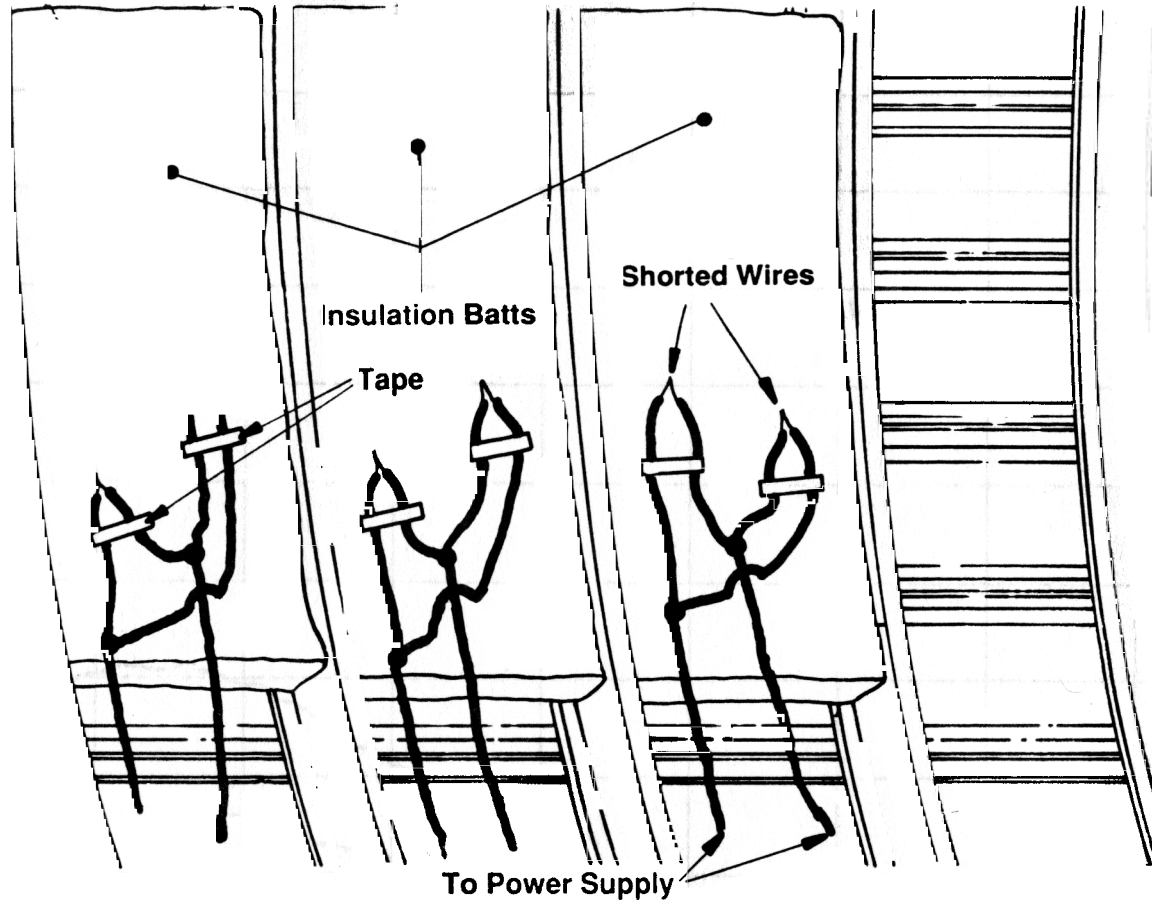

FIGURE 6. ARCING WIRES IN CHEEK AREA

— Test 20  
- - - Test 21

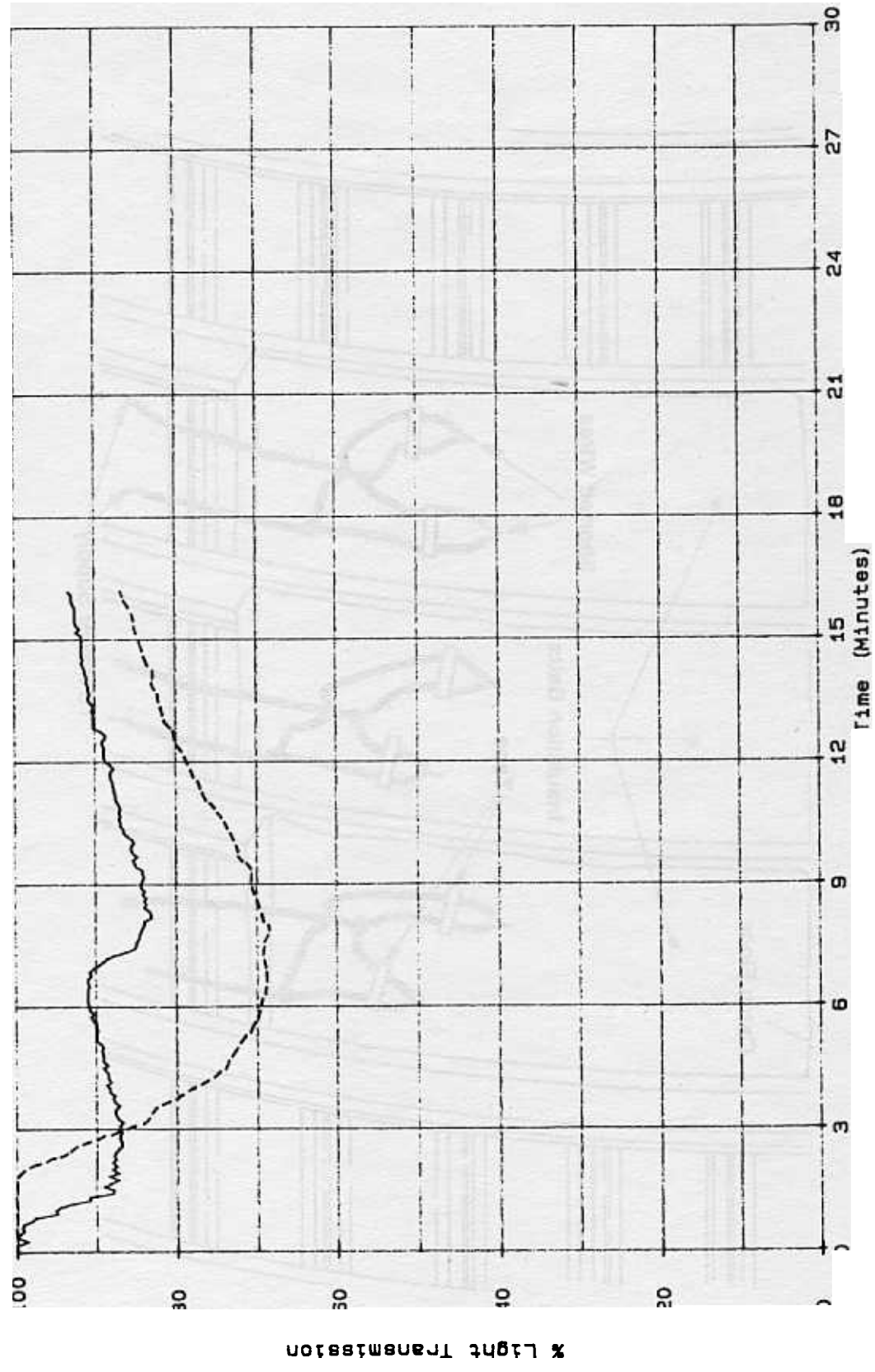
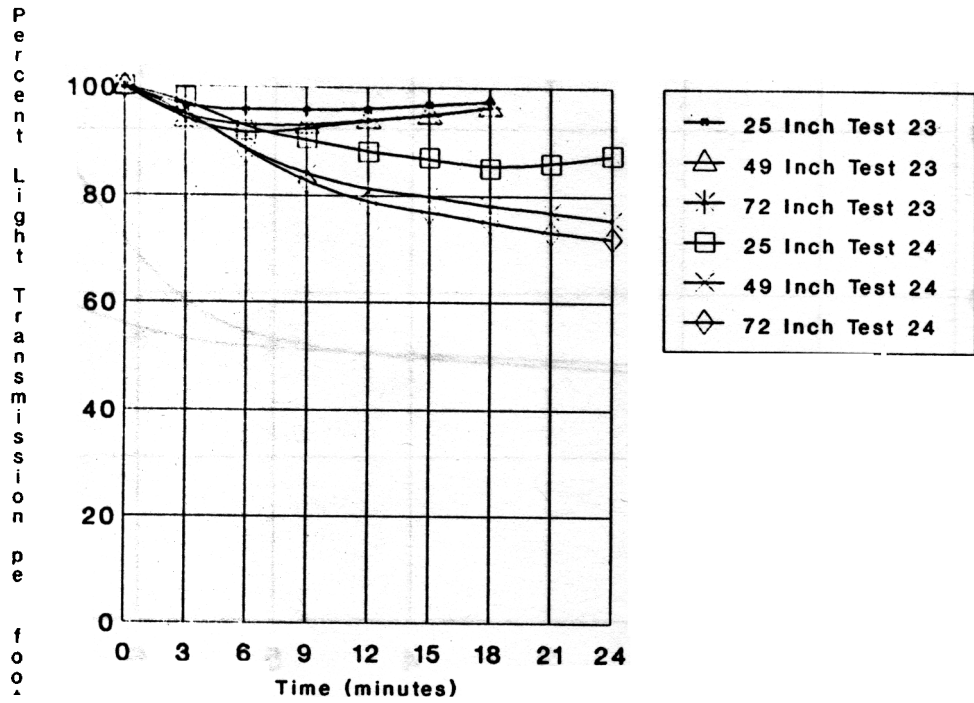

FIGURE 7. SMOKE LEVELS IN CABIN--TESTS 20 AND 21





•Ventilation turned off at 4:12 in test 24

FIGURE 8. MID CABIN SMOKE--TESTS 23 AND 24

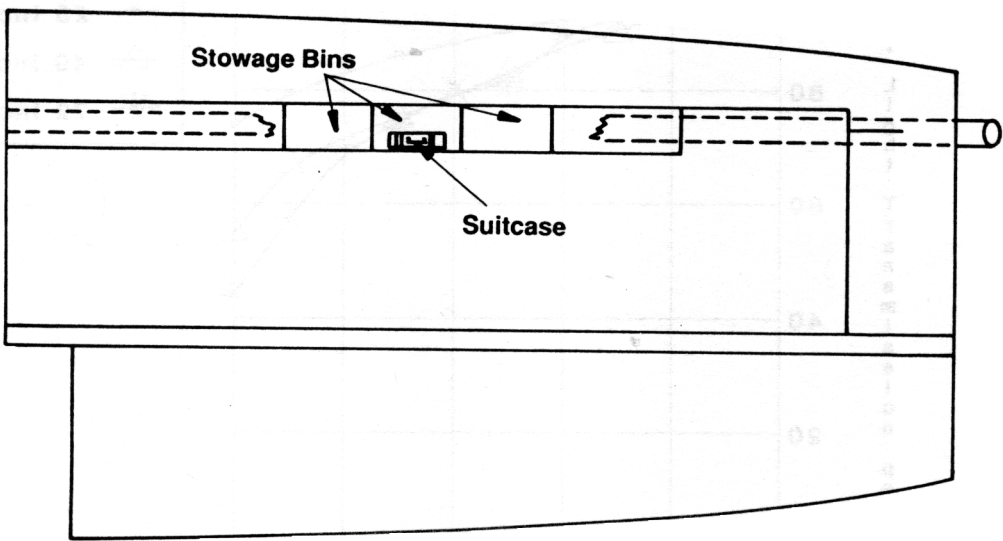

FIGURE 9. SUITCASE IGNITED IN STOWAGE BIN

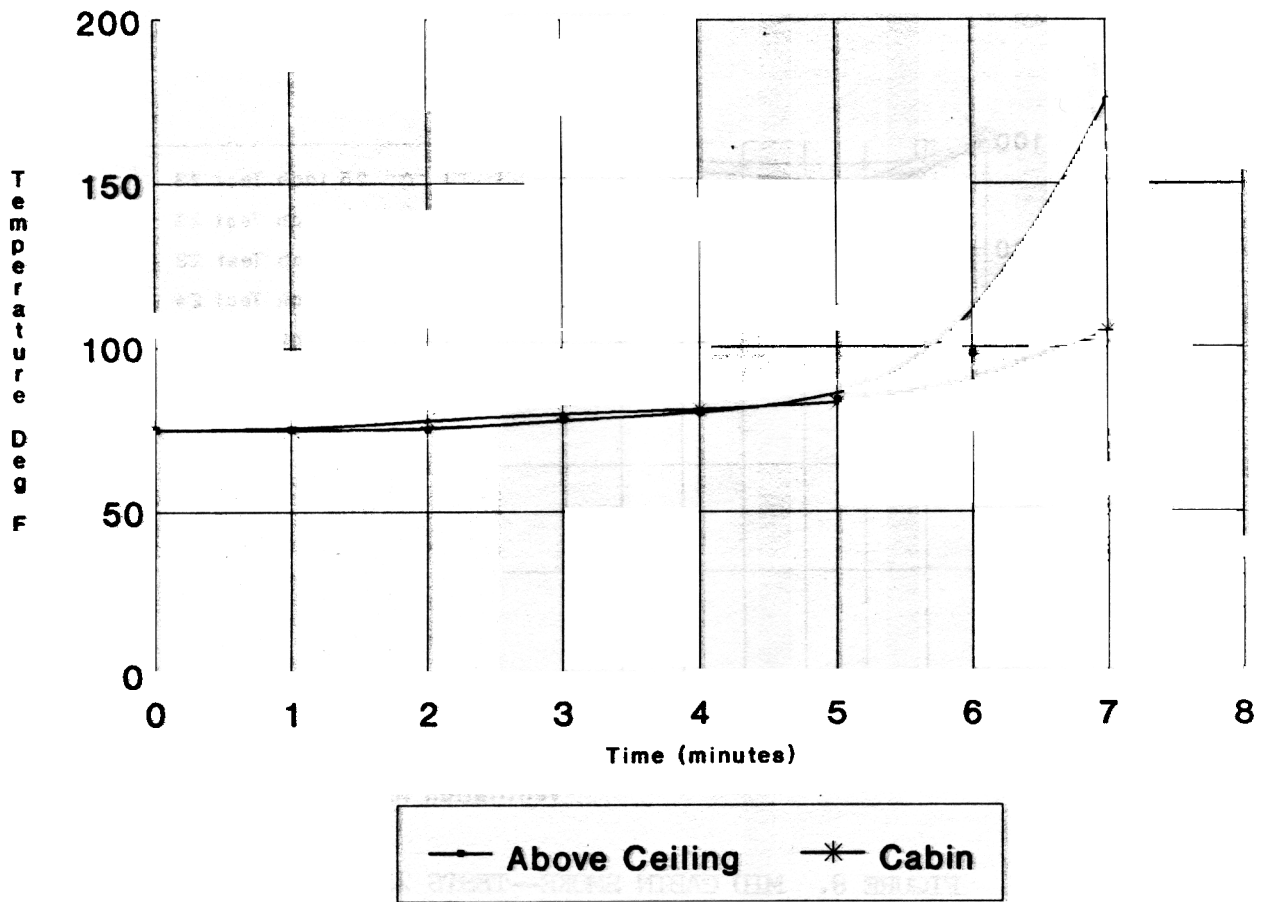

FIGURE 10. TEMPERATURES--TEST 30

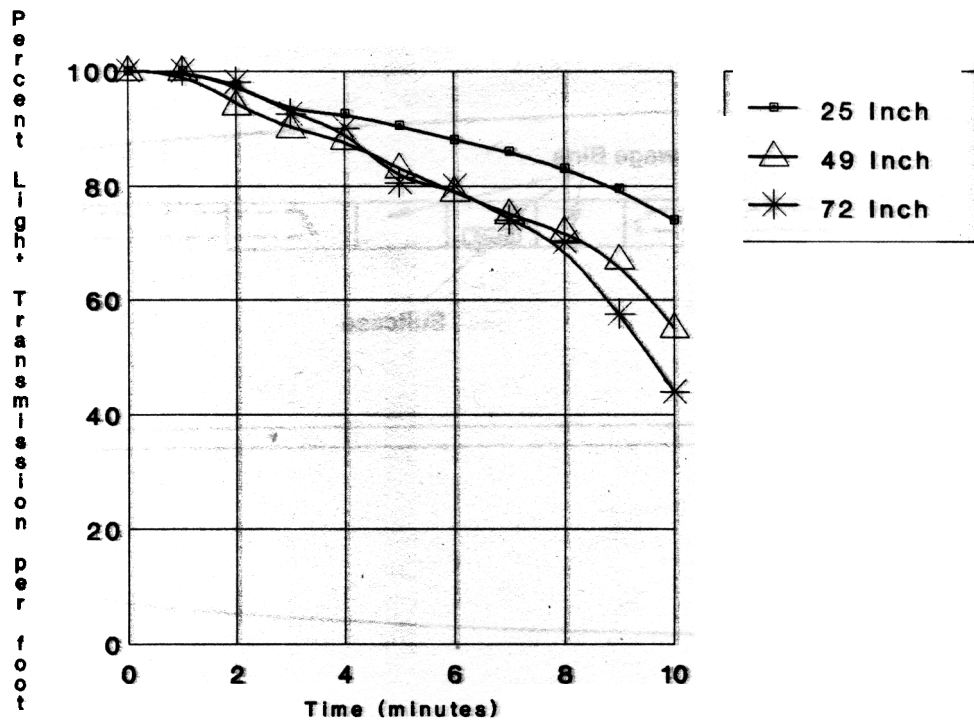

FIGURE 11. MID CABIN SMOKE--TEST 29

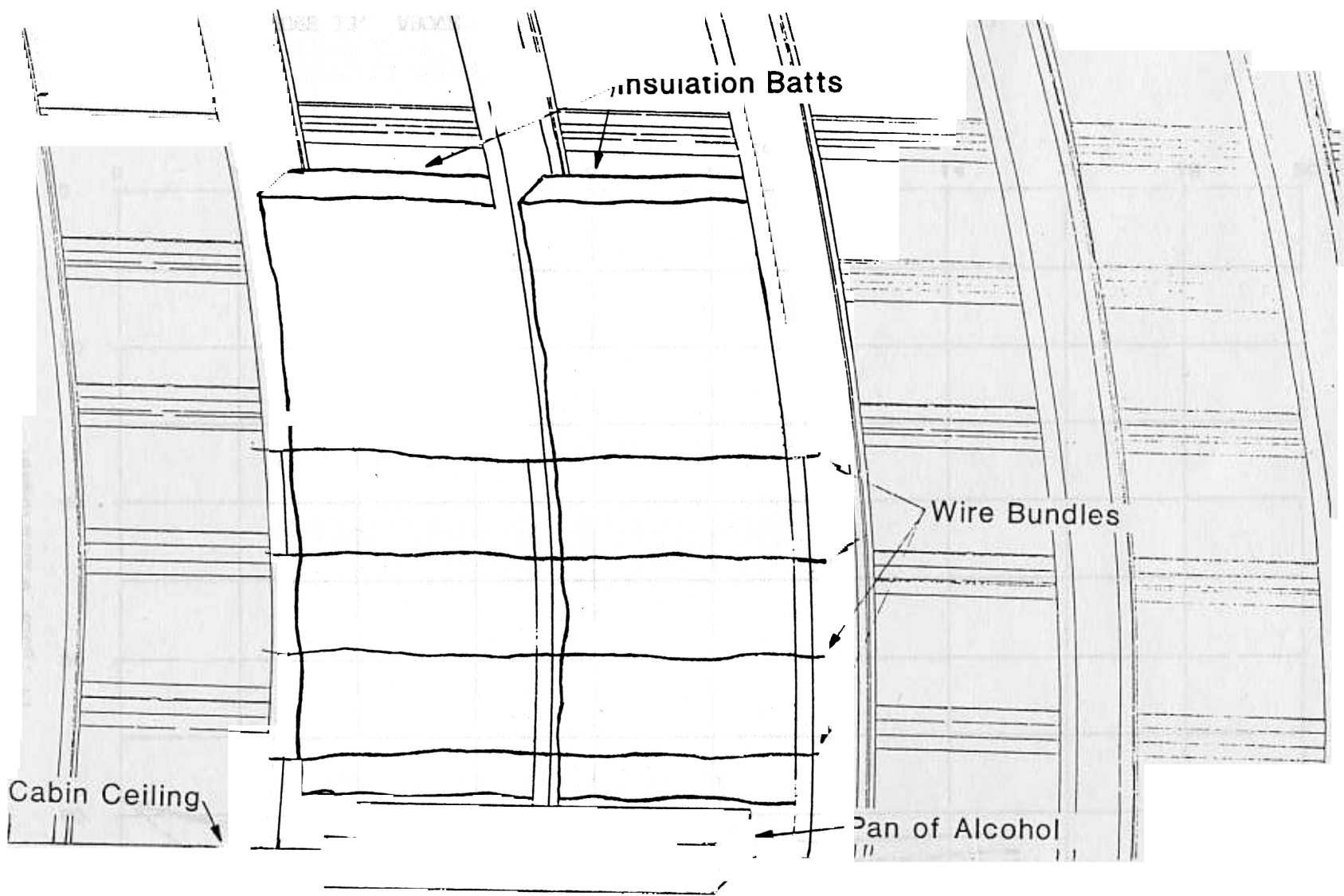

FIGURE 12. WIRE AND INSULATION IGNITED ABOVE CABIN CEILING

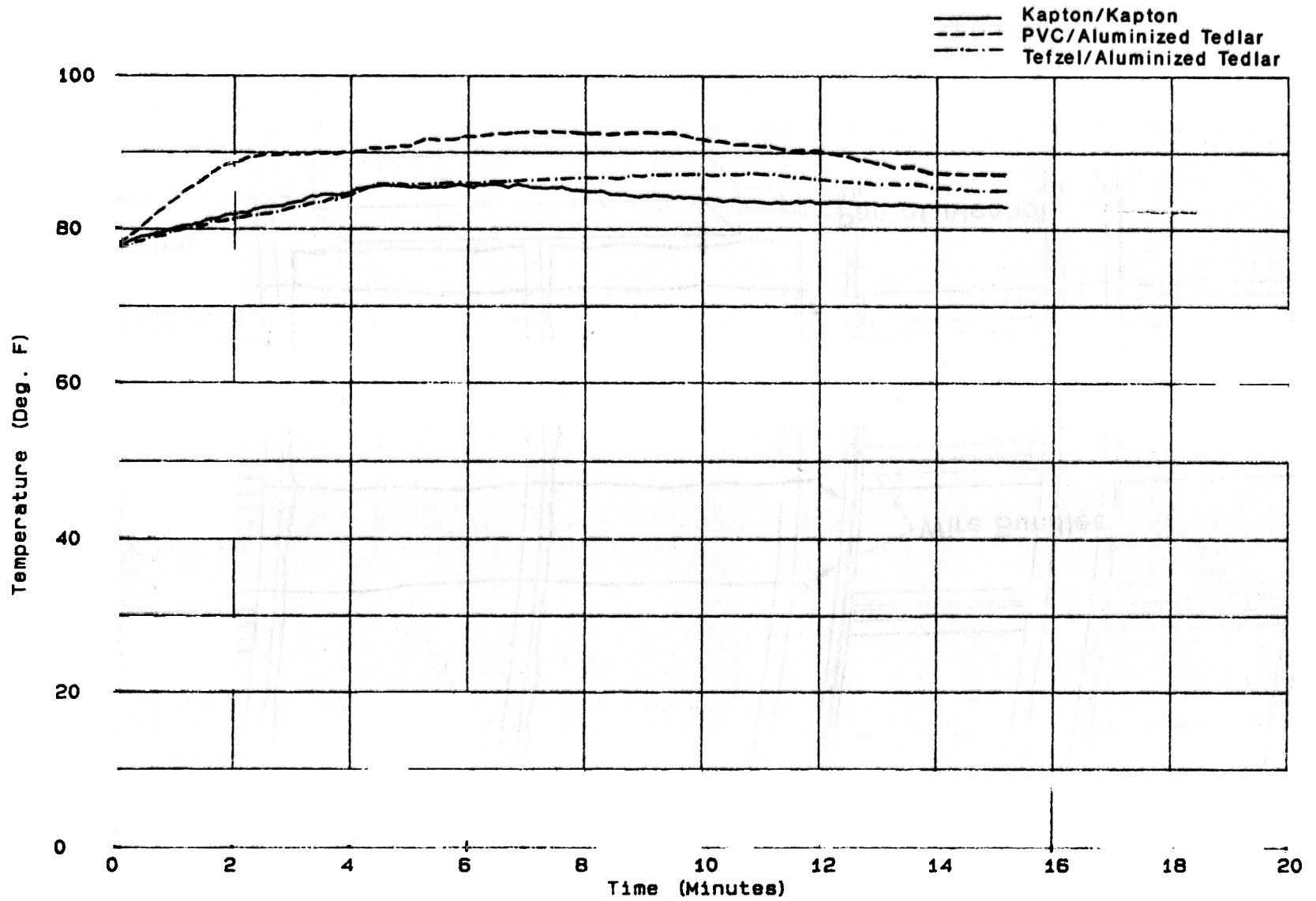

FIGURE 13. ABOVE CEILING AVERAGE TEMPERATURE--TESTS 31, 32, AND 33

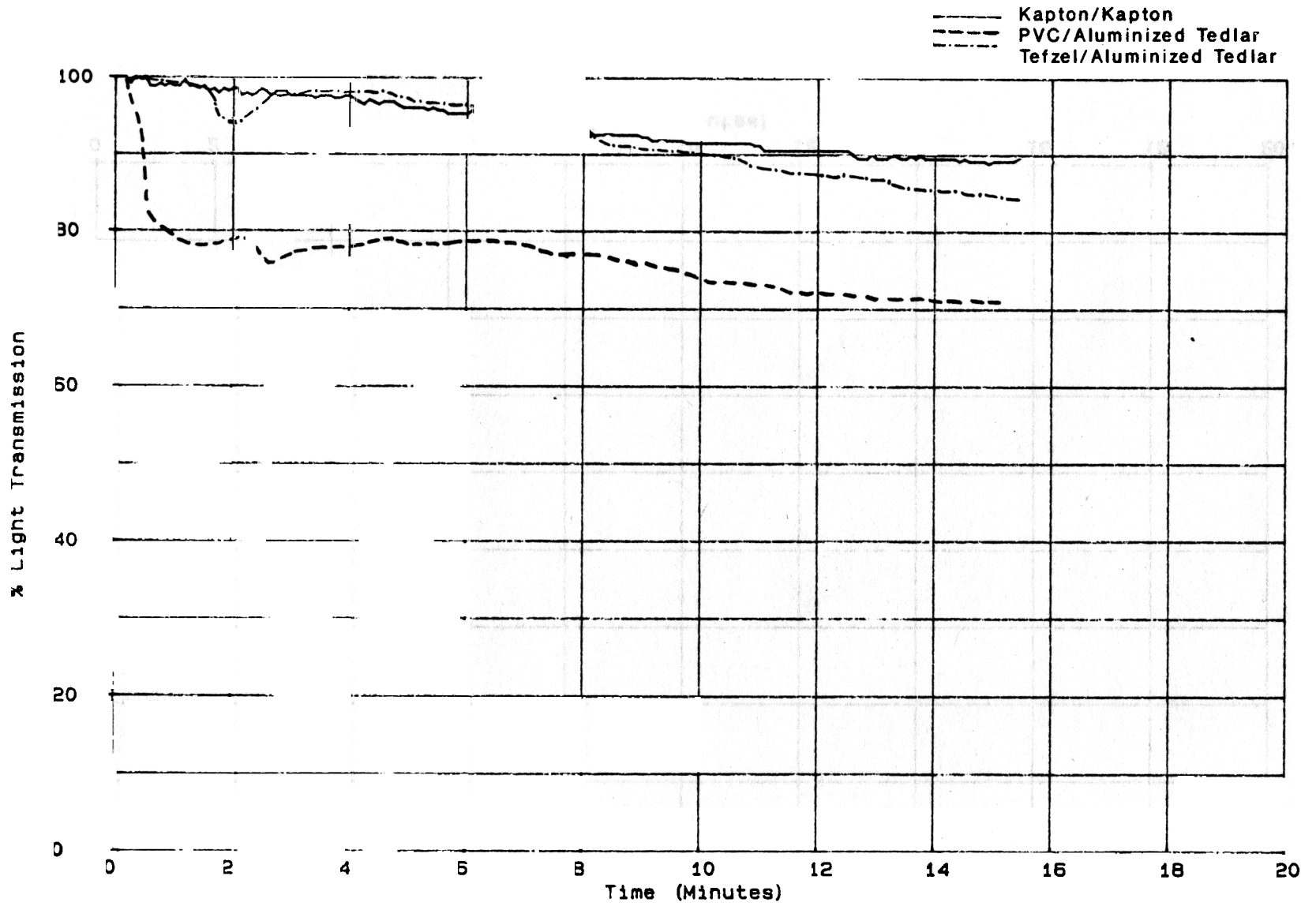

FIGURE 14. ABOVE CEILING AVERAGE SMOKE LEVEL--TESTS 31, 32, AND 33

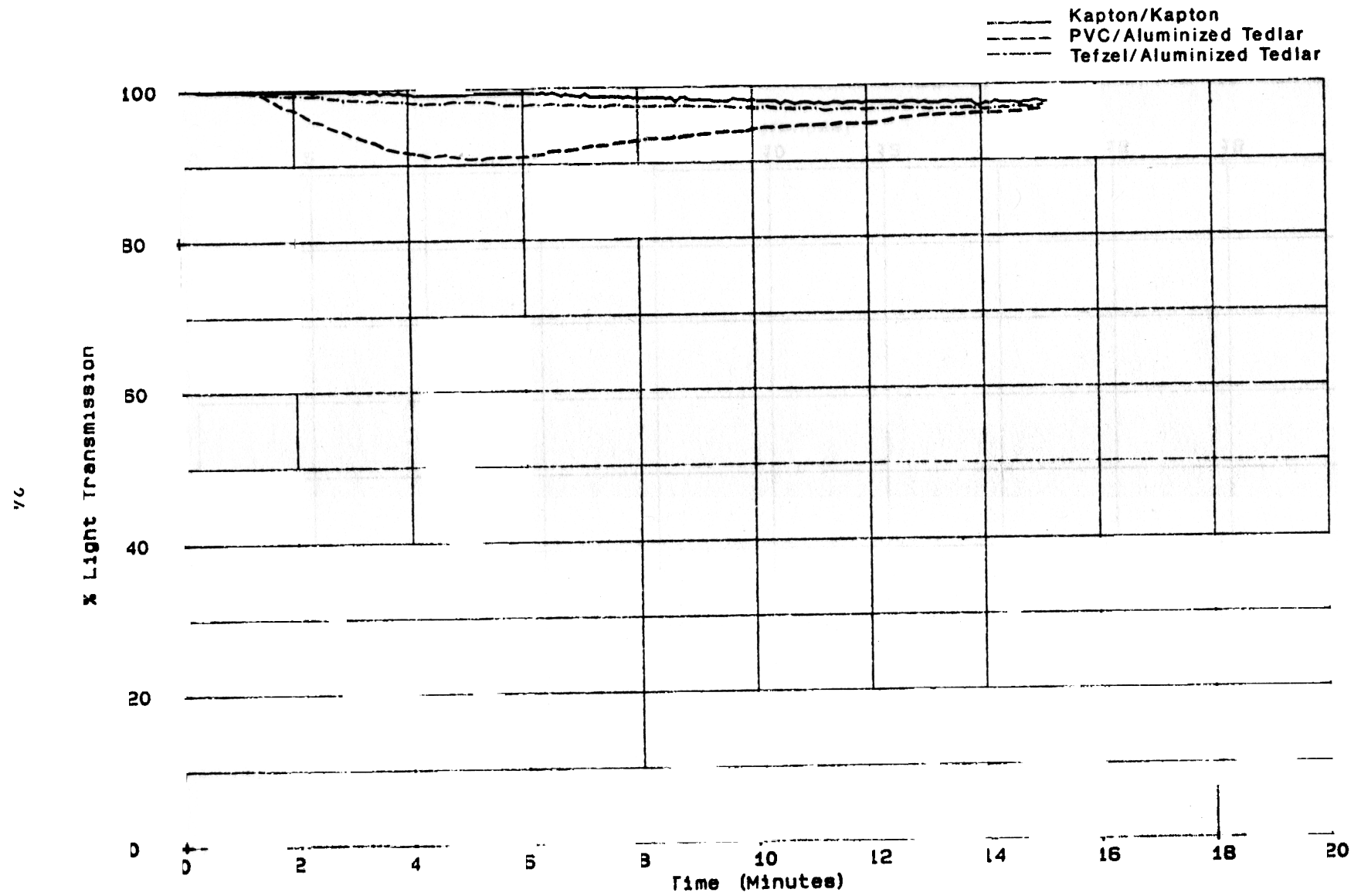

FIGURE 15. MID CABIN AVERAGE SMOKE LEVELS--TESTS 31, 32, AND 33

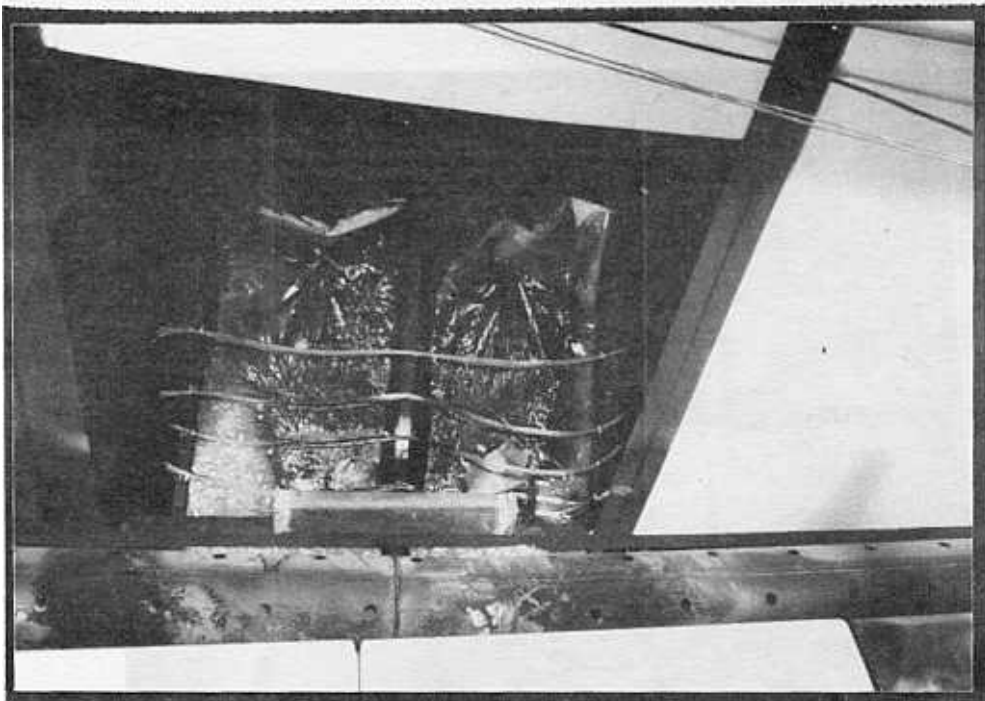
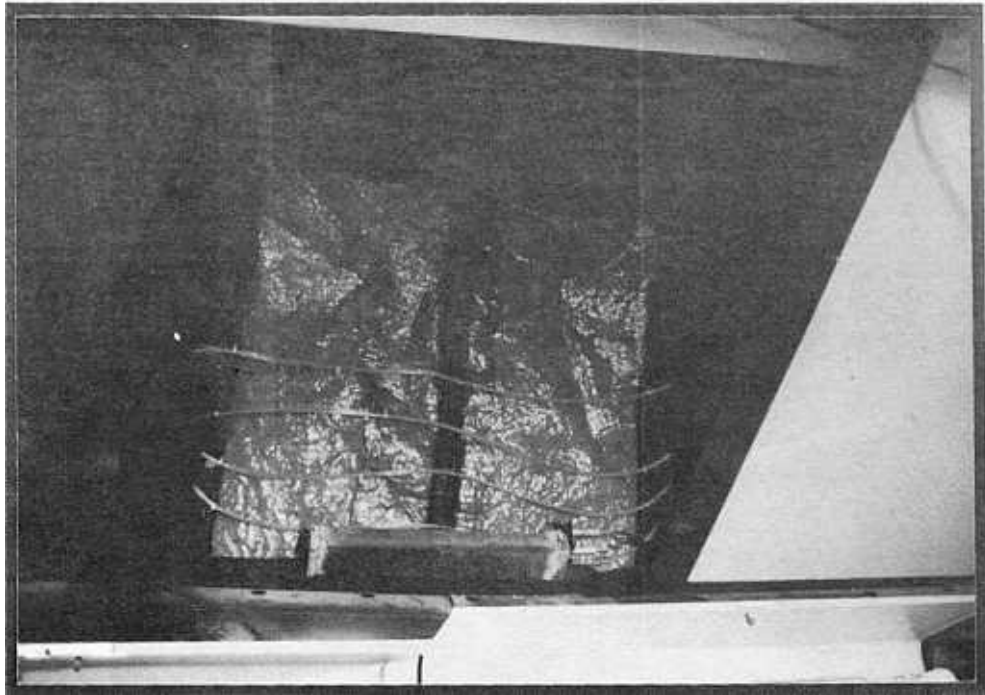

FIGURE 16. WIRE AND INSULATION BEFORE AND AFTER-TEST 31  
(Kapton Wire Insulation/Kapton Covered Batts)

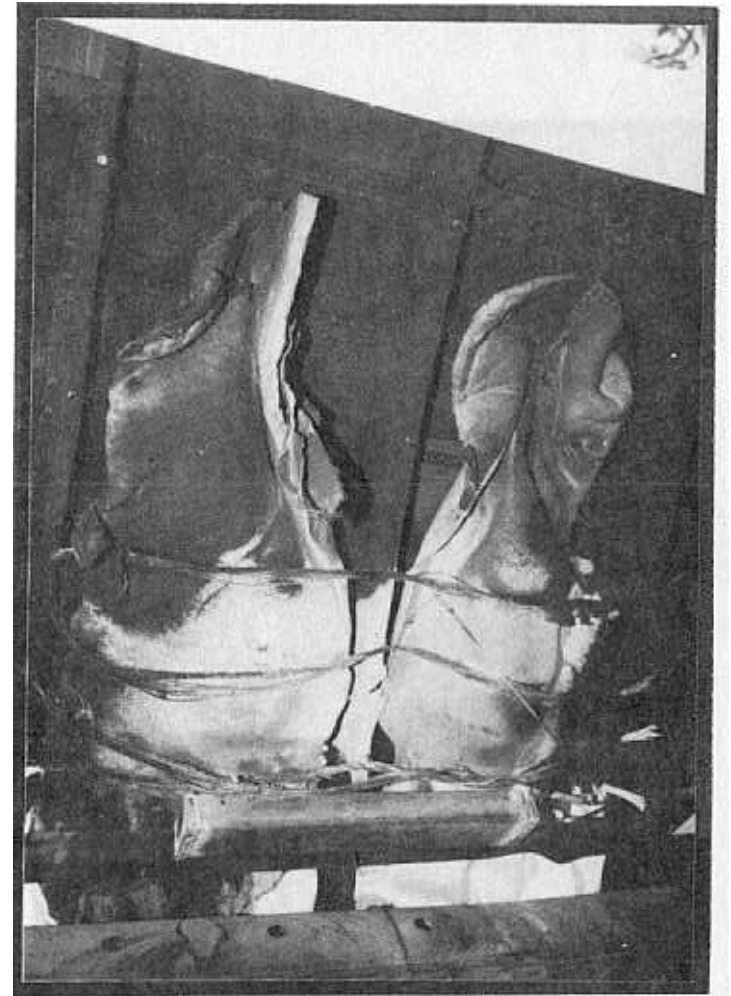
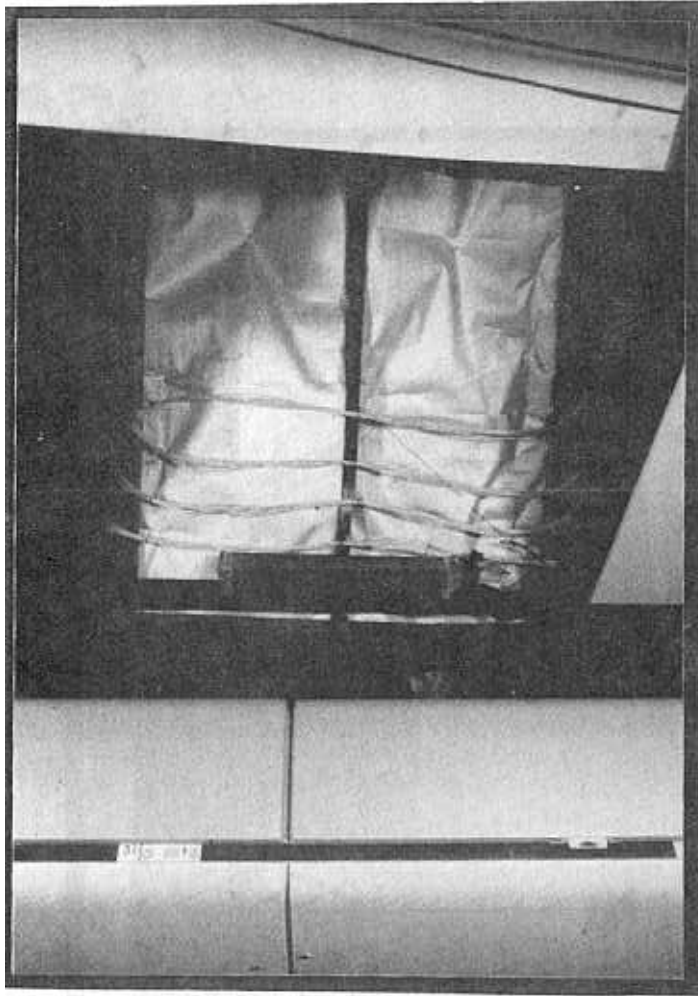

FIGURE 17. WIRE AND INSULATION BEFORE AND AFTER-TEST 32  
(PVC Wire Insulation/Aluminized Tedlar Covered Batts)



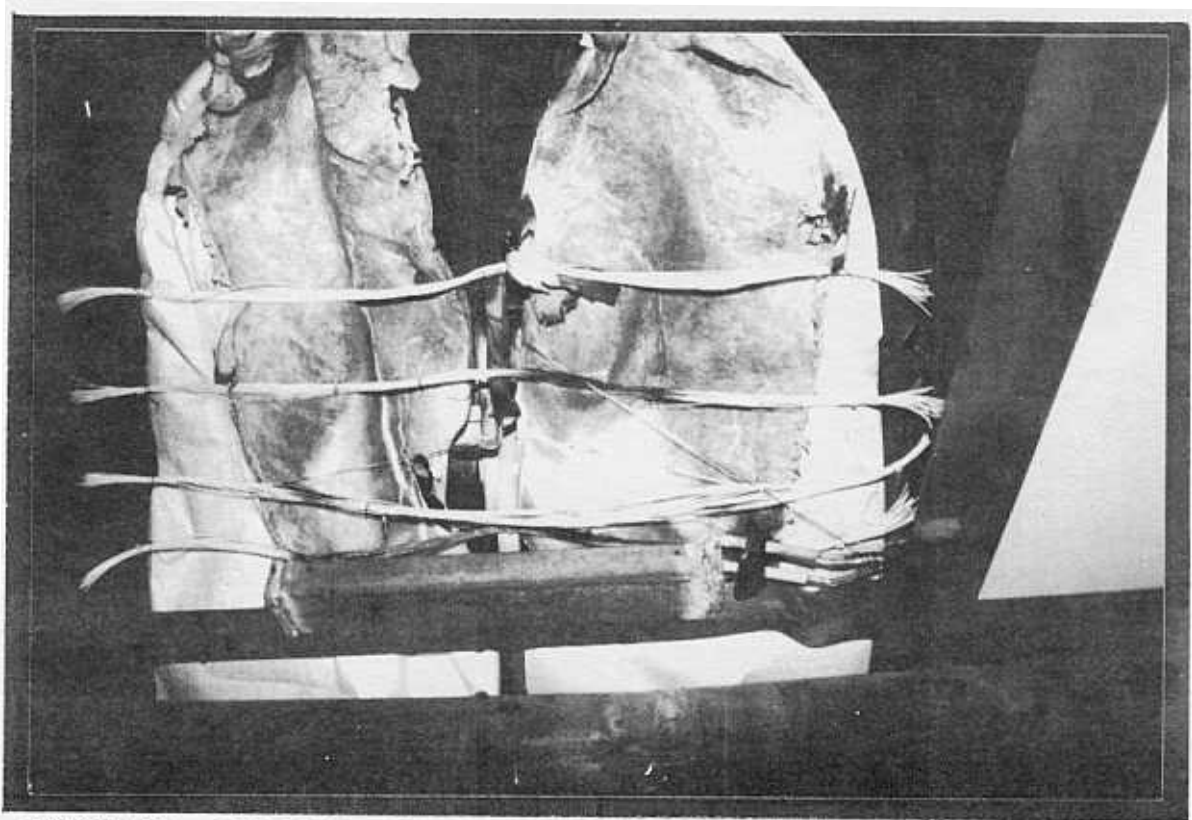
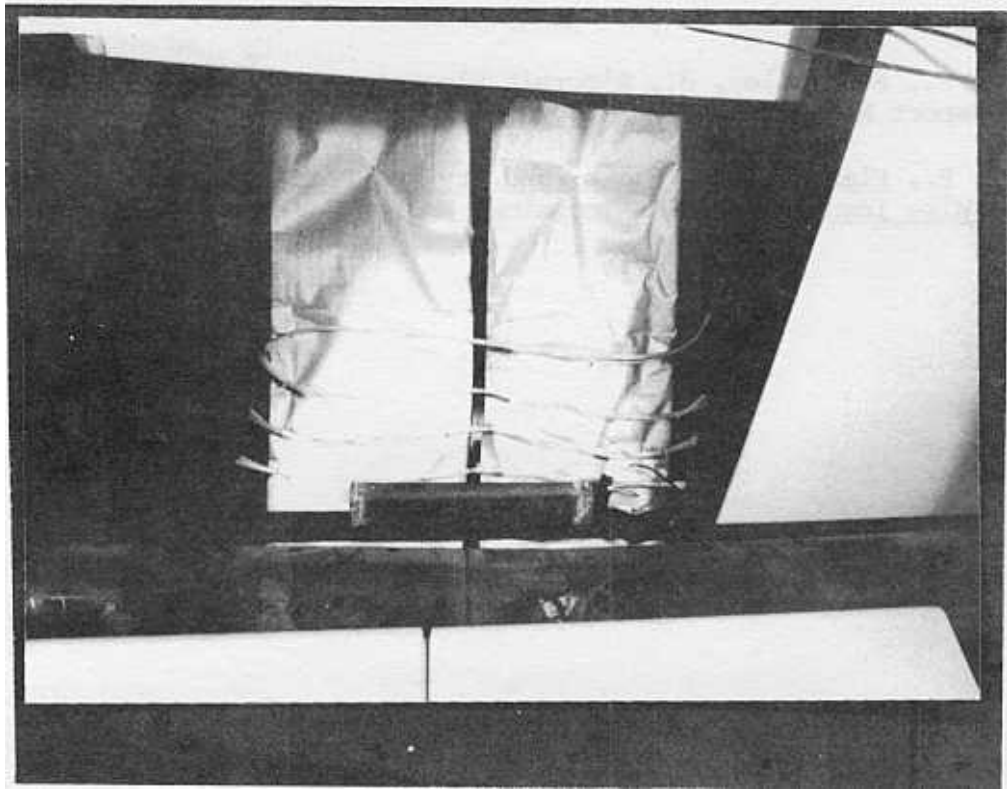

FIGURE 18. WIRE AND INSULATION BEFORE AND AFTER-TEST 33  
(Tefzel Wire Insulation/Aluminized Tedlar Covered Batts)

## REFERENCES

1. Cahill, P., and Dailey, J., Aircraft Electrical Wet-Wire Arc Tracking, FAA Technical Report No. DOT/FAA/CT-88/4, August 1988.
2. Cahill, P., Flammability, Smoke, and Dry Arc Tracking Test of Aircraft Electrical Wire Insulations, FAA Technical Report No. DOT/FAA/CT-89/21, July 1989.