

**DOT/FAA/AR-00/13**

Office of Aviation Research  
Washington, D.C. 20591

CAA Paper 99003  
Civil Aviation Authority  
London, England

# **Benefit Analysis for Aircraft 16-g Dynamic Seats**

April 2000

Final Report

This document is available to the U.S. public  
through the National Technical Information  
Service (NTIS), Springfield, Virginia 22161.



**U.S. Department of Transportation  
Federal Aviation Administration**



**Civil Aviation Authority  
London, England**

## **NOTICE**

This document is disseminated under the sponsorship of the U.S. Department of Transportation in the interest of information exchange. The United States Government assumes no liability for the contents or use thereof. The United States Government does not endorse products or manufacturers. Trade or manufacturer's names appear herein solely because they are considered essential to the objective of this report. This document does not constitute FAA certification policy. Consult your local FAA aircraft certification office as to its use.

This report is available at the Federal Aviation Administration William J. Hughes Technical Center's Full-Text Technical Reports page. [www.actlibrary.tc.faa.gov](http://www.actlibrary.tc.faa.gov) in Adobe Acrobat portable document format (PDF).

1. Report No. DOT/FAA/AR-00/13		2. Government Accession No.		3. Recipient's Catalog No.	
4. Title and Subtitle A BENEFIT ANALYSIS FOR AIRCRAFT 16-g DYNAMIC SEATS				5. Report Date April 2000	
				6. Performing Organization Code	
7. Author(s) Ray Cherry, Kevin Warren, and Aaron Chan				8. Performing Organization Report No.	
9. Performing Organization Name and Address R.G.W. Cherry & Associates Limited 20 Bull Plain Hertford Hertfordshire, SG14 1DT England				10. Work Unit No. (TRAIS)	
				11. Contract or Grant No.	
12. Sponsoring Agency Name and Address U.S. Department of Transportation Federal Aviation Administration Office of Aviation Research Washington, DC 20591				13. Type of Report and Period Covered Final Report	
				14. Sponsoring Agency Code ANM-100	
15. Supplementary Notes The FAA William J. Hughes Technical Center COTR was Richard Hill.					
16. Abstract  The objective of this study was to assess the number of serious injuries and fatalities that might have been avoided by the use of 16-g dynamic seats during the period of 1984 to 1998 for survivable accidents involving transport category aircraft operating under 14 CFR Part 121.  Twenty-five impact-related accidents involving aircraft operating to 14 CFR Part 121, or equivalent, were identified during the period from 1984 to 1998 that may have had seat-related fatal or serious injuries. Each of these accidents was analyzed in detail and a mathematical technique was used to model each accident scenario. Monte Carlo simulations were used to assess a high, median, and low value for the total achievable benefits over the period 1984 to 1998 to U.S. registered aircraft operating under 14 CFR Part 121.  Two methodologies were used. The first was based on worldwide accident data for aircraft operating under 14 CFR Part 121 or equivalent. This analysis results in the following prediction of benefit:  <ul style="list-style-type: none"> <li>• Reduction in Fatalities = 51 with a 95 percentile range from 33 to 68</li> <li>• Reduction in Serious Injuries = 54 with a 95 percentile range from 28 to 79</li> </ul> The second analysis was carried out on the accident data pertaining to U.S. aircraft operating under 14 CFR Part 121 only. The analysis of this smaller data set has resulted in the following prediction of lives to be saved:  <ul style="list-style-type: none"> <li>• Reduction in Fatalities = 23 with a 95 percentile range from 12 to 40</li> <li>• Reduction in Serious Injuries = 18 with a 95 percentile range from -1 to 32</li> </ul>					
17. Key Words Seats, 16-g seats, Crashworthiness, Cabin safety, Benefit analysis			18. Distribution Statement This document is available to the public through the National Technical Information Service (NTIS) Springfield, Virginia 22161.		
19. Security Classif. (of this report) Unclassified		20. Security Classif. (of this page) Unclassified		21. No. of Pages 241	22. Price

## TABLE OF CONTENTS

	Page
EXECUTIVE SUMMARY	v
1. INTRODUCTION	1
2. OBJECTIVES	1
3. SELECTION OF ACCIDENTS	1
4. METHOD	4
4.1 Accident Scenarios	4
4.2 Survivability Chains	4
4.3 Statistical Modelling	7
5. ANALYSIS AND RESULTS	8
5.1 Assumptions	8
5.2 Results	8
5.2.1 Assessed Benefit From Accidents Studied (14 CFR Part 121 or Equivalent)	8
5.2.2 Assessment of Benefit for the World Fleet	9
5.2.3 Benefit to U.S. 14 CFR Part 121 Aircraft	10
6. DISCUSSION	12
6.1 Accuracy of Predictions	12
6.1.1 Assumptions	12
6.1.2 Sample Size	12
6.2 Factors Influencing the Prediction	13
6.2.1 Impact and Fire Intensity	13
6.2.2 Impact Intensity	13
6.2.3 Significance of Floor Distortion	14
6.2.4 Accident Database	14
6.3 Prediction for U.S. 14 CFR Part 121 Aircraft	14
6.3.1 Benefit Based on the Assessment for the World Fleet	15
6.3.2 Benefit Based on U.S. 14 CFR Part 121 Accidents Studied	15
7. CONCLUSIONS	15
8. REFERENCES	17

9.	<b>DEFINITIONS</b>	18
	Appendix A—Accident Details and Assessment	
	Appendix B—Statistical Modelling	

## LIST OF FIGURES

Figure		Page
1	Example of Survivability Chain for an Accident Scenario	5
2	Example of Survivability Chain Showing Possible Improvements in Impact-Related Survivability Factor	5
3	Example of Survivability Chain Showing the Overall Improvements in Survivability	6
4	Potential Lives Saving With 16-g Seats	13

## LIST OF TABLES

Table		Page
1	List of Accidents Identified as Having Potential for Benefit From 16-g Seats	2
2	List of Accidents Identified as Having Potential for Benefit From 16-g Seats Showing the Number of Fatal and Serious Injuries	3
3	Summary of Assessed Reduction in Number of Fatalities and Serious Injuries for the 25 Accidents Analyzed Operating Under 14 CFR Part 121 or Equivalent	8
4	Assessed Median Benefit for the 25 Accidents Analyzed	9
5	Summary of Assessed Reduction in Number of Fatalities and Serious Injuries for the World Fleet Over the Period 1984 to 1998 Inclusive	10
6	Summary of Assessed Reduction in Number of Fatalities and Serious Injuries for U.S. 14 CFR Part 121 N-Registered Aircraft Using Data From the World Fleet	11
7	Summary of Assessed Reduction in Number of Fatalities and Serious Injuries for U.S. 14 CFR Part 121 N- Registered Aircraft Based Solely on the Accidents Analyzed	11
8	Summary of Assessed Reduction in Number of Fatalities and Serious Injuries for U.S. 14 CFR Part 121 N- Registered Aircraft Over the Period 1984 to 1998 Inclusive.	12

## EXECUTIVE SUMMARY

The objective of this study was to assess the number of serious injuries and fatalities that might have been avoided from the use of 16-g dynamic seats during the period of 1984 to 1998 for survivable accidents involving transport category aircraft operating under 14 CFR Part 121.

The International Cabin Safety Research Technical Group's Survivable Accidents Database was used to identify relevant accidents and provide detailed information.

The analytical methods employed are intended to provide as accurate an assessment as is possible with the available data, using the mathematical tools currently in existence. However, there will still remain an element of uncertainty associated with assessments of this kind, and this should be borne in mind when making decisions concerning aircraft safety that are predicated on the results of this analysis. The available data on which the assessment is based limit the accuracy of the predictions.

Twenty-five impact related accidents involving aircraft operating to 14 CFR Part 121, or equivalent, were identified during the period from 1984 to 1998 that may have had seat related fatal or serious injuries. Each of these accidents was analyzed in detail and a mathematical technique was used to model each accident scenario. Monte Carlo simulations were used to assess a high, median, and low value for the total achievable benefits over the period 1984 to 1998 to U.S. registered aircraft operating under 14 CFR Part 121.

Two methodologies were used. The first was based on worldwide accident data for aircraft operating under 14 CFR Part 121 or equivalent. This analysis results in the following prediction of benefit:

- **Reduction in Fatalities = 51** with a 95 percentile range from 33 to 68
- **Reduction in Serious Injuries = 54** with a 95 percentile range from 28 to 79

The second analysis was carried out on the accident data pertaining to U.S. aircraft operating under 14 CFR Part 121 only. The analysis of this smaller data set has resulted in the following prediction of lives to be saved:

- **Reduction in Fatalities = 23** with a 95 percentile range from 12 to 40
- **Reduction in Serious Injuries = 18** with a 95 percentile range from -1 to 32

A negative value for the reduction in serious injuries is associated with situations where the number of fatal injuries reduced to serious injuries is higher than the number of serious injuries reduced to minor or no injuries. The net outcome is an increase in serious injuries.

Account has been taken of the reduction in fire threat afforded to the impact survivors by the improved fireworthiness of cabin interiors compliant with the standards defined in 14 CFR Part 25 at amendment 72.

The fire threat is often severe in accidents where 16-g seats are likely to reduce the number of impact injuries and fatalities. This is a significant factor in terms of the ultimate benefit attained even when the recent improvements in the fireworthiness of aircraft cabins is taken into account.

Due to the extensive disruption to the floor during the impact sequence, a number of accidents analyzed would not have any potential for lives being saved with the introduction of 16-g seats.

The current database has very few accidents with 100% fatalities. It is unlikely that there are many lives to be saved from the introduction of 16-g seats in accidents of this severity. However, it is feasible that the benefit assessment might increase slightly if accidents of this type were studied.

## **1. INTRODUCTION**

This report has been prepared on behalf of the U.S. Federal Aviation Administration (FAA). It contains the method and results of a benefit analysis on 16-g dynamic seats intended to improve crashworthiness for aircraft type certificated with 30 or more passenger seats operating to 14 CFR Part 121. A number of past impact-related accidents have been identified which are considered to have involved injuries to occupants that may have been ameliorated had fully compliant 16-g dynamic seats been fitted.

For each of the accidents identified, the assessed benefit in terms of the potential reduction in number of fatalities and injuries was derived assuming improvements resulting from the use of 16-g dynamic seats. The assessment was carried out such that it reflects the benefit likely to accrue to aircraft compliant with the latest standard of cabin fireworthiness as prescribed in 14 CFR Part 25 at amendment 72.

The methodology used is aimed at providing an indication as to the order of benefit likely to be achieved. Certain assumptions have been made in the analysis of data. The more significant of these are described in paragraph 5.1.

Any analysis of this kind must involve a degree of subjective judgement and relies on the accuracy of the data available. The analytical methods employed are intended to provide as accurate an assessment as is possible with the available data, using the mathematical tools currently in existence. However, there will still remain an element of uncertainty associated with assessments of this kind, and this should be borne in mind when making decisions concerning aircraft safety that are predicated on the results of this analysis.

Section 9 of this report contains the definition of terms used in this study.

## **2. OBJECTIVES**

The objective of this study was to assess the number of serious injuries and fatalities that might be avoided by the use of 16-g dynamic seats based on a study of past accidents occurring over the period 1984 to 1998.

## **3. SELECTION OF ACCIDENTS**

Accidents involving fatalities or serious injuries were selected from the Survivable Accidents Database of the International Cabin Safety Research Technical Group. This database contains details of accidents to the world fleet of passenger carrying aircraft.

The current standard of the database contains information on 393 impact-related accidents over the period 1984 to 1998 inclusive. Of these, 60 accidents have detailed textual information and 43 involve injury, fatal or serious, to occupants. A preliminary study of these accidents showed that five were not in any way associated with occupant injuries



that could have been ameliorated by seat design. Of the remaining 38, 25 involved 14 CFR Part 121 or equivalent aircraft. These accidents are shown in table 1.

TABLE 1. LIST OF ACCIDENTS IDENTIFIED AS HAVING POTENTIAL FOR BENEFIT FROM 16-g SEATS

Date	Location	Aircraft	TCA Operation
20-Dec-95	Buga, Nr. Cali, Colombia	B757-223	Part 121
02-Jul-94	Charlotte Airport, Charlotte, North Carolina	DC9-31	Part 121
26-Apr-94	Nagoya/Komaki Airport, Nagoya, Japan	A300B4-622R	{Part 121}
21-Mar-94	Vigo Airport, Spain	DC9-32	{Part 121}
14-Sep-93	Warsaw, Poland	A320-211	{Part 121}
06-Apr-93	Nr. Shemya, Alaska, U.S.A.	MD11	{Part 121}
21-Dec-92	Faro, Portugal	DC10-30CF	{Part 121}
22-Mar-92	La Guardia, New York, U.S.A.	F28-4000 a	Part 121
20-Jan-92	Nr Strasbourg, France	A320-100	{Part 121}
01-Feb-91	Los Angeles, California, U.S.A.	B737-300	Part 121
03-Dec-90	Romulus, Detroit, U.S.A.	DC9-14	Part 121
14-Feb-90	Bangalore, India	A320-231	{Part 121}
25-Jan-90	Cove Neck, Long Island, New York, U.S.A.	B707-321B	{Part 121}
20-Sep-89	La Guardia, New York, U.S.A.	B737-400	Part 121
19-Jul-89	Sioux City, Iowa, U.S.A.	DC10-10	Part 121
10-Mar-89	Dryden, Ontario, Canada	F28 Mk1000	{Part 121}
08-Jan-89	Kegworth, East Midlands Airport, U.K.	B737-400	{Part 121}
31-Aug-88	Hong Kong	TRIDENT 2E	{Part 121}
31-Aug-88	Dallas Fort Worth, Texas, U.S.A.	B727-232	Part 121
26-Jun-88	Habsheim	A320-100	{Part 121}
15-Apr-88	Seattle-Tacoma Intl. Airport, Seattle, Washington, U.S.A.	DHC8-102	Part 121
15-Nov-87	Denver, Colorado, U.S.A.	DC9-14	Part 121
16-Aug-87	Detroit, Michigan, USA	DC9-82	Part 121
02-Aug-85	Dallas Fort Worth, Texas, U.S.A.	L1011-385-1	Part 121
21-Jan-85	Reno, Nevada, U.S.A.	L188C	Part 121

Note: {Part 121} means non-US registered aircraft operating to the equivalent of 14 CFR Part 121.

The list shown in table 2 shows the total number of fatalities and serious injuries to occupants resulting from the accidents selected for study.

TABLE 2. LIST OF ACCIDENTS IDENTIFIED AS HAVING POTENTIAL FOR BENEFIT FROM 16-g SEATS SHOWING THE NUMBER OF FATAL AND SERIOUS INJURIES

Date	Location	Aircraft	Total No. of Fatalities	Total No. of Serious Injuries
20-Dec-95	Buga	B757	159	4
02-Jul-94	Charlotte	DC9-31	37	16
26-Apr-94	Nagoya	A300B4	264	7
21-Mar-94	Vigo	DC9-32	0	2
14-Sep-93	Warsaw	A320	2	47
06-Apr-93	Shemya	MD11	2	60
21-Dec-92	Faro	DC10	56	Unknown
22-Mar-92	La Guardia	F28-4000	27	9
20-Jan-92	Strasbourg	A320	87	5
01-Feb-91	Los Angeles	B737	22	13
03-Dec-90	Romulus	DC9-14	8	10
14-Feb-90	Bangalore	A320	92	22
25-Jan-90	Cove Neck	B707	73	81
20-Sep-89	La Guardia	B737	2	3
19-Jul-89	Sioux City	DC10-10	111	47
10-Mar-89	Dryden	F28	24	18
08-Jan-89	Kegworth	B737	47	74
31-Aug-88	Hong Kong	TRIDENT	7	4
31-Aug-88	Dallas	B727-232	14	26
26-Jun-88	Habsheim	A320-100	3	30
15-Apr-88	Seattle	DHC8	0	4
15-Nov-87	Denver	DC9-14	28	28
16-Aug-87	Detroit	DC9-82	154	1
02-Aug-85	Dallas	L1011	134	15
21-Jan-85	Reno	L188C	70	1

These accidents were then subjected to the benefit analysis methodology described in section 4.

## 4. METHOD

### 4.1 ACCIDENT SCENARIOS

The severity of hazard in an accident can vary markedly throughout the aircraft. Experience has shown that considering occupant injuries on a whole aircraft basis can be misleading when assessing the effects of survivability factors. It is therefore necessary to divide the aircraft into scenarios.

A scenario is defined as:

*“That volume of the aircraft in which the occupants are subjected to a similar level of threat.”*

A similar level of threat need not necessarily result in the same level of injury to occupants. The extent of injury sustained can vary with numerous factors including age, sex, adoption of the brace position, etc. Furthermore, the threat to occupants can vary over relatively small distances. For example, a passenger may receive fatal injuries because of being impacted by flying debris, and a person in an adjacent seat may survive uninjured. Dividing accidents into scenarios provides a more meaningful basis on which to analyse accidents than considering the whole aircraft due to the marked variation in survival potential with occupant location.

The flight deck and flight attendant areas are generally considered as separate scenarios. The flight crewmembers usually have full harness restraints, and sliding cockpit windows in the area provide a nearby method of egress. The flight attendant areas are also normally considered as a separate scenario from the passenger cabin due to the significant differences in seating, restraint systems, and exit availability.

For these reasons, where sufficient data are available the analytical work is based on assessments carried out for each accident scenario.

### 4.2 SURVIVABILITY CHAINS

A mathematical model, known as a Survivability Chain (see figure 1) has been developed, by RGW Cherry & Associates Ltd. It enables an assessment to be made of the overall effect on survivability, from improvements made to survivability factors, taking into account injuries that may be sustained by occupants. In this case, the survivability factor is 16-g dynamic seats.

Where sufficient data are available, each accident is divided into scenarios and a Survivability Chain constructed.

The following is an example of the model and the effects of improvement in injuries and fatalities resulting from changes to survivability factors.

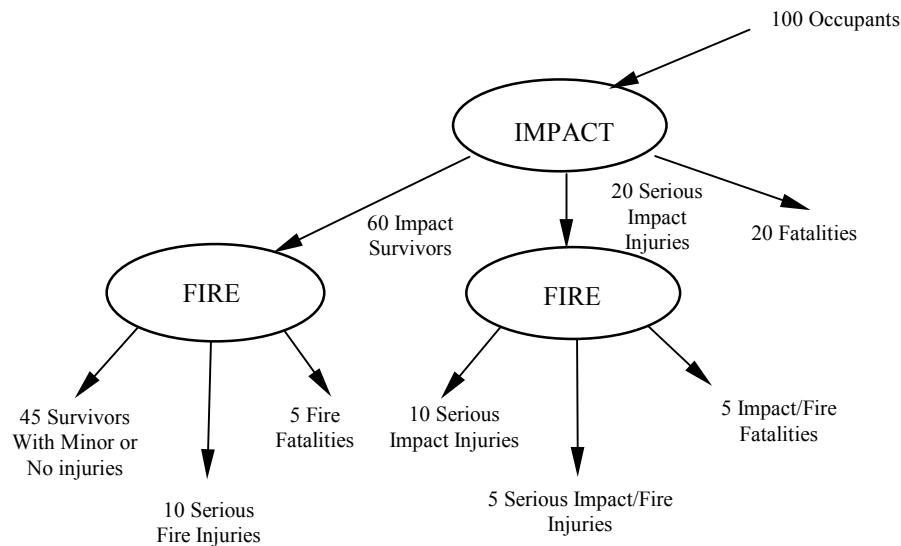

FIGURE 1. EXAMPLE OF SURVIVABILITY CHAIN FOR AN ACCIDENT SCENARIO

In this example, of the 100 occupants in the scenario there are:

- 45 uninjured survivors.
- 25 serious injuries, 10 as a result of the impact, 10 as a result of the fire, and 5 seriously injured as a result of the impact and fire.
- 30 fatalities, 20 as a result of the impact, and 10 as a result of the fire (5 of whom sustained nonfatal injuries from the impact).

If improvements are made to an impact-related survivability factor, such that there are only 12 fatalities and 16 seriously injured of the 100 occupants, the Survivability Chain then becomes:

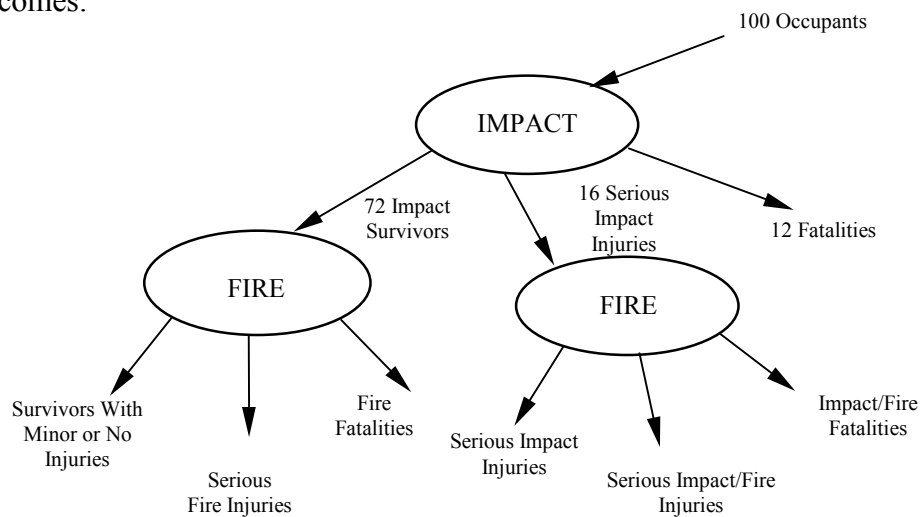

FIGURE 2. EXAMPLE OF SURVIVABILITY CHAIN SHOWING POSSIBLE IMPROVEMENTS IN IMPACT-RELATED SURVIVABILITY FACTOR

It is known from the accident that  $5/60^{\text{th}}$  of those that survive the impact uninjured and  $5/20^{\text{th}}$  of those that sustain injuries from the impact subsequently died because of the fire. Furthermore,  $10/60^{\text{th}}$  of those that survive the impact are seriously injured due to fire and  $5/20^{\text{th}}$  of those that sustain serious injuries from the impact also sustain serious injuries because of the fire. It is assumed that these ratios are constant for this particular scenario.

On this basis an assessment of the numbers of fatalities and injuries may be made as follows:

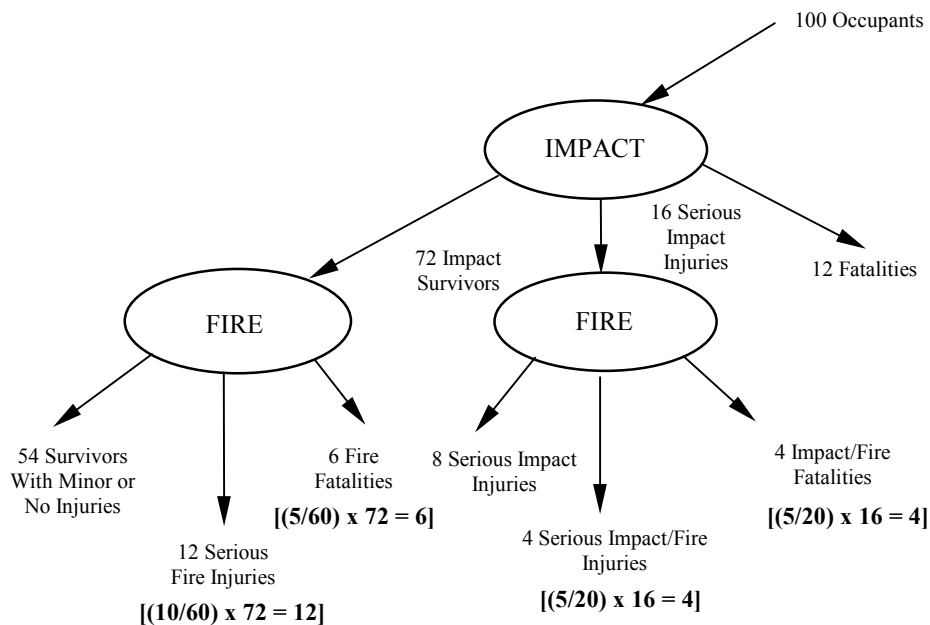

FIGURE 3. EXAMPLE OF SURVIVABILITY CHAIN SHOWING THE OVERALL IMPROVEMENTS IN SURVIVABILITY

Hence, the improvement to the impact related survivability factor results in:

- 54 survivors
- 24 serious injuries, 8 as a result of the impact, 12 as a result of the fire, and 4 seriously injured as a result of the impact and fire
- 22 fatalities, 12 because of the impact and 10 because of the fire (4 of whom sustained nonfatal injuries from the impact).

It should be noted that the survivability factor improvement resulted in a reduction in impact fatalities of 8 and impact injuries of 4. However, the overall situation is as follows:

	<u>Survivors</u>	<u>Serious Injuries</u>	<u>Fatalities</u>
Prior to survivability factor improvement:	45	25	30
Post survivability factor improvement:	54	24	22

### 4.3 STATISTICAL MODELLING

A software package was developed to use the Survivability Chain model in a mathematical representation of an accident using Monte Carlo simulations. This enables an assessment to be made of the change in numbers of survivors, injuries, and fatalities resulting from predictions of the range of improvements that may be possible from changes to a survivability factor. This simulation process is described in detail in appendix B.

For each scenario, a numerical assessment is made of the impact on number of fatalities and injuries because of changes resulting from the introduction of 16-g seats. The assessment results in a prediction of the highest, mean, and lowest number of fatalities and injuries that could reasonably be expected from the change.

From the example described in section 4.2, the best (or median) assessment was that improvements to the survivability factor relating to impact deaths resulted in an improvement in the number of fatalities from 20 to 12. Similarly, the impact injuries reduced from 20 to 16. When making this determination, an assessment would also be made of the maximum and minimum number of fatalities and injuries that are likely to result from the introduction of 16-g seats.

It is then assumed that there can be 100% confidence that the fatalities and injuries will lie in the range from the maximum to the minimum. The 50-percentile point of the confidence level distribution corresponds to the best or median assessment.

The accidents analyzed involved aircraft with varying standards of fireworthiness. To determine the benefit likely to be accrued by aircraft compliant with today's standards, an allowance was made for a reduction in fire fatalities and injuries that might result from the improved fire characteristics of cabin materials compliant with the standards introduced by 14 CFR Part 25 amendments 61 and 72.

From this a re-evaluation of the resultant number of survivors, serious injuries, and fatalities may be made using the Survivability Chain generated for the accident scenario. This is then compared with the actual outcome of the accident scenario and the improvement in the number of fatalities and serious injuries derived. The software

makes 9999 iterations of random selections over the range 0 to 100% to generate a distribution of the degree of improvement. From this distribution, the 2½-, 50-, and 97½-percentile values are selected to represent the best assessment of the improvement and its likely range.

Whilst it is recognised that the models are not perfect representations of an accident nor are the statistical assessments totally accurate, they will provide a better assessment of the likely effects of improvements to survivability factors than would otherwise be derived from a simple estimate of the resultant change in number of survivors.

## 5. ANALYSIS AND RESULTS

### 5.1 ASSUMPTIONS

The following assumptions were made:

- a. The 16-g seats are designed to survive a deceleration force of 16 g's in the longitudinal direction and limit the floor track loads to 9 g's.
- b. If seat standards were not specifically stated in the accident report, they were normally considered not to be 16-g seats.
- c. No disbenefit from the introduction of 16-g seats has been considered. For example, 16-g seats might reduce the evacuation capability of occupants due to seat backs not breaking over.
- d. Where data were insufficient to make a more accurate prediction, the median assessment was taken as being mid-way between the maximum number of lives to be saved from the introduction of 16-g seats and the assessed minimum.

### 5.2 RESULTS

#### 5.2.1 ASSESSED BENEFIT FROM ACCIDENTS STUDIED (14 CFR PART 121 OR EQUIVALENT)

Table 3 presents the high, median (best estimate), and low predictions of the effect of 16-g seats on the total number of fatalities and injuries. The predictions are based on 9999 iterations across the 25 accidents identified for analysis; table 4 lists the assessed median benefit for the 25 accidents analyzed.

TABLE 3. SUMMARY OF ASSESSED REDUCTION IN NUMBER OF FATALITIES AND SERIOUS INJURIES FOR THE 25 ACCIDENTS ANALYZED OPERATING UNDER 14 CFR PART 121 OR EQUIVALENT

	LOW	MEDIAN	HIGH
REDUCTION IN FATALITIES	41	62	83
REDUCTION IN SERIOUS INJURIES	34	66	97

Note: Assessed benefit rounded to whole number of lives.

TABLE 4. ASSESSED MEDIAN BENEFIT FOR THE 25 ACCIDENTS ANALYZED

Date	Location	Aircraft	TCA Operation	Total No. of Fatalities	Total No. of Serious Injuries	Benefit	
						Lives Saved	Injuries Saved
20-Dec-95	Buga, Cali	B757	Part 121	159	4	0	0
02-Jul-94	Charlotte	DC9-31	Part 121	37	16	3	0
26-Apr-94	Nagoya	A300B4	{Part 121}	264	7	0	0
21-Mar-94	Vigo	DC9-32	{Part 121}	0	2	0	0
14-Sep-93	Warsaw	A320	{Part 121}	2	47	0	4
06-Apr-93	Shemya	MD11	{Part 121}	2	60	0	25
21-Dec-92	Faro	DC10	{Part 121}	56	U/K	3	6
22-Mar-92	La Guardia	F28-4000	Part 121	27	9	4	5
20-Jan-92	Strasbourg	A320	{Part 121}	87	5	7	-5
01-Feb-91	Los Angeles	B737	Part 121	22	13	0	0
03-Dec-90	Romulus	DC9-14	Part 121	8	10	0	0
14-Feb-90	Bangalore	A320	{Part 121}	92	22	9	-5
25-Jan-90	Cove Neck	B707	{Part 121}	73	81	23	21
20-Sep-89	La Guardia	B737	Part 121	2	3	0	0
19-Jul-89	Sioux City	DC10-10	Part 121	111	47	3	1
10-Mar-89	Dryden	F28	{Part 121}	24	18	0	5
08-Jan-89	Kegworth	B737	{Part 121}	47	74	5	0
31-Aug-88	Hong Kong	TRIDENT	{Part 121}	7	4	0	0
31-Aug-88	Dallas	B727-232	Part 121	14	26	0	0
26-Jun-88	Habsheim	A320-100	{Part 121}	3	30	0	0
15-Apr-88	Seattle	DHC8	Part 121	0	4	0	2
15-Nov-87	Denver.	DC9-14	Part 121	28	28	4	5
16-Aug-87	Detroit	DC9-82	Part 121	154	1	0	0
02-Aug-85	Dallas	L1011	Part 121	134	15	0	2
21-Jan-85	Reno	L188C	Part 121	70	1	1	0

Note: {Part 121} means non-US registered aircraft operating to the equivalent of 14 CFR Part 121. A negative value for serious injuries is associated with situations where the number of fatal injuries reduced to serious injuries is higher than the number of serious injuries reduced to minor or no injuries. The net outcome is an increase in serious injuries.

### 5.2.2 ASSESSMENT OF BENEFIT FOR THE WORLD FLEET

Twenty-five accidents were identified as matching the selection criteria in section 3 and were used for the benefit analysis.



It is considered likely that there are other accidents where seat-related injuries occurred, but because there are little or no data available, they cannot be analyzed. If other accidents have occurred then the derived benefit would increase proportionately.

It is assumed that the accidents available for analysis are representative of all impact-related accidents. In order to assess the likely benefit for the world fleet it is necessary to know the proportion that the accidents analyzed represent of all those that could have involved seat-related injuries. Ideally, all impact-related accidents involving injury would be used to derive this proportion. However since it is possible that a significant number of accidents involving only serious injury have not been widely reported, and hence do not appear in the database, the assessment was based on impact-related fatal accidents only.

There are 226 impact-related accidents with fatalities in the Accident Database for the period of 1984 to 1998. Of these, 145 were considered Part 121 or equivalent and 27 of them have detailed textual information.

If the accidents not having available accident data have a similar benefit potential to those that do, then it is likely that the levels actually realised will be 145/27 or approximately 5.37 times those contained in table 3. (It should be noted that the 25 accidents analyzed in this report involved seat-related injuries, whilst the 27 accidents are all impact-related fatal accidents having textual information with or without seat-related injuries.)

Therefore, applying this factor to the benefit derived from the accidents studied results in the assessed median lives saved as shown in table 5.

TABLE 5. SUMMARY OF ASSESSED REDUCTION IN NUMBER OF FATALITIES AND SERIOUS INJURIES FOR THE WORLD FLEET OVER THE PERIOD 1984 TO 1998 INCLUSIVE

	LOW	MEDIAN	HIGH
REDUCTION IN FATALITIES	220	333	446
REDUCTION IN SERIOUS INJURIES	183	354	521

Note: Assessed benefit rounded to whole number of lives.

### 5.2.3 BENEFIT TO U.S. 14 CFR PART 121 AIRCRAFT

Two methods were used to estimate the benefit of 16-g seats applicable to U.S. 14 CFR Part 121 N-registered aircraft.

The first method used the predicted reduction in fatalities and injuries assessed for the world fleet factored by the proportion of accidents occurring to U.S. Part 121 aircraft over the period 1984 to 1998.

The second method employed was to derive the benefit directly from the Part 121 N-registered aircraft analyzed.

### 5.2.3.1 Benefit Based on the Assessment for the World Fleet

Of the 145 14 CFR Part 121 or equivalent impact-related fatal accidents in the database for the world fleet, only 22 accidents (15.2%) involved U.S. Part 121 N-registered aircraft. It is assumed that the U.S. fleet and the world fleet of Part 121, or equivalent, aircraft are compatible in terms of seat related injuries. On this basis, the benefit to the U.S. fleet may be derived from the proportion of impact-related fatal accidents occurring to N-registered aircraft.

Applying a factor of 0.152 (22/145) to the benefit derived from the accidents studied in table 5 results in the assessed median lives saved as shown in table 6. Impact related fatal accidents were used to derive this proportion for the reasons given in section 5.2.2.

TABLE 6. SUMMARY OF ASSESSED REDUCTION IN NUMBER OF FATALITIES AND SERIOUS INJURIES FOR U.S. 14 CFR PART 121 N-REGISTERED AIRCRAFT USING DATA FROM THE WORLD FLEET

	LOW	MEDIAN	HIGH
REDUCTION IN FATALITIES	33	51	68
REDUCTION IN SERIOUS INJURIES	28	54	79

Note: Assessed benefit rounded to whole number of lives.

### 5.2.3.2 Benefit Based on U.S. 14 CFR Part 121 Accidents Studied

Thirteen of the U.S. 14 CFR Part 121 N-registered aircraft were been analyzed (see table 4). The Monte Carlo simulation programme was used to assess the reduction in the number of fatalities and injuries.

Table 7 presents the high, median (best estimate), and low predictions of the reduction in the total number of fatalities and injuries across the thirteen accidents that are U.S. Part 121 aircraft over the period 1984 to 1998.

TABLE 7. SUMMARY OF ASSESSED REDUCTION IN NUMBER OF FATALITIES AND SERIOUS INJURIES FOR U.S. 14 CFR PART 121 N-REGISTERED AIRCRAFT BASED SOLELY ON THE ACCIDENTS ANALYZED

	LOW	MEDIAN	HIGH
REDUCTION IN FATALITIES	8	16	27
REDUCTION IN SERIOUS INJURIES	-1	12	22

- Notes: 1. Assessed benefit rounded to whole number of lives.  
 2. A negative value for serious injuries is associated with situations where the number of fatal injuries reduced to serious injuries is higher than the number of serious injuries reduced to minor or no injuries. The net outcome is an increase in serious injuries.

There are 22 Part 121 N-registered aircraft impact-related accidents in the database of which only 15 accidents (15/22 = 68.2%) have detailed textual information.

If the accidents not having available accident data have a similar benefit potential to those that do, then it is likely that the levels actually realised will be approximately 1.47 times (1/0.682) those contained in table 7.

Applying this factor to the benefit derived from the accidents studied results in the assessed median lives saved as shown in table 8.

TABLE 8. SUMMARY OF ASSESSED REDUCTION IN NUMBER OF FATALITIES AND SERIOUS INJURIES FOR U.S. 14 CFR PART 121 N-REGISTERED AIRCRAFT OVER THE PERIOD 1984 TO 1998 INCLUSIVE

	LOW	MEDIAN	HIGH
REDUCTION IN FATALITIES	12	23	40
REDUCTION IN SERIOUS INJURIES	-1	18	32

- Notes: 1. Assessed benefit rounded to whole number of lives.  
 2. A negative value for serious injuries is associated with situations where the number of fatal injuries reduced to serious injuries is higher than the number of serious injuries reduced to minor or no injuries. The net outcome is an increase in serious injuries.

## 6. DISCUSSION

### 6.1 ACCURACY OF PREDICTIONS

The analytical methods employed are intended to provide as accurate an assessment as is possible with the available data using the mathematical tools currently in existence. However, there will still remain an element of uncertainty associated with assessments of this kind, and this should be borne in mind when making decisions concerning aircraft safety that are predicated on the results of this analysis. Any analysis of this kind must involve a degree of subjective judgement and relies on the accuracy of the data available.

#### 6.1.1 ASSUMPTIONS

The methodology used is aimed at providing an indication as to the order of benefit likely to be achieved. Certain assumptions have been made in the analysis of data and the more significant ones are described in paragraph 5.1.

#### 6.1.2 SAMPLE SIZE

There are thirteen U.S. Part 121 N-registered aircraft accidents that were analyzed in this study. However, only seven accidents were assessed to have potential benefit, in terms of reduction in the number of fatal and serious injuries, if 16-g seats were introduced.

The range of benefit indicated in the Results section of this report is representative of an error band in the assessment for the accidents that were studied. However, it does not give any indication of the likely error resulting from the analysis being based on small samples.

The benefit assessment based on the World Fleet is likely to result in a more accurate prediction since it is based on a larger sample size.

## 6.2 FACTORS INFLUENCING THE PREDICTION

### 6.2.1 IMPACT AND FIRE INTENSITY

### 6.2.2 IMPACT INTENSITY

From a previous study [1], it was suggested that the proportion of fatal and serious injuries in an accident scenario was of a form similar to that shown in figure 4. It is evident that there will not be any benefit from the introduction of 16-g seats when the impact intensity is beyond their level of resilience. Furthermore, at impact intensities below those sustainable by 9-g seats, there would be little benefit beyond that afforded by improvements to seat design associated with the enhanced Head Injury Criteria.

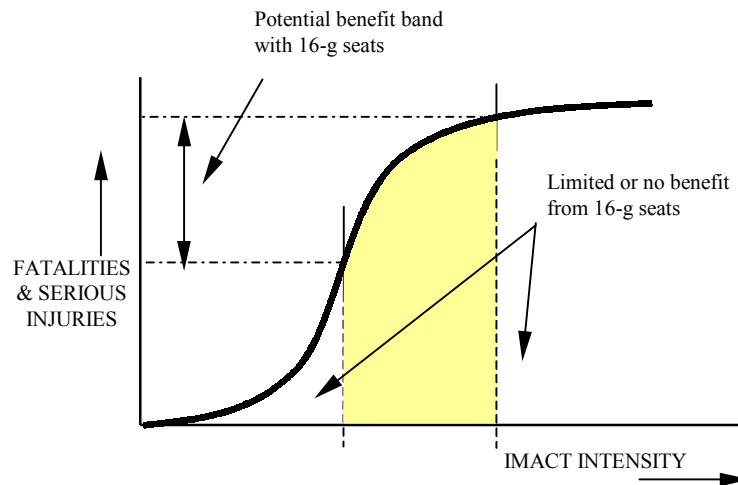

FIGURE 4. POTENTIAL LIVES SAVING WITH 16-g SEATS

This limits the number of ground impact related accidents that would benefit from the introduction of 16-g seats.

It might be expected that the higher the impact intensity the greater the probability of an intense fire. Since the accidents that would benefit from the introduction of 16-g seats are at higher levels of impact intensity, it is hence more likely that there will also be an intense fire.

This secondary threat to survival is extremely significant in the determination of lives to be saved. If passenger impact injuries are prevented with 16-g seats and there is an intense fire threat, then the occupants are likely to perish even if they survive the impact uninjured. If the fire threat could be reduced, then the enhanced impact protection afforded by 16-g seats may allow the occupants to evacuate the fire-threatened area.

For the Bangalore accident sixteen lives might have been saved from the introduction of 16-g seats except that seven of those saved from the impact are likely to have perished as a result of the fire. Therefore, the assessed net savings is nine lives. These assessments are derived from the mathematical and statistical models described in section 4 of the report. The basis for the input data to the model is contained in the appendix for each accident. It was also assessed that 23 fatalities could have been saved in the Cove Neck accident if 16-g seats were installed on the aircraft. A significant factor in this relatively large number is that this accident did not result in an intense fire.

The benefit assessment was based on aircraft compliant with the latest standard of cabin fireworthiness as defined in 14 CFR Part 25 at amendment 72. As fire standards for transport category aircraft are further improved, the potential for increasing the life-saving capability of 16-g seats due to the occupants' reduced exposure to the secondary fire hazard will also be improved.

### **6.2.3 SIGNIFICANCE OF FLOOR DISTORTION**

Due to the extensive disruption to the floor during the impact sequence, a number of accidents analyzed would not have any potential for lives being saved with the introduction of 16-g seats. In some instances, seat detachment is likely to have occurred due to a large degree of floor distortion that would not have been ameliorated by the degree of floor distortion reflected in TSO-C127a, "Rotorcraft, Transport Airplane, and Normal and Utility Airplane Seating Systems," which prescribes the minimum performance standards that the aircraft seating systems must meet. This involves testing the seats to withstand a degree of simulated floor distortion.

### **6.2.4 ACCIDENT DATABASE**

The current database has very few accidents with 100% fatalities. It is unlikely that there are many lives to be saved from the introduction of 16-g seats in accidents of this severity. However, it is feasible that the benefit assessment might increase slightly if accidents of this type were studied.

## **6.3 PREDICTION FOR U.S. 14 CFR PART 121 AIRCRAFT**

Two methods were used to predict the number of lives saved from the introduction of 16-g seats on U.S. aircraft operating under 14 CFR Part 121. As can be seen in tables 6 and 8, the assessed median number of lives that could be saved derived from these two methods was 51 and 23 lives.

### **6.3.1 BENEFIT BASED ON THE ASSESSMENT FOR THE WORLD FLEET**

The intention of carrying out the assessment for the U.S. fleet based on the world fleet of aircraft operating to 14 CFR Part 121, or equivalent, was to improve the accuracy of the prediction by increasing the sample size. This assessment involved factoring the world fleet prediction of benefit by the ratio of all impact-related fatal accidents occurring to aircraft operating to 14 CFR Part 121 or equivalent to those that were N-registered. This method would take into account the lower accident rate experienced in the U.S., but would not take account of any difference in the occupant protection standards that might exist between the two groups of aircraft. However, for the type of accident being analyzed in this study it is considered unlikely that the differences that might exist in occupant protection standards would have a small effect on the benefit prediction.

The benefit, in terms of lives saved, was assessed to be in the range of 33 to 68 with a median of 51 for the fifteen years of accidents studied. The reduction in serious injuries was assessed to be in the range of 28 to 79 with a median of 54.

### **6.3.2 BENEFIT BASED ON U.S. 14 CFR PART 121 ACCIDENTS STUDIED**

This assessment was made based solely on the U.S. aircraft operating under 14 CFR Part 121 for which adequate data are available to make any assessments of the benefit to be derived from the introduction of 16-g seats.

Of the 22 N-registered aircraft operating under 14 CFR Part 121 that involved impact related fatal accidents, only 15 have sufficient data to ascertain whether seat detachment occurred or not. Therefore, the benefit derived from the accidents studied has been factored by 22/15.

The benefit, in terms of lives saved, was assessed to be in the range of 12 to 40 with a median of 23 for the 15 years of accidents studied. The reduction in serious injuries was assessed to be in the range of -1 to 32 with a median of 18.

The assessment based on the world fleet is likely to be the more accurate simply because it is based on a relatively larger sample size. However both samples are small in number and the world fleet prediction is heavily biased by the accident at Cove Neck.

## **7. CONCLUSIONS**

- a. An analysis, based on the currently available data on aircraft accidents over the period 1984 to 1998, was carried out to assess the potential benefit that might result from the introduction of 16-g seats. The benefit was derived in terms of reduction in fatal and serious injuries for aircraft type certificated with 30 or more passenger seats and operating to 14 CFR Part 121. Account has been taken of the reduction in fire threat afforded to the impact survivors by the improved fireworthiness of cabin interiors compliant with the standards defined in 14 CFR Part 25 at amendment 72. Two methods were used. The first is based on

worldwide accident data, and the second is based on US registered aircraft. The results are as follows.

- First Method: Benefit assessment based on the World Fleet

The reduction in fatalities is 51 with a 95 percentile range from 33 to 68 percent, and the reduction in serious injuries is 54 with a 95 percentile range from 28 to 79.

- Second Method: Benefit assessment based on US Part 121 Aircraft

The reduction in fatalities is 23 with a 95 percentile range from 12 to 40, and the reduction in serious injuries is 18 with a 95 percentile range from -1 to 32.

(1) The range of benefit indicated is representative of an error band for the accidents that were studied. It does not give any indication of the likely error resulting from the analysis being based on small samples. This is the reason for the range for reduction in serious accidents not overlapping for the two methods employed.

(2) A negative value for serious injuries is associated with situations where the number of fatal injuries reduced to serious injuries is higher than the number of serious injuries reduced to minor or no injuries. The net outcome is an increase in serious injuries.

(3) Since the sample size for the first method was larger, it is likely to yield the more accurate assessment.

- b. The analytical methods employed are intended to provide as accurate an assessment as is possible with the available data, using the mathematical tools currently in existence. However there will still remain an element of uncertainty associated with assessments of this kind, and this should be borne in mind when making decisions concerning aircraft safety that are predicated on the results of this analysis.
- c. The available data on which the assessment is based limits the accuracy of the predictions.
- d. The fire threat, which is often severe in accidents where 16-g seats are likely to reduce the number of impact fatalities, is a significant factor in terms of the ultimate benefit attained. If significant improvements to occupant protection from fire could be made, this would result in an increase in the assessed benefit from 16-g seats.

- e. Due to the extensive disruption to the floor during the impact sequence, a number of accidents analyzed would not have any potential for lives being saved with the introduction of 16-g seats.
- f. The current database has very few accidents with 100% fatalities. It is unlikely that there are many lives to be saved from the introduction of 16-g seats in accidents of this severity. However, it is feasible that the benefit assessment might increase slightly if accidents of this type were studied.

## **8. REFERENCES**

1. “Analysis of Structural Factors Influencing the Survival of Occupants in Aeroplane Accidents,” CAA Paper 96011, Civil Aviation Authority, London, 1996.



## 9. DEFINITIONS

**Accident Scenario** (Source: International Cabin Safety Research Technical Group)

“That volume of the aircraft in which the occupants are subjected to a similar level of threat.”

**Fatal Injury** (Source: NTSB, ICAO Annex 13, Eighth Edition, July 1994)

“An injury resulting in death within thirty days of the date of the accident.”

**Serious Injury** (Source: NTSB, ICAO Annex 13, Eighth Edition, July 1994)

“An injury which is sustained by a person in an accident and which:

- a. requires hospitalisation for more than 48 hours, commencing within seven days from the date the injury was received; or
- b. results in a fracture of any bone (except simple fractures of fingers, toes, or nose); or
- c. involves lacerations which cause severe haemorrhage, nerve, muscle or tendon damage; or
- d. involves injury to any internal organ; or
- e. involves second or third degree burns, or any burns affecting more than 5 per cent of the body surface; or
- f. involves verified exposure to infectious substances or injurious radiation.”

**Survivable Accident**

“An aircraft accident where there were one or more survivors or there was potential for survival.”

Note: There are several definitions of a survivable accident most of which are similar in concept to that contained in the “Aircraft Crash Survival Guide” published by the U.S. Army Research and Technology Laboratories:

“An accident in which the forces transmitted to the occupant through his seat and restraint system do not exceed the limits of human tolerance to abrupt accelerations and in which the structure in the occupants’ immediate environment remains substantially intact to the extent that a liveable volume is provided for the occupants throughout the crash sequence.”

However this sort of definition has not been adhered to in this analysis for the following reasons:

1. For any particular accident, survivability potential may vary significantly dependent on occupant location.

2. The definition is subjective and hence categorisation will vary dependent on the analyst's assessment of the environment to which the occupants are subjected.
3. Whilst for a particular accident the hazardous environment to which occupants were subjected may have been nonsurvivable this does not infer that improvements would not have resulted in survivors.

For these reasons accidents have been assigned on the basis of the following simplified, nonsubjective criterion:

- At least one occupant survived or there was potential for occupant survival.

The definition of a Survivable Accident excludes:

- Accidents in which there were no survivors and no potential for survival, such as in-flight breakup, collision with high ground, etc.
- Accidents resulting from acts of war, terrorism, and sabotage.

## **APPENDIX A**

### **ACCIDENT DETAILS AND ASSESSMENT**

Appendix A contains, for the accidents analysed, a detailed description (Screen 3 text from the Survivable Accident Database), scenarios, survivability chains, and assessment of potential benefits in terms of reduction of fatalities and injuries if 16-g seats were used. See section 4 in the main report for survivability chains convention.

## ACCIDENT REF: 19850121A

Date:	<b>21-Jan-1985</b>	Flight Phase:	<b>Initial Climb</b>
Aircraft:	<b>L188C</b>	Location:	<b>Reno</b>

### DESCRIPTION OF ACCIDENT

#### RESUME

On 21-Jan-1985 a Galaxy Airlines Lockheed Electra L-188C registered as N5532 was departing from Reno-Cannon International Airport.

Approximately 1 minute later the crew requested to return to the airport because of vibration in the aircraft caused by an improperly closed air start access door. In accordance with the request, the tower controller cleared the flight to make a left turn to a downwind traffic pattern. The flight path and airspeed of the aircraft was not controlled and monitored sufficiently and as a result a stall condition was not detected and the aircraft crashed 1.5 miles from the departure end of the runway.

The aircraft was destroyed by the impact and subsequent fire.

There were 6 crew and 65 passengers on board. Six crew and 64 passengers suffered fatal injuries. One passenger suffered serious injuries.

#### IMPACT

Shortly after takeoff the aircraft experienced a vibration caused by an open air start access door, followed by the onset of aerodynamic stall buffet and impact into the ground.

The aircraft came to rest in a recreational vehicle parking/sale lot adjacent to a main highway. The forward fuselage crown, under body, cockpit, and nose wheel well sustained impact damage. On the forward section, the nose gear strut outer cylinder had separated from the aircraft structure and the braces were sheared.

The main gear was found in the up and locked position. The wheel well area was crushed and compressed around the wheels and tyres.

Sixteen occupants survived the initial impact and apparently were not physically injured. However they were killed by the fire which began immediately upon impact and engulfed the aircraft very rapidly.

The only survivor of the accident, a 17-year-old male, probably survived the accident because he was propelled 40 feet forward of the aircraft. His assumption of a curled up position before the impact may have prevented his head or extremities from striking aircraft or ground structures.

## FIRE

There was no evidence of in-flight fire.

The aircraft's fuel tanks were ruptured on initial impact and were ignited immediately, most probably from contact with hot parts of the engine. The fire propagated rapidly, resulting in near total destruction of the major portions of the aircraft.

Major sections of the fuselage and cockpit area were burned by postimpact fire. The forward fuselage crown, under body, cockpit, and nose wheel well were burned by the fire. A section of the fuselage was also melted.

The wheels and tyres exhibited fire damage.

Sixteen occupants survived the initial impact and apparently were not physically injured. However they were killed by the fire which began immediately upon impact and engulfed the aircraft very rapidly. Other occupants died as a result of the fire and some associated trauma. It is not known how many of these occupants could have survived had there not been a fire; however, the rapidity of the ignition and spread of the fire in this accident prevented their survival. Consequently the postimpact fire played a major role in the cause of the fatalities. The three passengers who survived the crash and the fire did so because they had been thrown from the aircraft upon impact. Nevertheless, two did not survive their injuries and died later.

The only survivor of the accident, a 17-year-old male, probably survived the accident because he was propelled 40 feet forward of the burning aircraft. As a result he was not engulfed in the fire that consumed the aircraft when it came to rest.

The local controller notified the airport Crash Fire Rescue (CFR) units and the airport dispatcher of the accident. The airport dispatcher immediately notified all airport and city rescue units and two medical centres. Information was provided at this time that 71 people were aboard and that the aircraft had over 2,300 gallons of fuel aboard.

Three pieces of equipment were dispatched on the first alarm assignment, and on the way to the scene, the fire department captain ordered a second alarm assignment of two additional pieces of equipment.

The fire at the crash site had burned back about 500 feet to the point of the wing tank rupture. It extended to a furniture store and recreational vehicles that were parked nearby. Propane gas tanks and the small quantities of gasoline in these vehicles exploded, contributing to the overall fire.

The fire was contained in a matter of minutes, with full control accomplished within 30 minutes. None of the early arriving firefighters observed any survivors at the crash site.

## EVACUATION

There were 3 flight crew, 3 cabin crew, and 65 passengers aboard.

The sole survivor, a 17-year-old male, was thrown clear of the aeroplane onto the adjacent highway. However, he sustained first and second degree burns of his face and parts of his body as well as lacerations and contusions. He had been seated in seat 6A, next to his father, who was seated in 6B and was one of the initial survivors. The son told investigators that just before impact he covered his face with his arms and pulled his legs up. He had seen movies on how to prepare for a crash, but he did not think that bending over in a prone position would have helped. He believed that he was thrown through a bulkhead. He landed on a highway, approximately 40 feet forward of the nose. He was still strapped in his seat. He ripped off his seatbelt, got up, and ran as fast as he could towards a field away from the aeroplane.

His assumption of a curled up position before the impact may have prevented his head or extremities from striking aircraft or ground structures.

## AIRCRAFT FACTORS

The aircraft was a Lockheed Electra L-188C registered as N5532 and operated by Galaxy Airlines.

The cabin was fitted with a passenger entry door at the front on the port side and a service door opposite. There was an overwing emergency exit above each wing. The rear of the fuselage was fitted with a passenger entry door on the port side and a service door opposite.

## ENVIRONMENTAL CONDITIONS

The accident occurred during darkness but the sky was clear.

Wind was 290° at 4 kts. Visibility was 12 miles.

## INJURIES TO OCCUPANTS

There were 6 crew and 65 passengers on board. Six crew and 64 passengers suffered fatal injuries. One passenger suffered serious injuries.

The results of the autopsies and the toxicological examinations of the flight crew disclosed no evidence of pre-existing physiological conditions or substances present which could have adversely affected their performance.

Of the three persons who survived the initial impact two died within 2 weeks of the accident. The first died due to massive head injuries, and the second died as a result of thermal injuries. The sole survivor, a 17-year-old male, was thrown clear of the aeroplane onto the adjacent

highway. However, he sustained first and second degree burns of his face and parts of his body as well as lacerations and contusions.

Twenty-seven passengers who had been seated towards the front of the aeroplane died as a result of blunt force trauma caused by the disintegration of the front of the fuselage. The crushing of the front of the aircraft resulted in a loss of occupiable space and structure which precluded any possibility of occupant survival. Three passengers, who had been sitting in the front of the aircraft, died of both burns and impact trauma.

Twenty-two passengers died of burns, the inhalation of the products of combustion, and some associated impact trauma. Fifteen of these individuals were seated in the rear of the aeroplane and 7 in the front. They had survived the initial impact as evidenced by their inhalation of products of combustion. It is unknown if they would have survived their injuries had there not been a fire.

Sixteen passengers died as a result of the fire only and did not suffer identifiable impact trauma. Fourteen of the 16 had been seated toward the rear of the aeroplane. It was noted that the seats at the rear and centre rear (rows 16 to 20) were still attached to the floor, indicating that the crash forces did not exceed 9 g's in the forward direction.

The distribution of causes of death among the passengers was closely related to their location on the aircraft. Most of the passengers killed by blunt force trauma were seated toward the front of the aircraft while passengers killed by the fire were seated toward the rear. Passengers were found to be uniformly distributed throughout the aircraft, which is consistent with information given by the survivor.

### ACCIDENT SCENARIOS AND SURVIVABILITY CHAINS

Information regarding the precise location of the occupants is unknown. However the accident has been broken into three scenarios based on statements made in the accident report.

**Scenario 1** is the area occupied by the flight and cabin crew. It is assumed that all perished as a direct result of the impact.

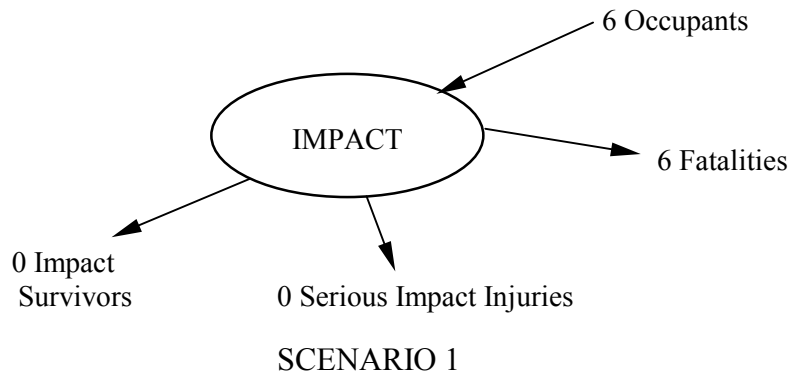

**Scenario 2** is the forward part of the passenger cabin in which it is assessed there were 36 passengers. Based on the statements in the accident report the survivability chain is as follows:

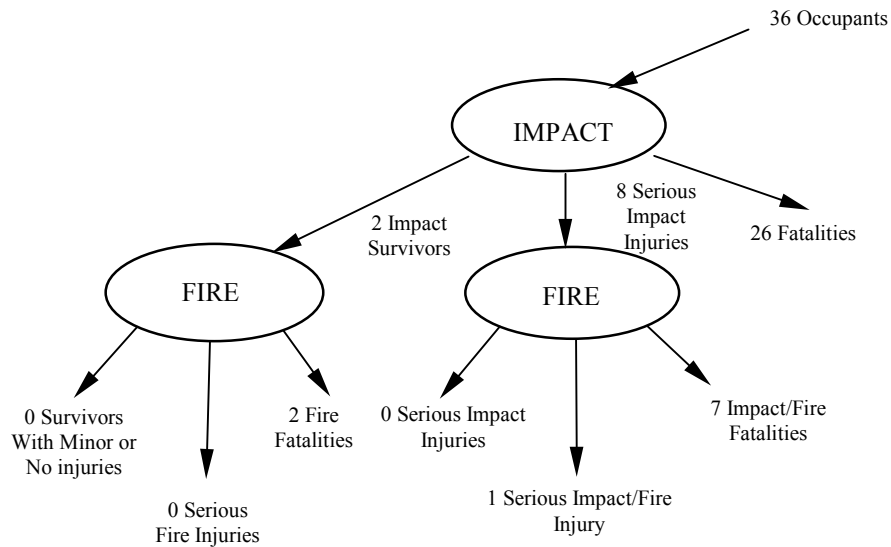

SCENARIO 2

**Scenario 3** is the aft part of the passenger cabin in which it is assessed that the remaining 29 passengers were located. Based on the statements in the accident report the survivability chain is as follows:

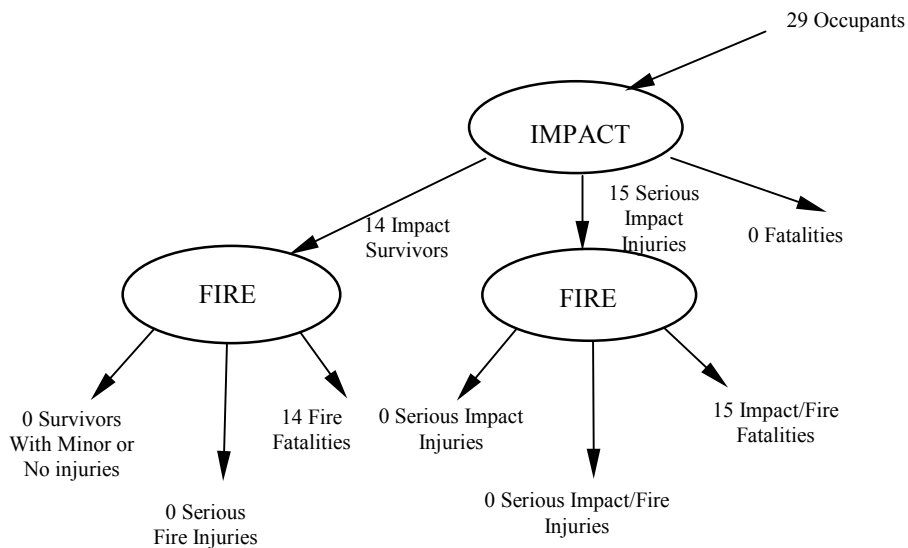

SCENARIO 3



## EFFECT OF INTRODUCING 16-g SEATS

### Scenario 1

This scenario contains only flight and cabin crew seats; therefore, benefit from the introduction of 16-g seats is not applicable.

### Scenario 2

The accident report states: “27 passengers (this is believed to be 26) who had been seated towards the front of the aeroplane died as a result of blunt force trauma, caused by the disintegration of the front of the fuselage. The crushing of the front of the aircraft resulted in the loss of occupiable space and structure which precluded any possibility of occupant survival.” On this basis, it is assessed that no benefit would have accrued from the introduction of 16-g seats.

### Scenario 3

The aircraft would not have been configured to the latest requirements applicable to the fireworthiness of aircraft cabins. From the study described in reference A-1, a factor of circa 50% reduction in fire fatalities resulting from the configuration of an aircraft to the latest fire standards was used. It is further assumed that of this 50%, 25% sustained serious injury from the fire and 25% totally survived the fire.

Furthermore from the analytical study described in reference 1 of the main report, it was suggested: “...the occupants that were injured by the impact had approximately half the chance of surviving the fire than the impact survivors.”

On this basis had the aircraft been configured to the latest standard of fireworthiness requirements the survivability chain for this scenario would be as follows:

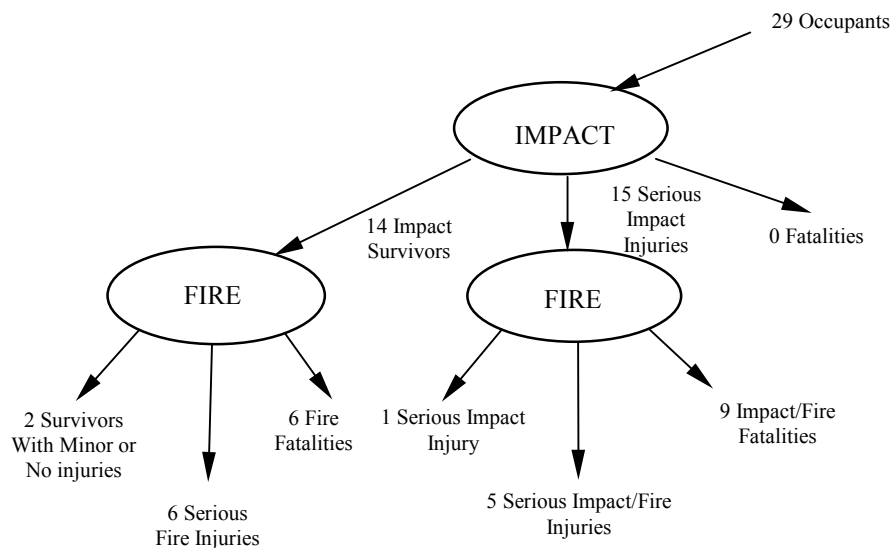

### SCENARIO 3

The accident report states: “16 passengers died as a result of the fire only and did not suffer identifiable impact trauma. 14 of the 16 had been seated toward the rear of the aeroplane. It was noted that the seats at the rear and centre rear (rows 16 to 20) were still attached to the floor, indicating that the crash forces did not exceed 9Gs in the forward direction.”

On this basis, it is entirely feasible that 16-g seats may have prevented all serious injuries. This is taken as the low assessment. The high assessment assumes no benefit and the median assessment is midway between the high and the low.

The high, median, and low predictions of the number of impact fatalities and injuries resulting from the use of 16-g seats are:

	<b>Minor or No Injuries</b>	<b>Serious Injuries</b>	<b>Fatal Injuries</b>
<b>High</b>	<b>14</b>	<b>15</b>	<b>0</b>
<b>Median</b>	<b>22</b>	<b>7</b>	<b>0</b>
<b>Low</b>	<b>29</b>	<b>0</b>	<b>0</b>

## ACCIDENT REF: 19850802A

Date:	<b>02-Aug-1985</b>	Flight Phase:	<b>Approach</b>
Aircraft:	<b>L1011</b>	Location:	<b>Dallas</b>

### DESCRIPTION OF ACCIDENT

#### RESUME

On 2-Aug-1985, at 1805:52 central daylight time, Delta Airlines flight 191, a Lockheed L1011-385-1, N726DA, crashed while approaching to land on runway 17L at the Dallas Fort Worth International Airport, Texas. While passing through the rain shaft beneath a thunderstorm, flight 191 entered a microburst which the pilot was unable to traverse successfully. The aircraft struck the ground about 6300 feet north of the approach end of runway 17L, hit a car on a highway north of the runway killing the driver, struck two water tanks on the airport, and broke apart. Except for a section of the aircraft containing the aft fuselage and empennage, the remainder of the aeroplane disintegrated during the impact sequence, and a severe fire erupted during the impact sequence.

Of the 163 persons aboard, 134 passengers and crewmembers were killed; 26 passengers and 3 cabin attendants survived.

#### IMPACT

The aeroplane touched down initially in a ploughed field about 360 feet east of the extended centreline of runway 17L and 6336 feet north of the runway threshold in a wing level nose-high attitude. The left and right main gear tracks extended about 240 feet beyond the initial touchdown point, and the depth of the left and right main gear tracks was 6 to 8 inches and 5 to 6 inches, respectively. The main gear tracks then disappeared for about 320 feet, reappeared for a short distance, and finally touched down just before the north edge of State Highway 114. The nose gear touched down in the westbound lane of the highway.

The aeroplane knocked over a highway light standard on the north side of the highway and collided with a westbound automobile about 1500 feet beyond the initial touchdown point. The automobile, which was destroyed, contained a small section of No. 1 engine inlet cowling, and metal pieces from the automobile were found in the No. 1 engine compressor inlet. Measurement of the distance between the main landing gear tracks showed that the aeroplane was yawed significantly to the left when it crossed the highway. The first pieces from the aeroplane—pieces of tyre tread—were found just beyond the eastbound lanes of the highway, and two light standards on the southern edge of the westbound lanes were knocked over. The aeroplane breakup, which began as it traversed the highway, continued as it proceeded along the ground toward the two water tanks located on the airport about 1700 feet beyond the highway.

A 45-foot by 12-foot crater was located about 700 feet beyond the highway. The 2.3-foot-deep crater contained pieces from the accessory gearbox of the No. 1 engine, and the No. 1 engine

came to rest about 845 feet beyond the crater. Other components located along the track between the highway and the water tanks included, among others, portions of the nose landing gear, the left horizontal stabiliser, engine components, and pieces of the wing trailing edge flaps and the leading edge slats.

The aeroplane grazed the north water tank and then impacted the south water tank—about 3195 feet beyond initial touchdown—and broke apart. The fuselage, from the nose aft of the fuselage station 1365 (FS 1366), was destroyed. Both wing sections outboard of the engine pylons separated during the breakup. The left wing came to rest in two inverted sections about 1125 feet south of the south water tank. The wing sections and attached sections of the trailing edge flaps and leading edge slats were burned extensively. The outboard section of the right wing came to rest in an inverted position about 775 feet south of the south water tank. The No. 3 engine pylon was attached to the wing and the No. 3 engine was partially attached to the pylon. Both wings left a trail of wing components and burning fuel between the water tank and their final positions.

Portions of the aeroplane were scattered throughout the area extending from the two water tanks to about 1200 feet south of the southernmost tank. Examination of the wreckage showed that all of the recovered structural components in the area adjacent to and south of the water tanks were sooted and damaged to varying degrees by postimpact fire and heat. Examination of the wreckage did not disclose any evidence of preimpact separation or failure.

The investigation team found the aft fuselage section containing the rear cabin and the empennage was in an upright position. Passengers and flight attendants reported that this section came to rest on its left side and was rolled to the upright position by wind gusts after the arrival of the rescue personnel. The section was relatively intact and included the No. 2 engine and associated ducting, the right stabiliser and elevator, and the base of the vertical stabiliser and rudder. The upper 12 feet of the vertical stabiliser and rudder had separated as a unit during the impact sequence and was found about 100 feet north of the aft fuselage section.

#### FIRE

The fuselage forward of seat row 34 including the cockpit disintegrated after the aeroplane struck the water tanks. However, the passengers said fire entered the cabin through the mid-cabin left wall before the aeroplane struck the water tanks, and they tried to shield themselves from the flames as the fire propagated into the cabin.

#### EVACUATION

The aeroplane's passenger cabin contained 46 rows of seats and a total of 302 seats. There were 152 passengers on board flight 191: 71 adult males; 62 adult females; 18 children (24 months or older, but younger than 16 years); and one infant, (younger than 24 months). The ages of the passengers ranged from 20 months to 70 years. In addition, 11 crewmembers were aboard.

The rear cabin section came to rest on its left side. The survivors were either flung from the aeroplane in their seats or released themselves from their seats and exited at the forward end of the separated fuselage section or through the missing left wall. One flight attendant and three

passengers could not escape from the cabin because of injuries and were removed by fellow passengers and rescue personnel. Two other flight attendants had only minor injuries and were able to escape unaided after shouting commands to the passengers to get out of the cabin. The flight attendant seated at the right rear (R-4) exit had difficulty releasing her seatbelt because the buckle was located on her left hip and her weight was on the buckle. The passengers and flight attendants were covered with fuel and some had fuel on their hands and in their eyes, which caused difficulties in climbing down the cabin to the hole created by the missing left cabin wall. Some persons were able to climb downward to the hold over seats while others fell the width of the cabin to the ground.

#### AIRCRAFT FACTORS

The aircraft was a L1011-385-1 registered as N726DA and operated by Delta Air Lines.

The passenger cabin contained 46 rows of seats and a total of 302 seats. The maximum seat layout was nine abreast with two aisles. The cabin was fitted with four passenger doors along each side.

#### ENVIRONMENTAL CONDITIONS

The accident occurred in daylight during a rain storm. Wind was 0 kt and visibility was poor.

#### INJURIES TO OCCUPANTS

Of the 163 persons aboard, 134 passengers and crewmembers were killed; 26 passengers and 3 cabin attendants survived.

The forward cabin containing the cockpit and first 12 rows of passenger seats was destroyed on impact with the water tanks, and there were no survivors from this part of the aeroplane.

The mid-cabin section was also destroyed. Some of the passengers seated in this section, some still in their seats, were ejected onto the ground. Of the 60 passengers seated in this section, 52 were killed. All eight survivors suffered blunt force trauma; seven of the eight survivors sustained thermal injuries in addition to blunt force trauma. One of these eight passengers had been seated in row 21, the remaining seven were seated between rows 27 and 33.

The rear fuselage separated from the aeroplane between seat rows 33 and 34 and the separated rear cabin section contained 33 passengers and four flight attendants. Of these 37 persons, 17, including one flight attendant, died. Of the 20 survivors, 18 received injuries ranging from serious to minor, and 2 received no injuries. None of these survivors sustained thermal injuries.

There was massive disruption of cabin floor, walls, and ceiling of the separated rear cabin section beginning at the point of separation and extending rearward to just forward of row 40. Fifteen persons, including two flight attendants, were seated in this part of the cabin: 10 passengers and 1 flight attendant were killed, 3 passengers were injured seriously, and 1 flight attendant had minor injuries.

Except for the left cabin wall, which was missing, the remainder of the separated rear cabin section from row 40 to row 46 was relatively undamaged. Six passengers seated along the missing left cabin wall were killed. The remaining 16 occupants of this cabin section, including 2 flight attendants, sustained serious and minor injuries, and 2 passengers were not injured.

### ACCIDENT SCENARIOS AND SURVIVABILITY CHAINS

This accident is considered as having eight scenarios, as shown in figure A-1.

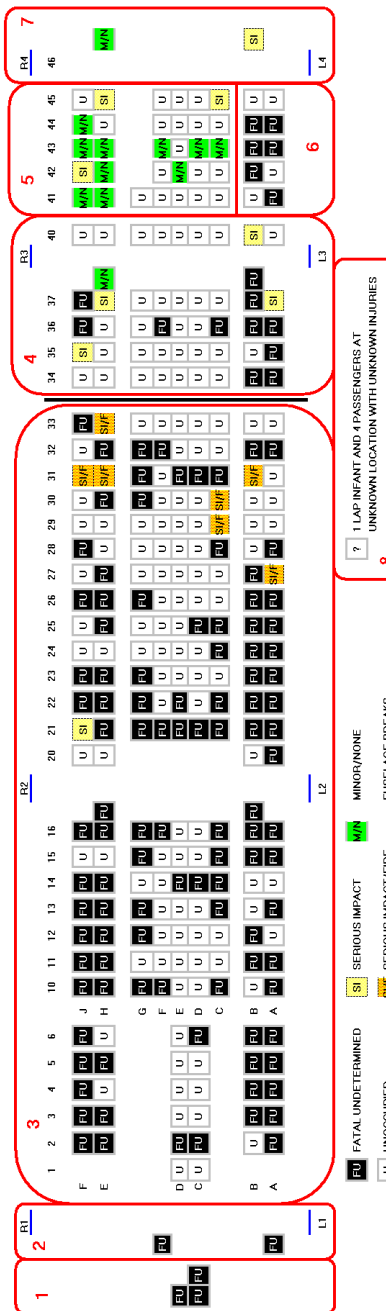
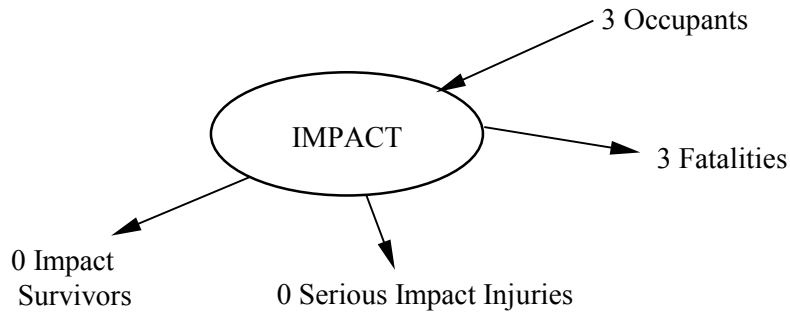

FIGURE A-1. LOCATION OF INJURIES AND SCENARIOS

**Scenario 1** represents the cockpit area containing three flight crewmembers. Since fire was reported only in the mid-section, it has been assumed that the flight crew suffered fatal injuries in the impact.



SCENARIO 1

**Scenario 2** represents the area occupied by the two forward flight attendants. Since fire was reported only in the mid-section, it has been assumed that the forward flight attendants suffered fatal injuries in the impact.

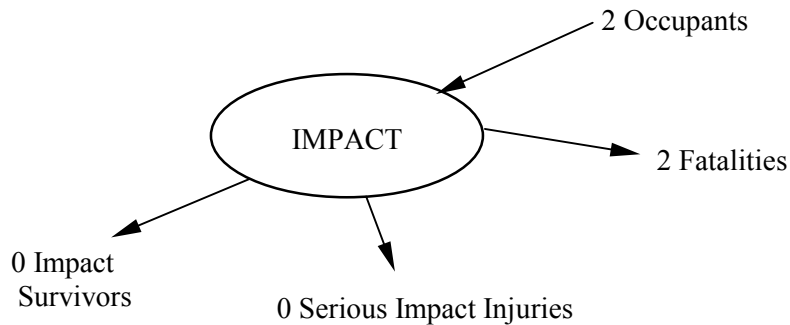

SCENARIO 2

**Scenario 3** represents the main cabin from seat row 1 to seat row 33 where the fuselage break occurred. Full details of occupant injury are not known but this area disintegrated after the aircraft struck water tanks and there is unlikely to be any benefit from the introduction of 16-g seats. Therefore the breakdown of injuries will have no bearing on the outcome of this analysis and all fatalities have been assumed to be from impact forces.

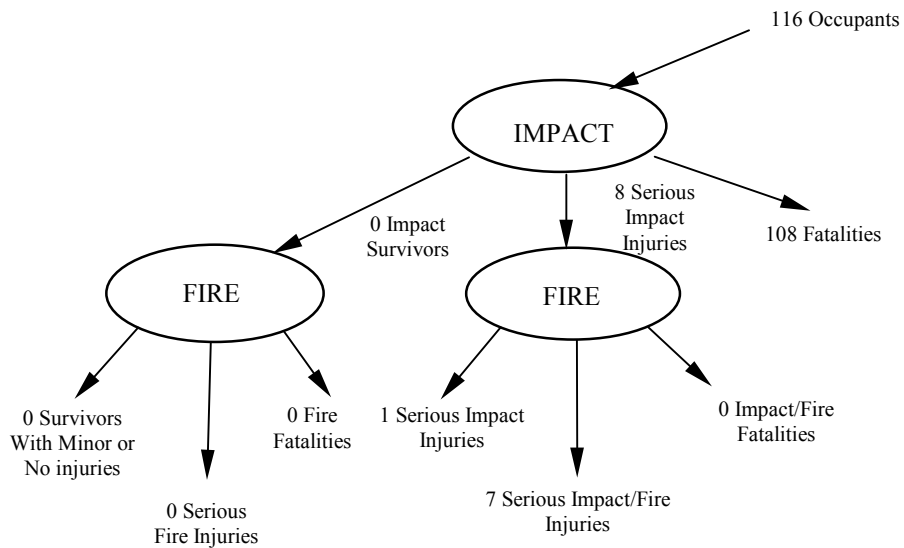

SCENARIO 3

**Scenario 4** represents seat row 34 to seat row 40, located at the front of the rear section and subjected to massive disruption of cabin floor, walls, and ceiling. Full details of occupant injury are not known but due to the extent of the cabin disintegration there is unlikely to be any benefit from the introduction of 16-g seats. Therefore the breakdown of injuries will have no bearing on the outcome of this analysis and all fatalities have been assumed to be from impact forces.

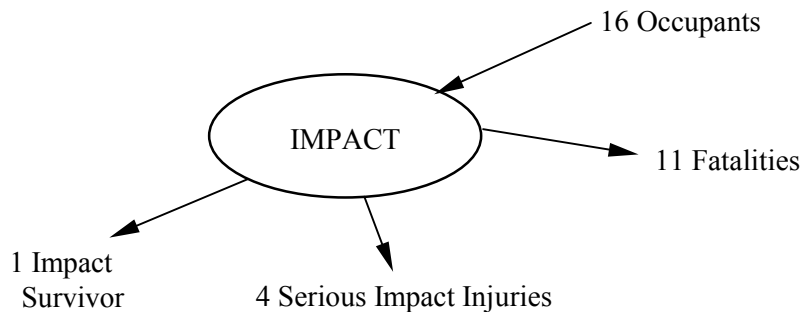

SCENARIO 4

**Scenario 5** represents the middle and right side sections of seat rows 41 to 45, which were relatively undamaged. Three occupants could not escape due to their impact injuries and were removed by fellow passengers and rescue personnel. Ten occupants reported minor or no injuries.



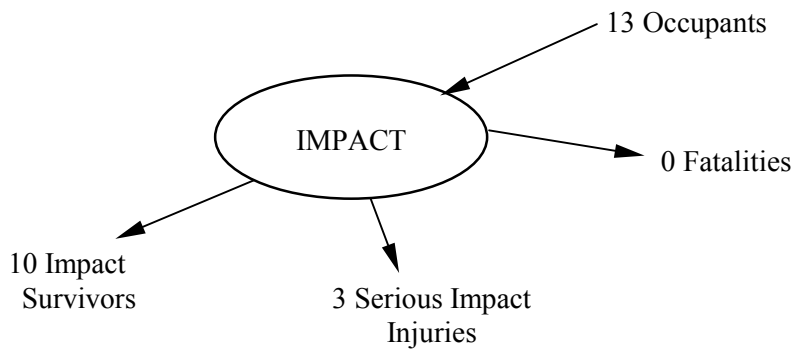

SCENARIO 5

**Scenario 6** represents the left side of seat rows 41 to 45. The left wall was missing and the six occupants who were seated next to the wall suffered fatal injuries and these have assumed to have been caused by the impact forces that removed the wall.

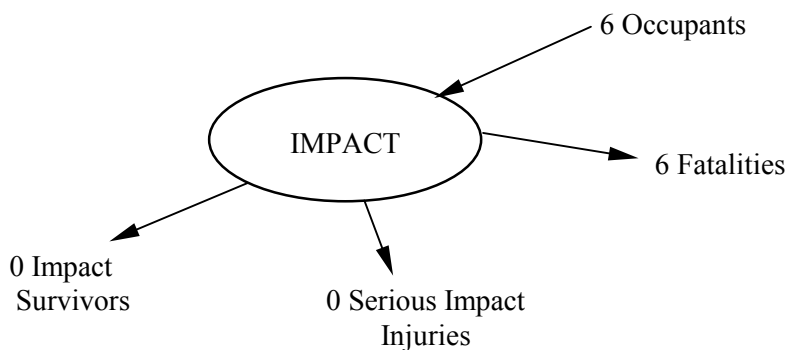

SCENARIO 6

**Scenario 7** represents the area containing the two rear flight attendants. One suffered serious injuries due to the impact and the other escaped with minor or no injuries.

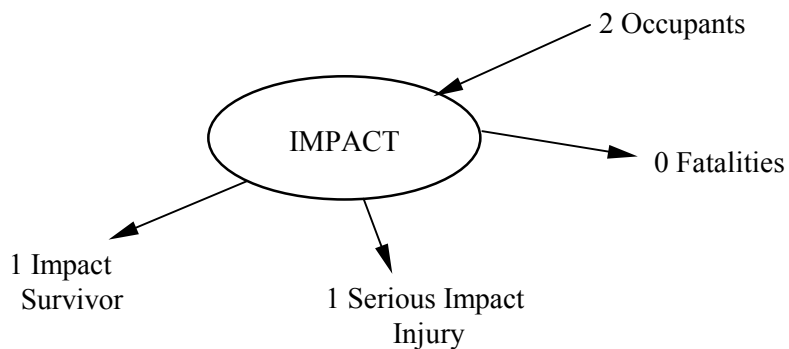

SCENARIO 7

**Scenario 8** contains the five occupants for which seat location and injury were unknown. Absence of information results in the following simplified survivability chain. It was reported that 26 passengers and 3 cabin attendants survived the accident. However in figure A-1 the injury location diagram only identified 25 passengers and 3 cabin attendants. Therefore, 1 of the unknown seat location passengers must have received minor or no injuries since it was not significant enough to be reported officially.

The four unknown seat location passengers have been assumed to have died from the impact. This is consistent with the destruction of the aircraft.

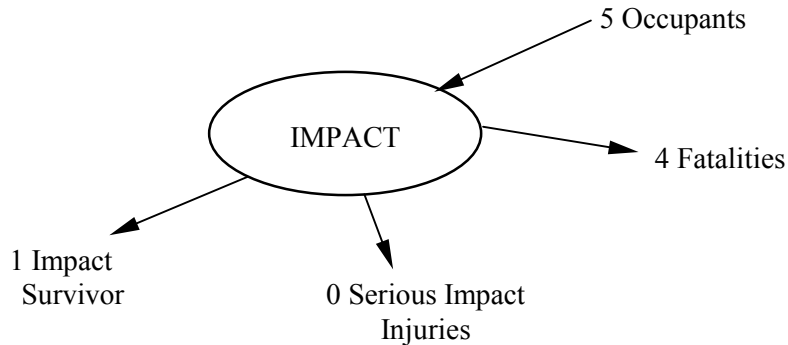

SCENARIO 8

### **EFFECT OF INTRODUCING 16-g SEATS**

#### Scenario 1

This scenario contains only flight crew seats and therefore benefit from the introduction of 16-g passenger seats is not applicable.

#### Scenario 2

This scenario contains only cabin crew seats and therefore benefit from the introduction of 16-g passenger seats is not applicable.

#### Scenario 3

The fuselage from the nose aft to seat row 33 disintegrated after the aircraft struck the water tanks. Some passengers were ejected from the cabin while still in their seats. It is therefore assessed that with the massive disruption to the aircraft structure in this area, there would be no benefit from the introduction of 16-g seats.

#### Scenario 4

There was massive disruption of the cabin floor, walls, and ceiling. Some survivors were flung from the aircraft in their seats. It is therefore assessed that with the massive disruption to the aircraft structure in this area, there would be no benefit from the introduction of 16-g seats.

### Scenario 5

Other than the left side, the cabin in this scenario was relatively undamaged. The three seriously injured occupants could not escape due to their impact injuries and the low assessment assumes that all three would have been restrained and protected by 16-g seats such that they only suffered minor or no injuries. The high assessment is based on the assumption that their injuries were not related to seat failure and that the introduction of 16-g seats would have provided no benefit. The median assessment is based on the average of the high and the low assessments.

The high, median, and low predictions of the number of impact fatalities and injuries resulting from the use of 16-g seats are:

	<b>Minor or No Injuries</b>	<b>Serious Injuries</b>	<b>Fatal Injuries</b>
<b>High</b>	<b>10</b>	<b>3</b>	<b>0</b>
<b>Median</b>	<b>12</b>	<b>1</b>	<b>0</b>
<b>Low</b>	<b>13</b>	<b>0</b>	<b>0</b>

### Scenario 6

The six fatalities located against the missing side wall are assumed to have been killed by the impact that removed the wall and therefore no benefit was assessed for the use of 16-g seats in this area.

### Scenario 7

This scenario contains only cabin crew seats and therefore benefit from the introduction of 16-g passenger seats is not applicable.

### Scenario 8

Due to lack of information, it is not possible to assess any benefits in this scenario. However since the fatally injured occupants were in all probability located in scenarios 3, 4, or 6 it is likely that there would be no benefit to be gained from 16-g seats.

## ACCIDENT REF: 19870816A

Date:	<b>16-Aug-1987</b>	Flight Phase:	<b>Takeoff</b>
Aircraft:	<b>DC9</b>	Location:	<b>Detroit</b>

### DESCRIPTION OF ACCIDENT

#### RESUME

On 16-Aug-1987 a Northwest DC-9-82 registered as N312RC was taking off from Detroit Metropolitan Wayne County Airport, Romulus, Michigan. The crew had not used the taxi checklist and as a result the flaps and slats were not extended for takeoff.

According to witnesses, the aircraft began its takeoff rotation about 1200 to 1500 feet from the end of the runway and lifted off near the end of the runway. After lift-off, the wings of the aircraft rolled to the left and the right about 35 deg in each direction. The aircraft collided with obstacles northeast of the runway when the left wing struck a light pole located 2760 feet beyond the end of the runway. Thereafter the aircraft struck other light poles, the roof of a rental car facility, and then the ground. It continued to slide along a path aligned generally with the extended centreline of the takeoff runway. The aircraft broke up as it slid across the ground and postimpact fires erupted along the wreckage path. Three occupied vehicles on a road adjacent to the airport and numerous vacant vehicles in a rental car parking lot along the aeroplane's path were destroyed by impact forces and/or fire.

Of the persons on board flight 255, 148 passengers and 6 crewmembers were killed; the only survivor, a 4-year-old child, was seriously injured.

#### IMPACT

After takeoff, the wings of the aircraft rolled to the left and the right about 35 deg in each direction. The aircraft collided with obstacles northeast of the runway when the left wing struck a light pole located 2760 feet beyond the end of the runway. Thereafter the aircraft struck other light poles, the roof of a rental car facility, and then the ground. It continued to slide along a path aligned generally with the extended centreline of the takeoff runway.

The wreckage was distributed over a 3000-foot crash path which traversed a railroad embankment and overpass and two interstate highway overpasses. Except for two fairly large fuselage sections, the cabin area disintegrated during the crash sequence. The cabin components were deformed severely and fragmented by the impact forces. The main entry door, the rear galley and ventral doors, and the overwing emergency exits were separated from their frames. All of the passenger seats were separated from the fuselage and were scattered along the wreckage path. Most seatbacks were separated from the seat bottoms.

The fuselage structure had disintegrated and was scattered throughout the wreckage path. Only two relatively large pieces of structure remained: the forward area from fuselage station (FS) 7 to FS-541 and the aft area from FS-1007 to FS-1338.

The left side of the cockpit was destroyed. The left and right side sliding windows were deformed and separated from the cockpit structure. The windshield and side windows were found along the wreckage path. The captain's and first officer's seats separated during the impact sequence.

The forward fuselage section and cockpit were battered heavily and the top and upper sections broke open and tore away during the accident sequence. The cockpit area also broke open and the roof and side walls tore away. This section also had some localised burn damage.

The aft section contained the main rear wall of the landing gear well aft to the rear pressure bulkhead and the auxiliary power unit (APU). The front portion of the section was lying upright with the upper cabin section broken and burned away. The exposed cargo area was empty and gutted by fire. The APU section was not damaged heavily by either fire or explosion and the APU was relatively intact.

#### FIRE

As the left wing struck the light pole, the aircraft caught fire. The postimpact fire contributed to the destruction of the aircraft.

Most of the interior components were damaged to varying degrees by fire.

#### EVACUATION

Due to the intense impact there was no evacuation. The only survivor was found in the wreckage beneath one of the highway overpasses. According to the company's passenger manifest, she had been assigned seat 8F.

#### AIRCRAFT FACTORS

The aircraft was a DC-9-82 registered as N312RC and operated by Northwest Airlines. It was configured for a 2-person flight crew and 143 passengers. The passenger cabin was configured with 12 first class passenger seats: three rows of double seats on the left and right sides of the cabin. The 131 tourist class seats, including a designated flight attendant seat (29D) consisted of 28 rows of triple seats on the right side and 24 rows of double seats on the left side of the cabin. A double occupancy aft facing flight attendant seat was on the aft left side of the cockpit rear bulkhead; a double occupancy forward facing flight attendant seat was located on the ventral airstairs aft exit door.

## ENVIRONMENTAL CONDITIONS

The accident occurred at dusk and the prevailing weather conditions at the time of the accident were haze with a temperature of 26°C. Wind was 7 kt.

## INJURIES TO OCCUPANTS

Of the 6 crew and 149 passengers aboard, 6 crew and 148 passengers suffered fatal injuries. The only survivor was a 4-year-old girl who was found in the wreckage with serious injuries consisting of 3rd degree burns, a skull fracture, fractures of the left femur and clavicle and multiple lacerations, abrasions, and contusions.

The captain and first officer suffered severe blunt force trauma. External examination of the occupants showed that all had sustained multiple injuries. Autopsies of the victims were not performed in view of obvious injuries which caused instantaneous death.

Ten percent of the victims sustained burns and all fire injuries were postmortem.

## ACCIDENT SCENARIOS AND SURVIVABILITY CHAINS

Due to the massive disintegration of the fuselage structure, this accident was considered as a single scenario, encompassing the whole cabin.

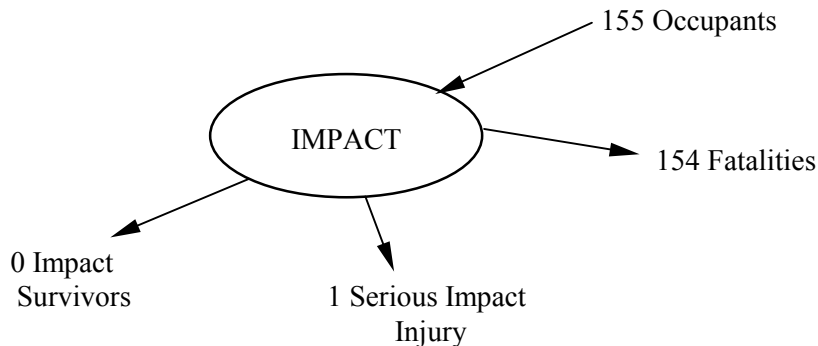

## EFFECT OF INTRODUCING 16-g SEATS

This accident involved a considerable impact and the cabin area disintegrated during the crash sequence. It was reported that all of the passenger seats were separated from the fuselage and were scattered along the wreckage path. In addition, external examination of the occupants showed that all had sustained multiple injuries. Therefore, due to this large amount of structural disruption, it is assessed that the introduction of 16-g seats would not have provided any additional benefit in this accident.

## ACCIDENT REF: 19871115A

Date:	15-Nov-1987	Flight Phase:	Takeoff
Aircraft:	DC9	Location:	Denver

### DESCRIPTION OF ACCIDENT

#### RESUME

On 15-Nov-1987 a Continental Airlines DC-9-14 registered as N626TX was delayed in snow conditions at Stapleton International Airport, Denver, while awaiting take off and did not deice for a second time.

Following a rapid rotation, control of the aircraft was lost and as a result it crashed off the right side of the runway and came to rest inverted. There was a fireball inside the fuselage for a short time during the impact sequence.

The 2 pilots, 1 flight attendant, and 25 passengers were killed. Fifty-two passengers and two flight attendants survived and either escaped or were extricated from the aircraft. Some of the passengers were trapped in the wreckage until they could be freed by rescuers.

#### IMPACT

During the impact sequence the left wing was destroyed, the fuselage separated into two sections (at seat row 9), and the empennage separated. The forward fuselage came to rest on its left side and the remainder of the cabin came to rest inverted. The ground was level and snow covered.

There was extensive disruption inside the cabin. The galleys were partly detached and distorted. Luggage bins and seats had become broken and detached. Some floor tracks were missing.

Three major ground scars were found at the accident site. The nearly intact empennage/tail cone section of the aircraft was located approximately 250 feet down from the third scar. It was inverted and coated with soot but showed no signs of thermal damage. The left horizontal stabiliser tip and left elevator tip were missing. Fragments from these components were found earlier along the wreckage path.

The fuselage and right wing were located approximately 200 feet down from the empennage. The forward portion of the fuselage, which had split at station 446, was resting on its left side. The left side was badly damaged. Much of the exterior skin and underlying structure was torn away and found along the wreckage path. The right side of the fuselage was distorted and dented in several places near the forward baggage door. The aft portion of the fuselage was aligned with the forward part of the fuselage and resting inverted. The section of fuselage just aft of the break was collapsed within inches of the cabin floor. The portion of fuselage just aft of the break was collapsed to the level where the forward part of the engine was resting on the ground.

## FIRE

A fireball existed in the fuselage for a short time which started at row 11, moved down the aisle to row 16, and was gone very quickly. The fireball probably resulted from ignition of residual centre fuel tank fuel, extinguishing itself rapidly and did not affect passenger escape. The snow and dirt that entered the cabin during the impact sequence may have prevented the fireball from igniting anything in the cabin.

The moderate snowfall and cold temperature mitigated fuel vaporisation and further prevented a sustained postcrash fire.

Several residual fires were evident after the aircraft came to rest but these were quickly extinguished by firefighters and caused only minor damage to the airframe.

During the evacuation and extraction of trapped passengers there was dripping fuel but no fire.

Both Crash/Fire/Rescue (CFR) stations were notified of the accident and responded to the scene within several minutes with five CFR vehicles and 12 firefighters. Numerous structural firefighting and rescue units also responded from the nearby city and county. Firefighters extinguished several individual localised fires at the root area of the left wing.

## EVACUATION

There were 2 flight crew, 3 cabin crew and 77 passengers aboard. The cabin was configured to accommodate 83 passengers.

The flight attendant seated on the left side of the aft jumpseat was positioned in the inverted part of the fuselage near the rear tailcone exit. She tried but failed to remove emergency equipment from the overhead bins which were underneath her feet. She passed two emergency flashlights into the cabin as it was dark. When the tailcone exit had been opened by a male flight attendant and some passengers, she sent a 6-year-old girl and a couple with a baby first. She was standing on the overhead bins so that people could get by her to get out. Everyone was climbing over her so she got out of the way and exited.

The male flight attendant seated on the right side of the aft jump seat realised that the aircraft was going down and tried to assume the brace position but the force on him was too great and he could not move his hands. He yelled commands “Bend Over, Heads Down” but wasn’t sure he could be heard because the noise was so loud. When the aircraft came to a stop he tried to open the rear tailcone exit but due to back pain he realised that he would not be able to open the door alone. He gained the assistance of a few passengers to clear away debris and open the door. They eventually got the door removed, turned it on its side, and pushed it out of the aircraft. He estimated that it took 10 minutes to get the door open.

A number of passengers were trapped in the wreckage, some up to 5 hours, before being freed by rescuers.

The three evacuation slides had not been used during evacuation.



Emergency lights were not illuminated in the rear cabin after the aircraft came to rest and during evacuation. Later examination showed that the emergency floor level lighting strip was displaced from the floor and the wires were separated. In the forward cabin, floor path emergency lights reportedly illuminated and remained so for a number of hours after the accident.

The first aid kit could not be removed from its mounting bracket because the aft left bulkhead has shifted forward and jammed the first aid kit in the bracket.

#### AIRCRAFT FACTORS

The aircraft was a DC-9-14 registered as N626TX and operated by Continental Airlines.

The cabin was divided into first class and coach sections and had a total of 83 passenger seats. The first class section contained two rows of double occupancy seat units for a total of eight seats. The seats had leather upholstery and were installed at 34-inch seat pitch. The coach cabin had 15 rows of double occupancy seat units on the left of the aisle and 15 rows of triple occupancy seats on the right side of the aisle for a total seating capacity of 75. The coach seats were installed at either 30- or 31-inch seat pitch.

The first class and coach cabins were separated by two cabin dividers, one on each side of the aisle.

An aft facing double occupancy flight attendant jumpseat was mounted on the left rear side of the cockpit bulkhead adjacent to the forward main cabin door. A forward facing double occupancy flight attendant jumpseat was mounted on the aft pressure bulkhead between the two lavatories.

Seat cushion fire blocking was installed on passenger and flight attendant seats.

The aircraft was fitted with seven emergency exits: two cockpit window exits, the main cabin door, the forward galley door, two window exits (one above each wing), and a tailcone exit.

#### ENVIRONMENTAL CONDITIONS

The accident occurred at 14:16 hours Mountain Standard Time in daylight.

The prevailing weather conditions at the time of the accident were snow precipitation with a temperature of -2°C. Wind was 10 kt.

#### INJURIES TO OCCUPANTS

Of the 5 crew and 77 passengers aboard, 3 crew and 25 passengers suffered fatal injuries. Eleven passengers and three crewmembers died of multiple blunt force traumatic impact injuries. Five passengers died of head injuries and nine passengers died of traumatic asphyxia.

Survivors' injuries consisted of fractures; closed head injuries; 2nd degree burns; contusions to internal organs; and multiple abrasions, contusions, and lacerations.

In spite of the brevity of the cabin fireball, 10 survivors and 6 deceased passengers received first or second degree burns.

**ACCIDENT SCENARIOS AND SURVIVABILITY CHAINS**

This accident is divided into six separate scenarios, as shown in figure A-2.

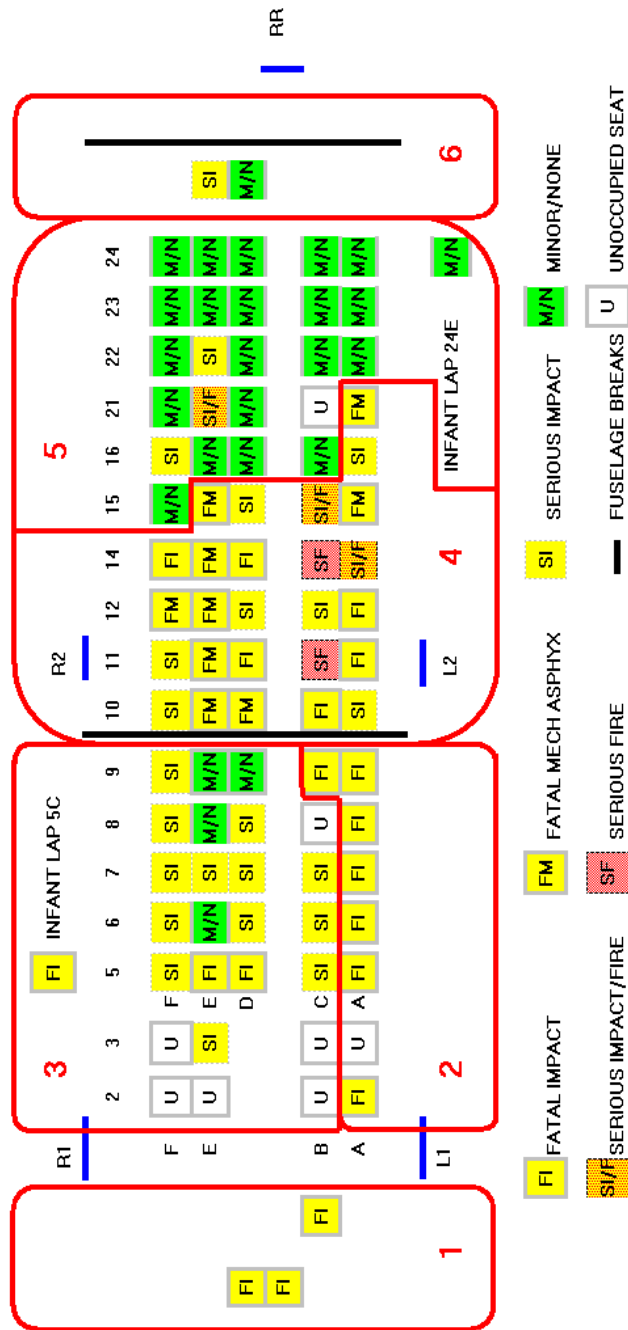
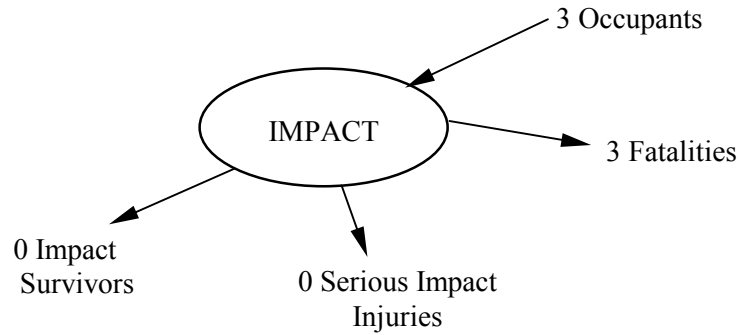

FIGURE A-2. LOCATION OF INJURIES AND SCENARIOS

**Scenario 1** contains the flight deck and the vestibule where two flight crew and one cabin attendant died from impact injuries.



SCENARIO 1

**Scenario 2** contains the forward left side of the fuselage, seats 2A to 9A and 9C, where there were seven impact fatalities. Conditions for passengers seated in these seats are considered nonsurvivable due to the severe damage in this area. The forward fuselage came to rest on its left side and it was badly damaged. This included loss of some areas of the floor and ceiling. Much of the exterior skin and underlying structure was torn away and found along the wreckage path.

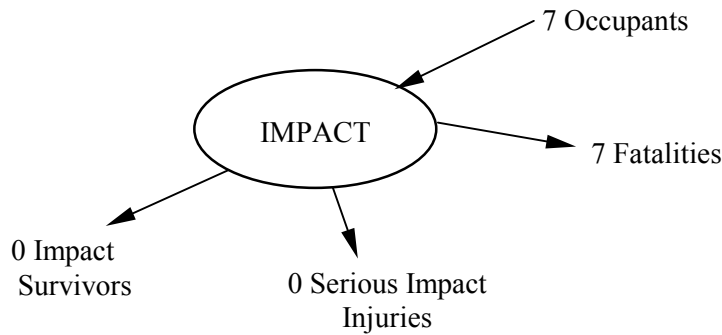

SCENARIO 2

**Scenario 3** contains rows 2 to 9 on the right side and seats 2B to 8B. The right side of the fuselage was distorted and dented in several places near the forward baggage door. Some passengers were thrown out of the cabin. There were 20 passengers in this section and 2 died from impact injuries, 13 suffered serious impact injuries, and 4 received minor or no injuries.

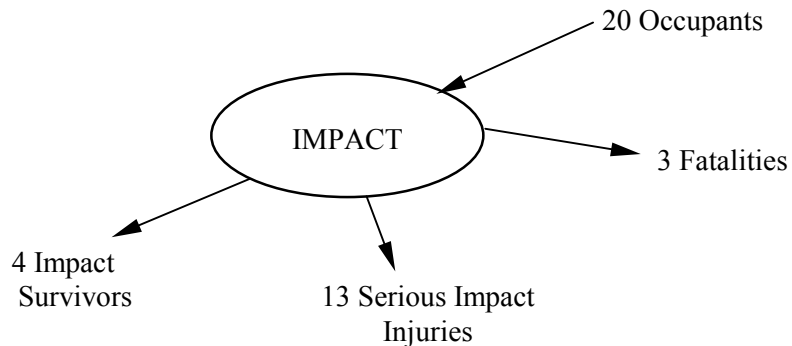

SCENARIO 3

**Scenario 4** contains rows 10 to 14, seats 15A, C, D, and E, 16A, and 21A. This section of the fuselage came to rest inverted. There were 26 passengers in this scenario. Nine died from mechanical asphyxiation, six died from impact injuries, seven suffered serious impact injuries, two suffered serious fire burns, and two suffered serious impact and fire burns.

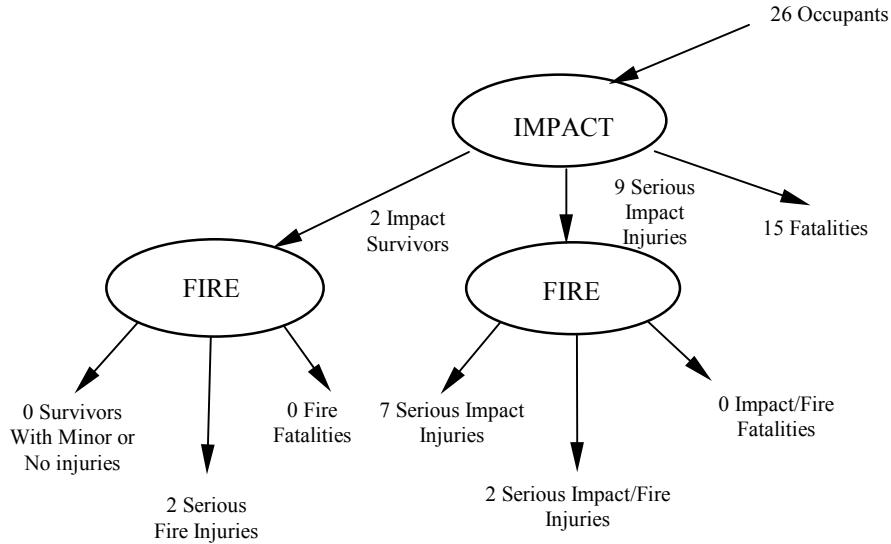

SCENARIO 4

**Scenario 5** contains passenger seats 15F, 16C, D, E, and F, 21C, D, E, and F and rows 22 to 24. This section of the fuselage came to rest inverted. There were 24 passengers in this scenario. Two suffered serious impact injuries, 1 suffered serious impact and fire burns, and 21 received minor or no injuries.

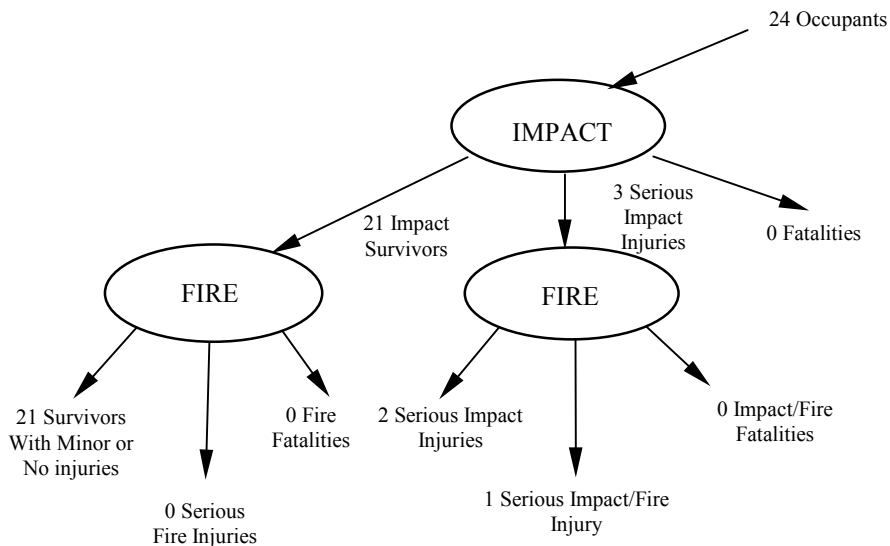

SCENARIO 5

**Scenario 6** contains the two flight attendants stationed at the rear of the aircraft. One flight attendant sustained serious impact injuries and the other received minor or no injuries.

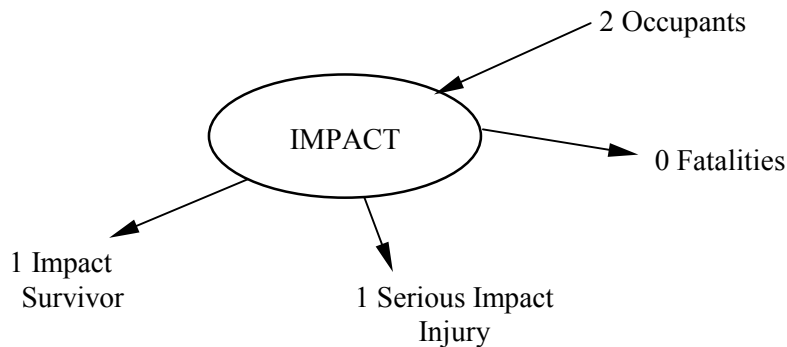

SCENARIO 6

### **EFFECT OF INTRODUCING 16-g SEATS**

#### **Scenarios 1 and 6**

These scenarios contain only flight and cabin crew seats; therefore benefit from the introduction of 16-g passenger seats is not applicable.

#### **Scenario 2**

Due to the extensive damage in this scenario, it is assessed that all occupants in a window seat were subjected to immense impact forces and died as a direct result. Therefore, it is concluded that 16-g seats would not have any added benefits to this scenario.

#### **Scenario 3**

In this scenario, the right side of the fuselage was distorted and dented in several places near the forward baggage door. The accident report also stated that seats in rows 2 to 6 were detached and the floor was missing in rows 7 to 9. Some passengers were thrown out of the cabin in their seats and some were trapped in the wreckage.

Therefore, introducing 16-g seats to the aircraft might alter the injury pattern in this scenario. The low and median assessments are based on 16-g seats saving the two fatalities in seats 5D and 5E but not the infant in 5C. The infant was in his mother's lap and was not strapped down. It is assumed that the two fatalities died from head injuries as a result of seat detachment. Their heads impacted on to the divider panel in front of them.

A reduction in the number of serious impact injuries may also have been gained. However since the floor was missing in rows 7 to 9 it is most likely that the injuries sustained in this area would be unchanged.

The high assessment assumes that no lives or injuries would be saved with 16-g seats.

The low assessment is based on all injuries in this scenario being avoided except for the in-lap infant in 5C.

The high, median, and low predictions of the number of impact fatalities and injuries resulting from the use of 16-g seats are:

	<b>Minor or No Injuries</b>	<b>Serious Injuries</b>	<b>Fatal Injuries</b>
<b>High</b>	<b>4</b>	<b>13</b>	<b>3</b>
<b>Median</b>	<b>12</b>	<b>7</b>	<b>1</b>
<b>Low</b>	<b>19</b>	<b>0</b>	<b>1</b>

#### Scenario 4

In this scenario, the fuselage was inverted and in an area of extreme compression from rows 10 to 15. All occupants in this section required extrication. The fuselage was progressively less compressed toward the rear of the aircraft from row 15 onward.

There were seat failures in this section during the impact sequence; however, a large number of seats were removed from the aircraft by the rescuers during the extrication of trapped passengers.

It is believed that the port side of this scenario was less compressed than the starboard side. There were more occupants that died from mechanical asphyxiation on the starboard side. The low assessment is based on 16-g seats saving the three impact fatalities on the port side in seats 10B, 11A, and 12A. It is assumed that they died from head injuries as the result of the impact. It is also assumed that the serious impact injuries sustained by the five passengers on the port side may have been prevented.

The high assessment assumes that no lives or injuries would be saved with 16-g seats.

The median assessment is taken as being midway between the high and the low assessments.

The high, median, and low predictions of the number of impact fatalities and injuries resulting from the use of 16-g seats are:

	<b>Minor or No Injuries</b>	<b>Serious Injuries</b>	<b>Fatal Injuries</b>
<b>High</b>	<b>2</b>	<b>9</b>	<b>15</b>
<b>Median</b>	<b>5</b>	<b>8</b>	<b>13</b>
<b>Low</b>	<b>7</b>	<b>7</b>	<b>12</b>

Although the aircraft was fitted with fire-blocking seat cushions, it is unlikely that the cabin materials complied with the low heat release properties required by CFR 14 Part 25 post amendment 60. However since the fire injuries appear to have been caused by the fireball that probably resulted from ignition of residual centre tank fuel, it is considered that enhanced fire properties of cabin materials would not have ameliorated the fire injuries.

#### Scenario 5

This section of the fuselage was inverted and was progressively less compressed toward the rear of the aircraft from row 15 onward. Therefore, most of the survivors were seated in this scenario and all occupants in this section required extrication. At the separation, the distance from the cabin floor to the cabin ceiling may have been less than 4 feet 5 inches.

There were seat failures in this section during the impact sequence; however, a large number of seats were removed from the aircraft by the rescuers during the extrication of trapped passengers.

Despite seat failures in this section, it is considered that 16-g seats would not have altered the injury pattern in this scenario. Those passengers sustaining impact injuries were all located on the starboard side toward the front of the scenario where the fuselage collapse was greatest.

## ACCIDENT REF: 19880415A

Date:	15-Apr-1988	Flight Phase:	Approach
Aircraft:	DHC8	Location:	Seattle

### DESCRIPTION OF ACCIDENT

#### RESUME

On 15-Apr-1988 a Horizon Air DHC-8-102 registered as N819PH was making a precautionary landing at Seattle-Tacoma International Airport, Seattle, Washington.

After lowering the landing gear on final approach, a massive fire broke out in the right engine nacelle. After the first officer shut down the engine, the captain proceeded to land the aircraft; however, shortly after touchdown, the crew realised that almost all directional control and braking capability was lost. The aircraft departed the paved surface of the runway, crossed a grass median area, entered the paved ramp area and struck a runway designator sign, several baggage carts and two jetways. The aircraft came to rest against another jetway.

The aircraft received substantial damage because of the engine fire and was subsequently destroyed during impact with objects and structures on the ramp.

There were 3 crew and 37 passengers aboard. Four passengers suffered serious injuries. Three crew and 33 passengers received minor or no injuries.

#### IMPACT

Shortly after takeoff, with the captain at the controls, the aircrew noted a power loss on the right engine. The captain made the decision to return to Seattle for a precautionary landing.

The first officer stated that as he was scanning for traffic out of the right side window during the turn to final approach, he observed a "flash" from the right engine. The first officer then observed that the centre access panel on the left side of the right nacelle was missing and that an orange/yellow flame was in that area.

The flight attendant delivered her emergency landing briefing that included two different brace positions because of the seating arrangement of the aircraft.

About 1/4 mile from the runway and about 100 feet above the ground, the crew began to notice a significant change in the controllability of the aircraft. The aircraft landed on the runway and then veered off to the left. The first officer advised the tower that the aircraft was out of control and manually locked his and the captain's shoulder harnesses.



As the aircraft rolled onto the ramp pavement after crossing grass areas and taxiways on the airport, it struck and destroyed a frangible lighted runway designator sign. By this juncture, the aircraft heading had changed another 2 deg to the left. Neither crewmember felt any deceleration.

As the aircraft entered the ramp area south of the tower, it struck jetway B7 damaging the outboard left wing. After striking the first jetway, the aircraft struck jetway B9 causing the outboard left wing to separate from the aircraft. The aircraft struck and destroyed several baggage carts and pieces of ground equipment as it traversed the area between jetways B7 and B9 and came to rest against jetway B11.

A large hole was ripped in the right side of the fuselage during impact with the ground equipment. It extended from the floor level of the cabin to above the window line and from the right under wing emergency escape hatch forward to the right emergency door. The aircraft came to rest with its fuselage pointing east and the right wing penetrating the jetway boarding tunnel.

Neither the captain's nor the first officer's seats were displaced during the accident sequence. The shoulder harnesses on both seats were intact and operational; however, they were frayed and abraded at the "Y" junction to about 12 inches above that junction. The plastic covers over the shoulder harness guide rollers on the backs of both seats were missing. In addition, the cockpit jumpseat hold-up strap in the cockpit was frayed and split. The jumpseat was held in the stowed position by placing this split strap over the jumpseat hold-down stud on the hinged seat. The crash axe was found on the floor behind the left seat and the aft left cockpit window was cracked.

Seats 1DE, 2DE, and 3DE, in the area most heavily damaged during impact with ground equipment, were torn loose during the accident sequence. The passengers in seats 3D and 3E were ejected from the aircraft while still buckled in their seats. The forward aft outboard leg attachments of seats 9E separated from the floor track. All other passenger seats as well as the flight attendant's seat remained attached to the aircraft floor; although some passenger seats sustained some degree of impact deformation. The overhead compartments over seats 2DE and 3DE were open, and all other overhead compartments were closed.

A beverage cart was found on its side in the aisle between seat rows 3 and 4. The secondary securing latch for the cart was unlatched. Structural continuity of the floor area in the cart stowage area was lost around the "mushroom" floor lock doubler. The floor covering was torn away from the doubler. The secondary securing latch for the lower compartment door was also unlatched.

A closet/wardrobe was installed on the left side of the cabin, forward of the main cabin door. A placard on the wardrobe read, in part, "100 lbs. floor load limit." Objects removed from this wardrobe following the accident included catering boxes, beer, wine and liquor containers, a suitcase, and a small, portable mechanical carpet sweeper. The objects (not including the carpet sweeper) weighed 146 lbs. DeHavilland Service Bulletin 8-25-35 called for a 1/4 turn latch and until fitted the wardrobe should be restricted to hanging items only. The 1/4 turn latch had not been fitted and the wardrobe door separated completely during the accident.

## FIRE

Due to improper installation of the high-pressure fuel filter cover, a massive fuel leak occurred which subsequently fed an in-flight engine fire.

Statements from the first officer and several passengers revealed that the first time they noticed flames was shortly after the landing gear was lowered. The fire continued to burn throughout the flight, the landing rollout, and after the aircraft came to a stop against the jetway.

Approximately 7 minutes after the aircraft came to a stop the fire department radioed to the fire station dispatcher that the fire was completely extinguished.

## EVACUATION

There were 3 crew and 37 passengers aboard.

Within 15 seconds, after the aircraft came to a stop, the flight crew saw fire suppressant foam being applied to the aircraft. The captain attempted to open the cockpit door and the overhead emergency exits, both of which were jammed. The first officer then attempted to break the captain's side window with the fire axe, but he was not successful. They then heard the firefighters assisting the passengers and were told to wait until the injured passengers had been evacuated. Subsequently, the firefighters opened the jammed cockpit door and assisted the pilots off the aircraft.

All passengers escaped or were evacuated through the left mid-cabin window emergency exit or the hole in the right side of the fuselage.

A firefighter entered the cabin as soon as passengers stopped using the exit and began extricating two passengers (seated in 1E and 2E) who were trapped by wreckage. Other firefighters assisted with the extrication after the fire was extinguished and both passengers were removed from the wreckage on backboards. The first officer and the captain were the last two individuals to be assisted off the aircraft. At approximately 21 minutes after the crash, all occupants had been removed.

## AIRCRAFT FACTORS

The aircraft was a DHC-8-102 registered as N819PH operated by Horizon Air, Inc.

The aircraft was completed on 21-Dec-1985 as serial number 061 and acquired by Horizon Air on 6-Feb-1987.

The cabin was configured with 37 passenger coach seats. Seat rows 1-8 were double occupancy seats with an aisle down the middle and row 9 was a continuous row that seated 5 passengers. An aft facing single-occupancy flight attendant jumpseat was attached to the left rear side of the closet/wardrobe adjacent to the forward main cabin door.

The cockpit seating arrangement consisted of seats for the captain and first officer and a stowable jumpseat (stowed during this accident) on the front face of the cockpit door.

The fuselage was fitted with a main cabin door at the front on the port side with a forward cabin emergency exit door opposite. There was an emergency exit under each wing at seat row 4. The cockpit roof was fitted with an escape hatch.

#### ENVIRONMENTAL CONDITIONS

The accident occurred during the hours of daylight. Visibility was 7 miles, wind 250 deg at 4 knots and the ambient temperature was 16°C.

#### INJURIES TO OCCUPANTS

There were 3 crew and 37 passengers aboard. Four passengers suffered serious injuries. Three crew and 33 passengers received minor or no injuries.

During the accident sequence, 4 passengers received serious injuries; 24 passengers, the flight attendant, and both pilots received minor injuries; and 9 passengers received no injuries.

The passenger in seat 1E sustained a lacerated aorta.

#### **ACCIDENT SCENARIOS AND SURVIVABILITY CHAINS**

This accident is considered as having three scenarios, as shown in figure A-3.

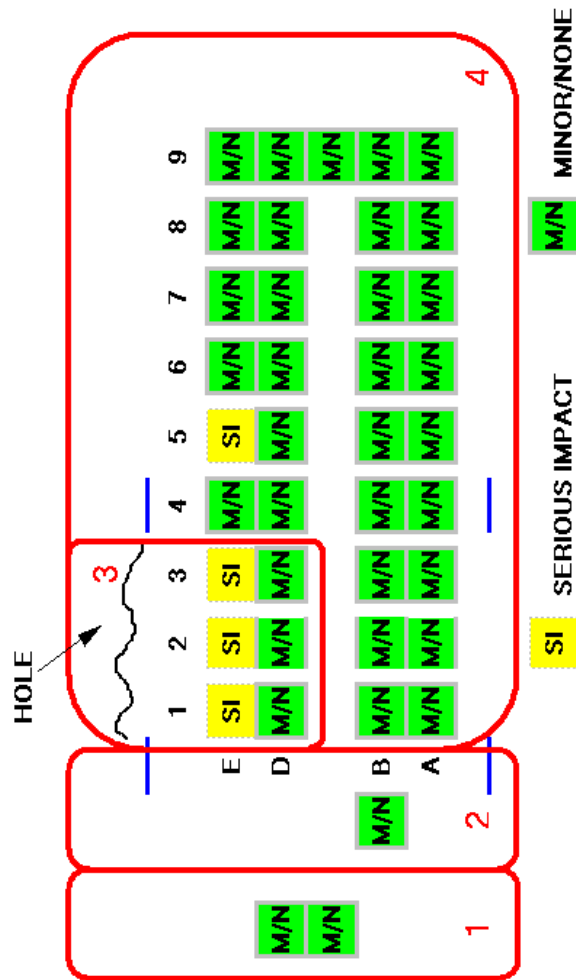
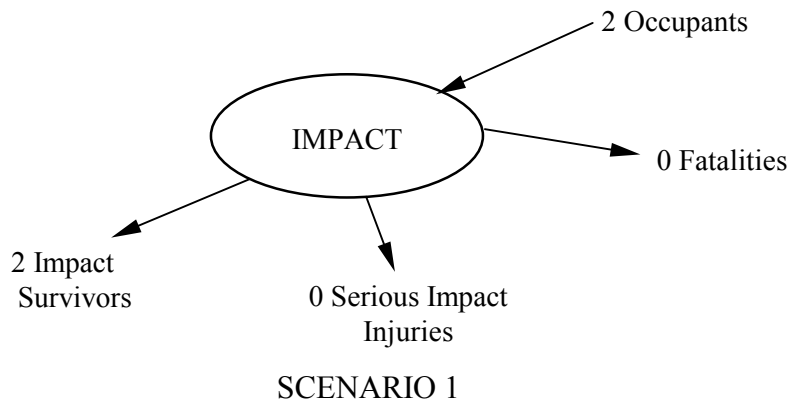
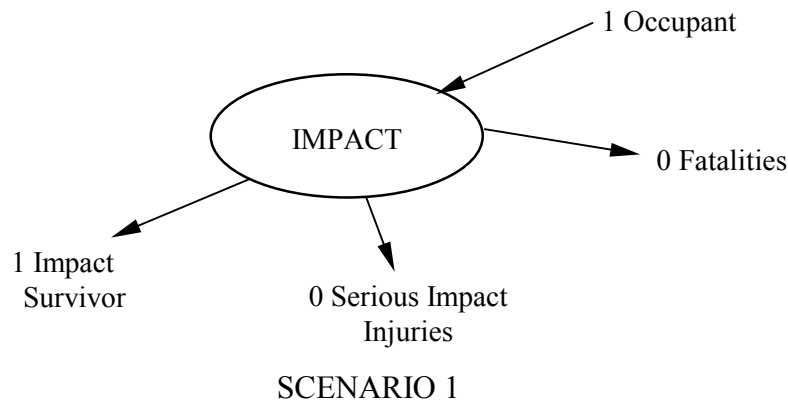

FIGURE A-3. LOCATION OF INJURIES AND SCENARIOS

**Scenario 1** represents the cockpit area where the two flight crewmembers were located. Both flight crewmembers sustained minor or no injuries.



**Scenario 2** represents the forward vestibule area occupied by a flight attendant who sustained minor or no injuries.



**Scenario 3** represents that portion of the passenger cabin containing seats 1DE, 2DE, and 3DE. This was reported to be the most heavily damaged area during impact with ground equipment. There were six occupants in this area, three sustained serious injuries, and three were uninjured. The survivability chain for this area is:

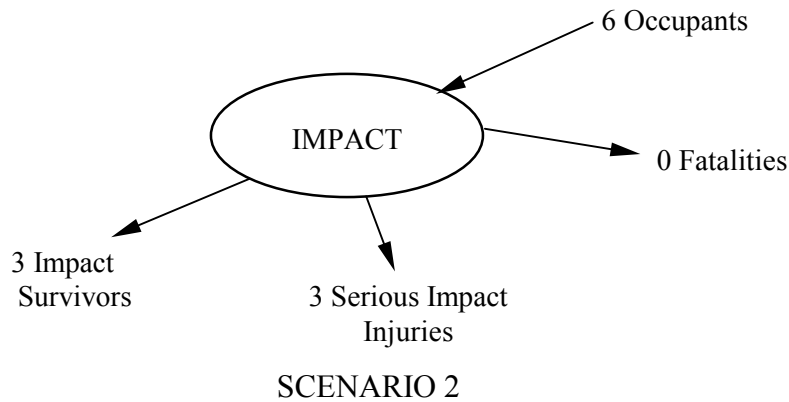

**Scenario 4** represents the remainder of the passenger cabin. There were thirty-one occupants in this area, one sustained serious injuries, and thirty were uninjured. The survivability chain for this area is:

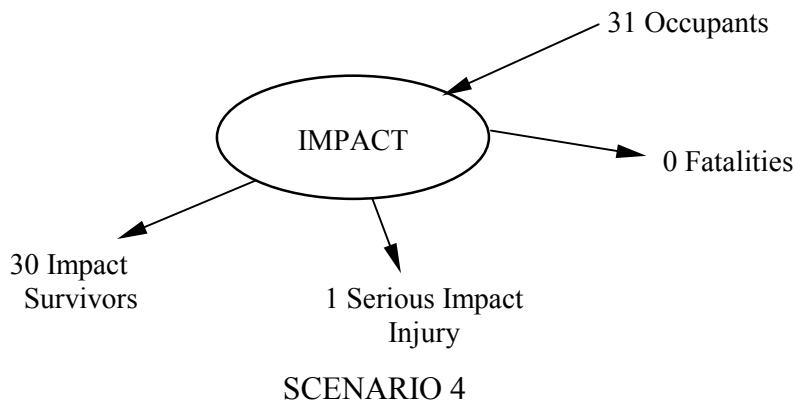

## **EFFECT OF INTRODUCING 16-g SEATS**

### **Scenario 1**

This scenario contains only flight crew seats and therefore benefit from the introduction of 16-g passenger seats is not applicable.

### **Scenario 2**

This scenario contains only the cabin crew seat and therefore benefit from the introduction of 16-g passenger seats is not applicable.

### **Scenario 3**

There were three seriously injured passengers in this scenario. The NTSB Accident Report states:

*“Seats 1DE, 2DE, and 3DE, in the area most heavily damaged during impact with ground equipment, were torn loose during the accident sequence. The passengers in seats 3D and 3E were ejected from the airplane while still buckled in their seats.”*

The seriously injured passengers in seats 1E and 2E had to be extricated from the wreckage and the passenger in seat 1E suffered a lacerated aorta. On this basis, even if they had sustained seat-related injuries, it is feasible that they also suffered serious injuries from the general disruption in the area.

The seriously injured passenger in seat 3E and the passenger in seat 3D were ejected from the aircraft whilst still in their seats. It is possible that the passenger in 3E may not have been seriously injured had the seat remained in the aircraft however this was not the case with the occupants of seats 1E and 2E.

It is possible that the three seriously injured passengers in this scenario would have only sustained minor injuries had their seats met the 16-g criteria. However, it is considered most likely that this would not be the case and that due to the degree of disruption they would have still been seriously injured.

The following summarises the overall assessment of the impact injuries that might result had the seats in this scenario been compliant with the 16-g criteria:

	<b>Minor or No Injuries</b>	<b>Serious Injuries</b>	<b>Fatal Injuries</b>
<b>High</b>	<b>3</b>	<b>3</b>	<b>0</b>
<b>Median</b>	<b>5</b>	<b>2</b>	<b>0</b>
<b>Low</b>	<b>6</b>	<b>0</b>	<b>0</b>

#### Scenario 4

There was only one seriously injured passenger in this scenario. The precise nature of the injuries is unknown. The accident report states: “*The forward and aft outboard leg attachments of seat 9E separated from the floor track. All other passenger seats (other than 1DE, 2DE, 3DE and 9E) as well as the flight attendant’s seat remained attached to the floor, although some passenger seats sustained some degree of impact deformation.*”

It is evident that the deceleration forces in this accident were high and had the seats met the HIC criteria appropriate to 16-g seats the passenger may not have sustained serious injuries.

The following summarises the overall assessment of the impact injuries that might result had the seats in this scenario been fully compliant with the 16-g criteria:

	<b>Minor or No Injuries</b>	<b>Serious Injuries</b>	<b>Fatal Injuries</b>
<b>High</b>	<b>30</b>	<b>1</b>	<b>0</b>
<b>Median</b>	<b>31</b>	<b>0</b>	<b>0</b>
<b>Low</b>	<b>31</b>	<b>0</b>	<b>0</b>

## ACCIDENT REF: 19880626B

Date:	26-Jun-1988	Flight Phase:	Go-Around
Aircraft:	A320	Location:	Habsheim

### DESCRIPTION OF ACCIDENT

#### RESUME

During an airshow on 26-Jun-1988, A320 F-GKFC made a level pass at about 30 ft, gear and flaps out, engines almost at idle, and 130 passengers on board. After the go-around, the aircraft hit trees at the end of the runway. The right wing broke up and a fire erupted.

All passengers evacuated the aircraft except three who suffered fatal injuries as a result of the fire.

#### IMPACT

The aircraft touched the trees shortly after the end of the runway at 12:45.40; at this time engine speed was around 83% NI, and the pitch attitude of the aircraft was 14 deg.

The first contact between the aircraft and the trees was made by the rear section of the fuselage, the tailplane, and then the engine nacelles and the main landing gear.

The aircraft sank slowly into the forest. The tip of the right wing then the right wing itself broke, finally the aircraft came to rest.

#### FIRE

As the right wing broke fuel was projected forward and fire immediately broke out and penetrated the cabin as soon as the aircraft came to rest. Fuel flowed under the cabin and as a result fire also raged around the left wing.

#### EVACUATION

There were 2 flight crew, 4 cabin crew, and 130 passengers on board.

As soon as the aircraft came to rest, the stewards stationed at the forward and aft doors, seeing the fire on the right of the aircraft, opened the left doors.

The normal lighting went off and the emergency lighting did not come on due to a design error in its automatic illumination program.

The captain declared that he made several attempts to trigger the evacuation signal; but it seems that this signal did not work, as nobody in the cabin heard it.



The purser wished to broadcast a message via the public address but could not find the handset, which apparently had been torn from its support, maybe due to the fragility of this support and of the attachment of the electrical lead.

A passenger stated that he had wanted to open the left wing emergency exit but could not reach it. The opening of this exit would have been very dangerous, as fire was raging around the left wing level.

The left forward door was blocked by branches after it had started to open correctly. The escape slide started to deploy partly outside and partly inside the cabin.

The purser, with the help of at least one passenger and an air hostess from another airline (who was in the cockpit as a passenger during the flight), pushed the door. The door opened suddenly and the purser and the passenger fell out of the aircraft and were covered by the escape slide.

The passengers started to panic and push in the front of the cabin. The passenger hostess then started to evacuate the passengers, but the first ones were blocked by branches in the escape slide. The other passengers jumped out beside the escape slide but they very quickly piled up on top of each other again due to the branches.

The hostess then stopped evacuation for a short while so that the passengers who had already jumped had time to extricate themselves. Meanwhile, on the outside, the purser, with the help of another air hostess, tore away the branches from across the escape slide to free the blocked passengers. After a certain time, the hostess herself left the aircraft suffering from the effects of the smoke.

The hostess stationed in the centre of the aircraft at 12D was pushed into the aisle by the passenger in 12F who was seriously burnt. The hostess was then carried forward while at the same time helping a passenger whose clothes were on fire.

She arrived at the left forward door (L1), no doubt after the evacuation of the previous hostess and she then took her place.

After the evacuation of the last persons to arrive at this door, she called into the cabin to find out if anyone was still there but did not get any reply; by this time, the very thick smoke and flames made any visual inspection impossible. On the order of the captain, who had just evacuated the injured first officer, she then left the aircraft.

The captain then returned to the cockpit to get an antismoke mask with the intention of going through the cabin, but in turn, had to leave before he could don the equipment, suffering from the effects of the fumes.

Note that the cabin attendants either were not able to use the antismoke masks during the evacuation or did not think of doing so. They were, in fact, more occupied in opening the doors as quickly as possible so as to speed up passenger evacuation.

The left aft door was opened without any problems and the escape slide was correctly deployed. The steward ordered the passengers to come toward him to evacuate and at the same time reassured them verbally. This, combined with the absence of smoke at the rear of the cabin, certainly contributed toward the good evacuation via this door.

After several passengers had used the escape slide, it was punctured on the branches. The steward asked his colleague to descend to help to receive the passengers. Evacuation continued without panic with the spontaneous help from one passenger, especially for the evacuation of an elderly person who had difficulty in moving.

After the last passengers had left the aircraft, the hostess returned to go through the cabin but the flames and smoke had reached the galley; she was able only to shout out in the direction of the cabin.

During the evacuation, the stewards and hostesses could not see what was happening at the other end of the aircraft due to the fire around the left wing. Therefore, after the end of evacuation via their door, they went round the wing toward the front or the rear to see if they could be of any help at the other door.

It has not been possible to determine the time it took to evacuate the survivors.

All passengers were able to leave the aircraft except three who succumbed to the fire.

#### AIRCRAFT FACTORS

The aircraft was an A320-100, registered as F-GFKC and operated by Air Charter International.

The aircraft obtained its Certificate of Airworthiness on 22-Jun-1988 and was delivered on 24-Jun-1988.

The aircraft was fitted with two doors at the front and two doors at the rear of the passenger cabin. In addition there were two overwing emergency exits over each wing.

#### ENVIRONMENTAL CONDITIONS

The accident happened in daylight during an airshow. Visibility was 8 km and wind was 010 deg at 6 kts.

#### INJURIES TO OCCUPANTS

All passengers were able to leave the aircraft except the three who succumbed to the fire:

- A young handicapped boy in seat 4F who seems to have remained in his seat.

- A little girl located at 5C who, according to her young brother (carried away by the flow of the other passengers), had not been able to open her seat belt and was blocked by the back of her seat, which was tilted over onto her.
- A woman travelling in seat 10B who, according to her husband, had reached the left forward door; as her body was found near that of the little girl, we can reasonably assume that she went back into the cabin to help the little girl and was overcome by the fumes.

### **EFFECT OF INTRODUCING 16-g SEATS**

It was stated in the accident report that all the occupants were able to leave the aircraft, except the three that succumbed to the fire.

The three occupants who died in the fire were a young handicapped boy in seat 4F, a little girl located at 5C, and a woman in seat 10B. The woman in seat 10B went back into the cabin to help the little girl and she was overcome by the fumes.

Therefore, it is assessed that the introduction of 16-g seats would not have provided any additional benefit in this accident.

## ACCIDENT REF: 19880831A

Date:	<b>31-Aug-1988</b>	Flight Phase:	<b>Landing</b>
Aircraft:	<b>Trident</b>	Location:	<b>Hong Kong</b>

### DESCRIPTION OF ACCIDENT

#### RESUME

On 31-Aug-1988 a CAAC Trident 2E registered as B-2218 was making an ILS approach to Hong Kong International Airport (HKIA) in heavy rain.

As the aircraft neared the runway the right outboard trailing edge wing flap struck the innermost approach light and the right main landing gear tyres hit the facing edge of the runway promontory. The right main gear was torn from the wing. The aircraft became airborne again and next contacted the ground 600 metres down the runway. It then veered off the runway to the right, yawed to the right and slid diagonally sideways across the grassed runway strip. The nosewheel and left main gear collapsed, and the aircraft continued until it crossed the parallel taxiway and slid sideways over the edge of the promontory into Kowloon Bay. The aircraft came to rest in the water with the rear extremity of the fuselage supported on a ledge of stone blocks that jutted out from the promontory. Part of the forward fuselage, including the flight compartment, was partially detached from the remainder of the fuselage and hung down at a steep angle into the water from control cables and secondary structure. A fire started in the centre engine intake duct.

The aircraft was carrying 78 passengers, 3 cabin attendants, 2 security officers, and a flight deck crew of 6. Six crew and 1 passenger suffered fatal injuries. Two crew and 2 passengers suffered serious injuries. Three crew and 75 passengers suffered minor or no injuries.

#### IMPACT

As the aircraft neared the runway the right outboard trailing edge wing flap struck the innermost approach light and the right main landing gear tyres hit the facing edge of the runway promontory. The right main gear was torn from the wing. The aircraft became airborne again and next contacted the ground 600 metres down the runway. It then veered off the runway to the right, yawed to the right and slid diagonally sideways across the grassed runway strip. The nosewheel and left main gear collapsed, and the aircraft continued until it crossed the parallel taxiway and slid sideways over the edge of the promontory into Kowloon Bay.

The aircraft came to rest in the water with the rear extremity of the fuselage supported on a ledge of stone blocks that jutted out from the promontory. Part of the forward fuselage, including the flight compartment, was partially detached from the remainder of the fuselage and hung down at a steep angle into the water from control cables and secondary structure. A diver reported that

the extremity of the nose rested in contact with the sea bed approximately 12 feet below the surface.

There was a strong current flowing in Kowloon Bay and this caused the wreck to rotate slowly clockwise. As it turned, the right wing remained above the water and provided a convenient platform for the passengers who exited the aircraft via the right hand overwing exit. Eventually the right wing tip contacted, and lodged upon, the ledge of stones at the base of the promontory. Passengers reported that the rear of the passenger cabin was under water to a depth of approximately 3 feet.

Deceleration forces were not high and minimal structural distortion was caused to the rear passenger cabin where 70 of the 89 persons on board were seated.

Examination of the passenger seats showed none to have failed structurally as a result of the impact forces, although several units from the front cabin were distorted as a result of the fuselage failure. No seat belts had failed.

#### FIRE

The duty officer had watched the aircraft pass by in an unusual attitude on the runway and pressed the crash alarm. As a result it took less than 1 minute for the rescue services to arrive on the scene.

At the rear of the aircraft the centre engine detached from the airframe and a fire started in the centre engine intake duct. A thin layer of fuel spread over the surrounding water.

The fire in the centre engine intake duct was soon extinguished by a fireman climbing onto the fuselage with a handline and spraying water into the intake. Meanwhile foam was sprayed over the fuel floating on the surrounding water and the wreck secured by lines to the shore.

#### EVACUATION

There were 6 flight crew, 5 cabin crew, and 78 passengers aboard.

There were no passenger safety briefing cards on the aircraft.

Passengers reported that the cabin attendants did not make a safety briefing and that the methods of fixing and releasing seat belts were not demonstrated. Neither were the locations and method of use of the emergency exits pointed out to them.

Seventy-six passengers escaped from the aircraft through the forward right overwing emergency exit and the midships passenger door. Some stood on the wing in the heavy rain and waited to be rescued. Others jumped into the water and a few were able to scramble ashore.

When the rescue personnel boarded the aircraft to check whether it was clear of survivors they found two passengers (in seat row 4) trapped in the left side of the forward cabin at the point where the fuselage had buckled. One, who appeared to have a broken arm, was entangled with seat wreckage and collapsed cabin furnishings. The other, similarly ensnared, had only his head above water. Both were quickly released and removed from the aircraft. One later died in the hospital.

Of the three cabin attendants, two were seated in cabin crew seats at the midship passenger door and one in the forward passenger cabin in a passenger seat in row 2. The two security officers were seated in row 1.

The two security officers and one cabin attendant were seated in the first 2 rows of the front passenger cabin and were cut off from the rest of the passenger compartment by the break in the fuselage. They were unable to help in the evacuation and left the wreck through a break in the side of the fuselage.

The remaining two cabin attendants were seated at the midships passenger door. One had not fastened her seat belt for landing and was rendered unconscious. She regained consciousness in the water and while clinging to some wreckage was rescued by emergency services personnel. It is presumed that she exited the aircraft through the midship door, but she had no recollection of having done so. The other cabin attendant opened the midships passenger door and directed the evacuation of the passengers. After checking that the passenger cabin was clear she left the aircraft. Some passengers jumped from this exit into the water and swam ashore and five were rescued by a passing junk. Approximately 10 passengers in total used this escape route.

The flight compartment and front portion of the passenger cabin hung down into the water at a steep angle with the nose resting on the sea bed. The six flight deck crew were trapped in the submerged flight compartment and all drowned. Attempts were made by divers to enter the submerged flight deck but these were hampered by the very poor visibility in the polluted water, the strong current, and by wreckage blocking the entrance to the flight deck.

The passenger in seat 4B, where the fuselage buckled inwards, suffered fatal injuries and died in hospital. It was not possible to determine whether he had been strapped in, but as the seat belt was intact and he was found forward and out of his seat by the rescue personnel, it seems likely that he may not have been. The autopsy showed that he suffered numerous fractures of bones on the left side of his body and these were probably caused by the fuselage structure that protruded into the cabin.

Passenger entry doors on this aircraft were of the inward opening plug type with an “up and over” action, stowing into the roof. After the accident both the front and midship passenger doors were found open, with the midship door undamaged and in the stowed position. The front passenger door was missing and had not been recovered. It is believed to have been lost during the transit of the sea wall when the forward fuselage suffered considerable distortion. The front emergency exit door was found secured closed and could not be operated; however, this was not surprising as this part of the fuselage had suffered major damage and distortion.

The forward right escape hatch and the rear left hatch were found open. During the ground slide, the forward right overwing exit partially opened. When the aircraft came to a halt a passenger, seeing daylight through the gap and thinking it to be a hole in the fuselage, kicked at it to enlarge it and the hatch sprang open. This exit had a relatively clear path to it from the aisle and those passengers that did not use the midship door escaped through it onto the right wing.

The rear left escape hatch also sprang open during the ground slide and lodged itself against an adjacent seat back. No attempt was made by the passengers to further open this hatch and it was not used as an escape route.

The other two escape hatches were found closed but operated without difficulty several days later during examination of the wreckage.

Examination of the passenger cabins failed to reveal any passenger lifejackets. Two lifejackets were found on board (both with live inflation bottles), one in a cupboard close to the centre galley, the other in the flight compartment. The seat back in front of each passenger carried a placard saying that there was a lifejacket under each seat.

#### AIRCRAFT FACTORS

The aircraft was a Trident 2E registered as B-2218 and operated by the Civil Aviation Administration of China (CAAC).

The aircraft was manufactured in 1973.

The flight compartment on this aircraft was fitted with five crew stations for two pilots, a flight engineer, a radio operator and a navigator. All stations were fitted with a standard crew seat equipped with an inertia reel shoulder harness and lap straps with a quick release buckle. The shoulder harness on all five seats was covered over by a loose seat cover fitted to each seat and was therefore not readily available for use. On some seats the shoulder harness straps had been tied together under the seat pan. The lack of wear on the lugs at the end of each shoulder harness strap, compared with that on the lap strap, showed that the shoulder harnesses had been used only a few times since they were installed.

The aircraft was not designed or equipped to accommodate more than five flight deck crew. Nevertheless, a sixth flight crewmember, a radio operator under training, was carried and accommodated in the flight compartment throughout the flight (including the takeoff and landing) on a loose metal stool. No provision was made to restrain either the stool or the crewmember using it.

The entrance door to the flight compartment was hinged so that it opened into the flight deck. The original door was constructed from frangible material to permit its use as an emergency exit but on this aircraft was replaced by a heavy armour-plated door.

The aircraft had two passenger entry doors on the left side of the fuselage forward of the wing, referred to as the front and midship passenger doors. Located opposite the front passenger entry door was a smaller service door, referred to as the front emergency exit door. Opposite the midship passenger door there was a galley area.

Passenger entry doors on this aircraft were of the inward opening plug type with an “up and over” action, stowing into the roof.

There were two inward opening escape hatches on each side of the aircraft, located over the wings, at seat rows 10 and 11. Seat row pitching in this cabin was such that none of these hatches had a clear path to them from the aisle.

The passenger cabin was configured with a total of 106 passenger seats. The configuration divided the passenger compartment into two with 6 seat rows forward of the midship passenger door/galley area and 12 behind it. With the exception of the last row the seat units were all of the triple type allowing for six abreast seating about a central aisle. Because of the narrowing of the fuselage the last row (18) was only four abreast.

Stowage in the passenger cabins for hand baggage was provided by overhead open shelving (hatracks). Forty-eight pieces of hand baggage were recovered from both passenger cabins.

#### ENVIRONMENTAL CONDITIONS

The accident occurred during daylight hours in heavy rain.

Wind was between 090 deg and 140 deg at 10 kts. Visibility was 5 km.

It rained heavily and continuously throughout the rescue phase.

#### INJURIES TO OCCUPANTS

The aircraft was carrying 78 passengers, 3 cabin attendants, 3 security officers, and a flight deck crew of 6. Six crew and one passenger suffered fatal injuries. Two crew and two passengers suffered serious injuries. Three crew and 75 passengers suffered minor or no injuries.

Pathological examination of the bodies of the flight crewmembers revealed injuries which were consistent with having been involved in an aircraft accident; however, the cause of death in each case was found to be drowning. No evidence was found of any pre-existing medical condition which could have contributed to the accident.

Passenger injuries were mainly minor and the injured passengers were seated either in the forward cabin or on the right side in the rear cabin. No passengers seated on the left side of the rear cabin were hurt. Some passengers admitted to not having their seat belts fastened and one cabin attendant did not fasten her belt.



The passenger in seat 4B, where the fuselage buckled inwards, suffered fatal injuries and died in hospital. It was not possible to determine whether he had been strapped in, but as the seat belt was intact and he was found forward and out of his seat by the rescue personnel, it seems likely that he may not have been. The autopsy showed that he suffered numerous fractures of bones on the left side of his body and these were probably caused by the fuselage structure that protruded into the cabin.

### **EFFECT OF INTRODUCING 16-g SEATS**

The accident report states that the deceleration forces were not high and there were no seats detachment or seats failures as a result of the impact. There were no serious head injuries reported.

The accident report also states:

*“When the rescue personnel boarded the aircraft to check whether it was clear of survivors they found 2 passengers (in seat row 4) trapped in the left side of the forward cabin at the point where the fuselage had buckled. One, who appeared to have a broken arm, was entangled with seat wreckage and collapsed cabin furnishings. The other, similarly ensnared, had only his head above water. Both were quickly released and removed from the aircraft. One later died in hospital.”*

Since the deceleration forces were low, there were no seat failures; no reported head injuries to the passengers; and it is known that

- one of the seriously injured passengers appeared to have a broken arm and was located close to where the fuselage structure protruded into the cabin, and
- the fatally injured passenger was suspected not to have had his seat belt fastened and that he sustained injuries that were probably caused by the fuselage structure that protruded into the cabin.

It is considered that 16-g seats would have had no influence on the passenger injuries sustained in this accident.

## ACCIDENT REF: 19880831B

Date:	<b>31-Aug-1988</b>	Flight Phase:	<b>Takeoff</b>
Aircraft:	<b>B727</b>	Location:	<b>Dallas</b>

### DESCRIPTION OF ACCIDENT

#### RESUME

On 31-Aug-1988, B727-232 registered as N473DA was taking off from Dallas-Fort Worth International Airport, Texas. The slats and flaps were not properly configured and as a result the aircraft did not gain altitude after rotation.

The aeroplane struck an instrument landing system (ILS) localiser antenna array approximately 1000 feet beyond the end of the runway and came to rest about 3200 feet beyond the departure end of the runway. The flight was airborne approximately 22 seconds from lift-off to the first ground impact near the ILS localiser antenna. The aeroplane was destroyed by impact forces and the postcrash fire.

The combination of jammed left aft service door and the intense impenetrable fire trapped 12 occupants.

Of the 108 occupants aboard, 12 passengers and 2 crewmembers were killed by fire, 21 passengers and 5 crewmembers were seriously injured, and 68 passengers sustained minor or no injuries.

#### IMPACT

The aeroplane struck the instrument landing system (ILS) localiser antenna array approximately 1000 feet beyond the end of runway 18L and came to rest about 3200 feet beyond the departure end of the runway. The flight was airborne approximately 22 seconds from lift-off to the first ground impact near the ILS localiser antenna.

The fuselage had separated into three major sections: (1) the forward section consisted of the nose forward of fuselage station (FS)-420 (just aft of seat row 1); (2) the centre fuselage section included the body structure between FS-420 and FS-950c (between seat rows 27 and 28); and (3) the aft fuselage section extended from FS-950c aft to the end of the No. 2 engine tailpipe.

The forward fuselage section had rotated to the left about 45 deg. The entire lower fuselage structure sustained various degrees of tearing, buckling, and general overall distortion. Some sooting was noted in the area between the first officer's side window and the separation.

The centre fuselage section came to rest right side up and was supported by the left wing and right wing centre section.

## FIRE

The external fire was initiated when the right wing and tail struck the localiser antenna array. The fire intensified when the aircraft struck the lip of a depression in the terrain. Flames not only impinged on the right side of the fuselage but extended around the fuselage, heating the inboard wing area on the left side. The forward door of the aft cargo compartment was torn off at its hinges, causing a large opening in that area through which fire entered the cargo area before the aircraft came to rest. The fire burned through the floor.

Fire also entered the cabin through the aft break in the fuselage and later through a burnthrough in the centre wing box area.

The left side forward of FS-720e (between seat rows 17 and 18) showed no evidence of fire damage and all passenger windows were intact. However, the left side between FS-720e and FS-950c had sustained varying degrees of fire damage. In the general area of FS-950c, some fuselage structure had been consumed by fire.

The right side of the centre fuselage section between FS-420 and FS-950c also contained fire damage with some fuselage areas totally consumed by fire. All passenger windows on the right side were missing or melted.

The fuselage crown between FS-450 (between seat rows 2 and 3) and FS-680 (between seat rows 13 and 14) from the top of the passenger window line on the right side to the top of the Delta logo on the left side was consumed by fire. Another area of the top fuselage, between FS-720c (between seat rows 16 and 17) and FS-840 (between seat rows 21 and 22), was consumed by fire from the top of the right forward overwing emergency exit door to the fuselage centreline.

The aft fuselage section had rolled to the left and rotated counter clockwise about 45 deg. The aft fuselage skin structure between FS-950c and FS-950e (between seat rows 28 and 29) on the left side was consumed by fire. The aft fuselage skin structure on the right side between FS-950e and FS-1030 (between seat rows 31 and 32) was found laying on the ground alongside the fuselage.

The centre aft fuselage section generally sustained various degrees of breakup and fire damage.

The aft cabin floor was completely consumed by fire from approximately station 950d (seat row 28) to station 1130 (just aft of seat row 36) with the exception of the passageway that led to the left-rear door at the galley. Fire damage to other components was also extensive in this area with most major interior components destroyed.

The area forward of station 950d had less severe fire damage to the floor and sidewall areas (continuing through station 740 between seat rows 18 and 19). As noted previously, there was a large area of burnthrough on the cabin floor from approximately station 740 to approximately station 720d (seat row 17) on the right side. From this point forward to approximately station 400 (just forward of seat row 1), fire damage to the right side of the interior was significantly

more extensive than that of the left side. From station 400 forward, the cabin was free of fire damage.

Damage to ceilings, sidewalls, overhead stowage compartments, closets, etc., was closely correlated to areas of floor and fuselage burnthrough. From station 400 aft, no ceiling panels were in place including areas where the fuselage crown was present as well as the areas that were burned through.

All floor exit level door liners were found. The aft right exit had only the lower portion of the liner present from approximately the top of the escape slide container downward. It was heavily sooted and showed some signs of melting. The aft left door liner was essentially intact with heavy charring and melting over the upper third of the surface. Both of the left and right forward door liners were free of fire damage. The liner on the ventral door was destroyed by fire.

Sidewalls were intact on the left side of the forward cabin from station 380 (forward edge of starboard service door) to the area of the overwing exit. Many of these panels were melted at the upper portion above the window, but were in place and otherwise intact. Sidewall panels on the right side of the cabin in this zone were completely destroyed. Small portions of other right side wall panels were present near the floor toward the aft part of the cabin. Two sidewall panels on the left side at approximately stations 950b and c (immediately forward of the separation in the aft fuselage) were relatively free of fire damage but were heavily sooted.

From station 380 to station 760 (between seat rows 19 and 20) on the left side, there were some large remnants of overhead stowage units hanging from the structure. These were extensively burned and melted; however, they were recognizable as overhead stowage units. No other overhead stowage units were present.

In most areas of the cabin wherever the sidewall and/or ceiling panels were destroyed, the thermal insulation was also destroyed. The following exceptions were noted:

- In the aft right corner of the cabin in the sidewall area just forward of and adjacent to the last row of seats.
- Some small areas over the overhead stowage bin area along the left side of the cabin between station 380 and 950.
- A few sidewall areas on the right side of the cabin near station 720.

The last row triple seats (right side) showed frame burnthrough and residual cushion fire-blocking layer. Up to and including row 28, all seats were missing with the exception of the triple seat in row 30 left side which had some cushion fire-blocking layer remaining along with some seat frame structure burnthrough on the seat back cushions. Rows 23 through 26 (right side) were heavily fire damaged, but some cushion fire-blocking layer remained. The seat back cushions on 23E, 24E, and 26D were burned through. Seats 27D, E, and F were severely damaged and its common frame was twisted and displaced several feet rearward from the proper

position. Rows 26 and 27 (left side) had fire-blocking layer present (frame intact), with the exception of seat back 26C which was totally destroyed by fire. Row 25 (left side) was missing (possibly falling down into the hole of the floor area). Rows 23 and 24 (left side) had fire-blocking layer remaining, except for row 24A, B, and C in which the seat back frame were totally destroyed by fire. Seats 22B and C sustained severe damage to the seat bottoms. The remaining seats in rows 20 through 22 (left side) sustained fire damage to the seat backs, burning through the seat back frame, but the seat bottom cushions in this area had some fire-blocking remaining. Rows 20 through 22 (right side) sustained fire damage to the seat back frame with some fire-blocking layer remaining except for row 20 which was pitched forward and bent up on the frame bottom.

Rows 15 through 19 (right side) sustained severe fire damage with no fire-blocking layer remaining. Rows 10 through 14 (right side) were destroyed by fire. Rows 10 through 19 (left side) had some fire-blocking layer remaining on the seat back and bottom cushions with the exception of rows 15 and 17 which sustained lesser amounts of fire damage.

In the first class section, seat row 1 (left and right sides) was intact with little fire damage. Row 2 (left side) had some fire damage to the seat back and bottom cushions with some fire-blocking layer remaining. Seats 3A and B were twisted with some fire damage. Seats 4A and B were fire damaged with some cushion fire-blocking layer remaining on the seat bottom. Row 3 (right side) was totally destroyed by fire. Row 4 (right side) was missing.

A number of lives were saved by the use of the fire-blocking layer on the passenger seats. An exact number of additional survivors could not be determined.

The fire services arrived within 5 minutes of notification. The fire was knocked down within 5 minutes and extinguished in about 40 minutes.

#### EVACUATION

There were 3 flight crew, 4 cabin crew, and 101 passengers aboard.

The investigation found that although the fuselage had separated in several places, the occupiable volume of the cabin was not substantially compromised. Passengers generally stated that impact forces were not severe. Further, the causes of death of the passengers in the aft section of the cabin were attributed to smoke inhalation and fire rather than impact injuries. Exit from the aft cabin was hampered by the fire that impinged on the right side of the aeroplane. Exit from the mid and forward cabin was through breaks in the fuselage and through the left side exits, except for the left aft service door which was not opened.

The right forward exit door was lodged in the wreckage. The main entry door (left forward) was open and wedged under the forward fuselage section.

Both overwing exit hatches on the left side were open. The hatch from the forward exit was found inside the cabin and the hatch from the rear exit was found outside the aircraft.

The right side rear overwing exit hatch was not opened; the hatch from the forward right side was found in the cabin.

The rear floor level exit on the right hand side was found not opened.

The left aft service door could not be opened due to deformation of the door frame which resulted from the aeroplane's repeated impacts with the ground.

A flight attendant, while attempting to open the left aft service door, stowed the girt bar on the door as per Delta's flight attendant training procedures which address the difficulty in opening a door following a gear-up landing.

It would have been unlikely for any one person of average strength to open the left aft service door under the circumstances existing at the time of the attempted evacuation.

The aft airstair was not usable because the aircraft was resting on its fuselage and the airstairs could not be lowered. Also the rear pressure bulkhead door to the tail cone was jammed closed due to impact damage.

#### AIRCRAFT FACTORS

The B727-232 was configured for a 3-person flight crew and 149 passengers. The passenger cabin was configured with 12 first-class passenger seats and 137 tourist-class seats. A double occupancy aft facing flight attendant seat was on the aft left side of the cockpit rear bulkhead; a double occupancy forward facing flight attendant seat was located on the central airstairs door. A single flight attendant seat was in row 32.

The aircraft was delivered to Delta Air Lines in November 1973 in a passenger configuration. It was serial number 20750, line number 992. Fire-blocking layers were fitted to passenger seats. This was the first survivable accident following the implementation of floor proximity lighting and fire-blocking rules. It can therefore be assumed that floor proximity lighting was also fitted.

The aircraft had a total of four floor level exits and four overwing emergency exits and a ventral stairway exit.

#### ENVIRONMENTAL CONDITIONS

The weather conditions at the time of the accident were visibility 10 miles, wind 100 deg at 8 knots, and temperature 22°C.

#### INJURIES TO OCCUPANTS

Of the 108 persons on board, 12 passengers and 2 crewmembers were killed, 21 passengers and 5 crewmembers were seriously injured, and 68 passengers sustained minor or no injuries.

The cause of death of the 11 passengers and the 2 flight attendants was determined to be smoke inhalation. Levels of carboxyhemoglobin (COHb) ranged from 15 to 81 percent. Tests for drugs and ethanol were negative in all 13 persons. A 14th fatality was a passenger who had successfully evacuated but later attempted to re-enter the burning aeroplane. This passenger died of severe burns 11 days after the accident.

### **EFFECT OF INTRODUCING 16-g SEATS**

Survivors generally stated that impact forces were not severe. Although some seats were damaged during the impact sequence, the cause of death for those fatally injured passengers was smoke inhalation and burns. Since there are no reports of the passenger fatalities sustaining impact injuries, it is likely that the serious injuries were due to the fire only. It is therefore assessed that the introduction of 16-g seats would have provided no benefit in this accident.

## ACCIDENT REF: 19890108A

Date:	<b>08-Jan-1989</b>	Flight Phase:	<b>Climb</b>
Aircraft:	<b>B737</b>	Location:	<b>Kegworth</b>

### DESCRIPTION OF ACCIDENT

#### RESUME

G-OBME left Heathrow Airport for Belfast at 1952 hrs with 8 crew and 118 passengers (including 1 infant) on board. As the aircraft was climbing through 28,300 feet, the outer panel of one blade in the fan of the No. 1 (left) engine detached. This gave rise to a series of compressor stalls in the No. 1 engine, which resulted in airframe shuddering, ingress of smoke and fumes to the flight deck, and fluctuations of the No. 1 engine parameters. Believing that the No. 2 engine had suffered damage, the crew throttled that engine back and subsequently shut it down. The shuddering caused by the surging of the No. 1 engine ceased as soon as the No. 2 engine was throttled back, which persuaded the crew that they had dealt correctly with the emergency. They then shut down the No. 2 engine. The No. 1 engine operated apparently normally after the initial period of severe vibration and during the subsequent descent.

The crew initiated a diversion to East Midlands Airport and received radar direction from air traffic control to position the aircraft for an instrument approach to land on runway 27. The approach continued normally, although with a high level of vibration from the No. 1 engine until an abrupt reduction of power followed by a fire warning occurred on this engine at a point 2.4 nm from the runway. Efforts to restart the No. 2 engine were not successful.

The aircraft initially struck a field adjacent to the eastern embankment of the M1 motorway and then suffered a second severe impact on the sloping western embankment of the motorway.

Thirty-nine passengers died in the accident and a further eight passengers died later from their injuries. Of the other 79 occupants, 74 suffered serious injury.

#### IMPACT

During the descent, the cabin crew carried out their emergency drills, checking that all passengers had their lap belts fastened and stowing all loose carry-on luggage in the overhead bins. Approximately 10 seconds prior to the first impact the commander warned the passengers to prepare for a crash landing. Some, but not all, of the passengers adopted a crash position prior to the aircraft striking the ground.

The aircraft suffered two distinct impacts with the ground, the first just before the eastern embankment of the M1 motorway and the second on the western edge of the northbound M1 carriageway at the base of the western embankment. The first impact was at an airspeed of 113 knots CAS, with a rate of descent of between 8.5 feet/sec and 16 feet/sec. The pitch attitude was



13° nose up. The second and major impact occurred at a speed of between 80 and 100 knots, at an angle of approximately 16° below the horizontal, and with the aircraft at a pitch attitude of between 9° and 14° nose down. The associated peak deceleration was of the order of 22 to 28 g, predominantly longitudinal.

In the second impact, the forward fuselage separated from the overwing section of fuselage and the tail section buckled over and to the right of that section of fuselage just aft of the wing.

Two major structural failures of the fuselage occurred in the impact, one slightly forward of the wing leading edge (approximately stations 500B to 500D) and one aft of the trailing edge (approximately stations 727G to 827). These failures left the structure in three principal sections. In addition, all three landing gear legs and both engine supports failed without rupturing the fuel tanks.

A total of 21 of the 52 triple seats remained fully attached to the cabin floor: 14 of these were in the overwing area and 7 in the aft fuselage.

During the impact the fuselage broke into three main sections with four distinct areas of damage: the area forward of the wing (rows 1-9) where the floor structure was completely disrupted and all the seats became detached; the centre section (rows 10-17) where the majority of the seats remained attached to the floor; and the area behind the wing (rows 18-23L/24R) where the floor failed and the fuselage was disrupted, both circumferentially and from above, by the overturning tail section in which seat rows 24L/25R-27 remained attached.

All five attendant seats had been occupied at ground impact. The aft attendant seats (one double seat, one single) remained intact, with some downwards distortion of the seat pan of the aft double seat. However, the aft/left toilet module, to which this double seat was attached, had partially separated from the airframe. This had allowed the toilet aft bulkhead, with this double seat, to rotate through approximately 90° into the centre aisle.

All the overhead stowage bins were recovered from the wreckage and their respective cabin positions determined. Photographs taken during the rescue operation on the night of the accident did not show any of the bins in the forward and centre sections still to be attached at their fuselage attachments apart from the forward bin on the right-hand side (1R), which was partially detached. Interview evidence with rescuers indicated that this had been caused by the aircraft impact and not by rescue personnel. The bins in the remaining sections (areas III and IV) were also found detached and although there was no photographic evidence to show when this had occurred, the evidence from the rescuers again indicated that these detachments had been caused by the impact.

Some of the doors on the overhead stowage bins opened during the last seconds of flight. There was no evidence to show whether or not either the bins or their contents had been in forcible contact with any of the aircraft occupants.

The initial injuries that occurred were caused by the impact of a seat occupant into the back of the seat in front. In those areas where the floor structure, and hence the seat attachment, failed, the initial injury mechanism was compounded by secondary impacts of the seat occupant with loose seats and passengers and other parts of damaged aircraft structure.

Virtually all the passengers sitting in seat rows 10-17 and 25-27 suffered from severe bruising under the lap belt and five passengers sustained iliac fractures as a direct result of lap belt loading.

In addition to the results of direct loading of the pelvis by the lap belt the following generalised injury mechanism occurred. As the seat occupant moved forward, the knees contacted the back of the seat in front, loading the knee and the upper leg. This transmitted load back into the pelvis causing a variety of injuries including dislocation of the hip, fracture of the hip joint, and fracture of the pelvis. Fractures of the femur occurred as a result of the combination of axial and bending loads induced by the front cross bar of the seat as well as contact with the back of the seat in front. Depending upon the position of the lower leg, damage was caused to the knee as the upper leg moved forwards in relation to the lower leg. In a similar manner, where the foot was fixed by contact with aircraft or seat structure, the foot and ankle also sustained injury as the lower leg moved forward in relation to the foot and ankle, causing a combination of torsional and posterior dislocation injuries.

Gross lower leg fractures occurred where the seats failed and the lower legs were trapped and subjected to secondary impacts.

Head and chest injury occurred even where passengers had adopted the crash position and some passengers who rested their heads on their forearms prior to the impact fractured their forearms as a consequence. Some other passengers braced themselves by placing their extended arms onto the back of the seat in front, and some of them suffered fractured upper arms and shoulder joints in consequence.

The child seated on his mother's lap in seat 3F sustained major head and limb injuries as a result of the accident and the mother sustained major injuries, some of which were suggestive of having been caused by forcible flexion of the mother over the child during the impact.

## FIRE

There were two separate areas on the No. 1 engine which had been affected by fire and these were the only areas where there was evidence of fire on the aircraft. The most seriously affected zone was on the fan case within the forward engine cowling, and the less serious zone was on the rear edge of the reverser duct, on the outboard side.

Ground witness reports indicated that immediately after the ground impact of the aircraft the only fire visible was relatively localised and centred around the forward end of the No 1 engine, but that after a short time the fire suddenly grew in intensity. Upon the arrival of the airport fire

service, the fire was quickly extinguished using a combination of aqueous film forming foam (AFFF) and fluoroprotein foams.

#### EVACUATION

Due to the extent of the injuries to occupants, an evacuation under the direction of the cabin crew was not carried out. Only 14 of the passengers were able to make a significant contribution to effecting their own escape.

#### AIRCRAFT FACTORS

The aircraft was a Boeing 737 Series 400 with four floor level exits and four overwing exits. It was configured with 156 passenger seats in a single class cabin with a total of 26 rows of pairs of triple seats. The seats were of a type designated as the Model 4001 tourist seat by the manufacturer, Weber Aircraft, Inc. The seat rows were numbered conventionally from 1 to 27 (no row 13) from the front to the back of the aircraft. The seat pitch ranged from a maximum of 38 inches, for the two-seat rows (12 and 14) next to the overwing emergency exits to a minimum of 30 inches for row 27L. The remaining seat pitches were either 31 or 32 inches.

The upholstered seat backs are pivoted at the lower end to breakover forward to ease emergency evacuation and to recline for passenger comfort. The exceptions in the G-OBME configuration were the seats adjacent to the overwing exits, rows 11, 12, and 14, where the seat backs were fixed. The detachable flotation cushions are supported on an alloy sheet suspended between the front and rear horizontal spars: these spars are mounted on a welded lower structure of hollow steel members of square section. Longitudinal locking to the seat tracks is at the rear attachments only and both the front and rear leg attachments are designed to allow for some angular deformation of the seat tracks in an impact. At the rear leg this flexibility is achieved by incorporating a pivot and at the forward leg a U-strap at the track attachment. The intent of the U-strap is principally to make the seat structure compliant with floor deformations and also to provide some load attenuation through the buckling mechanism.

The Model 4001 seats were approved by the FAA in December 1985 as meeting the performance standards of TSO-C39a and were approved by the CAA in February 1986 as meeting the more stringent requirements of BCAR Sections D3-8 and D4-4.

In addition to meeting the static loading criteria required by the above performance standards, the Model 4001 seat was tested at the FAA's Civil Aeromedical Institute (CAMI) in 1987 to the standards of FAR Part 25 Amendment 25-64, (paragraph 1.17.11). Although these Amendment 25-64 (dynamic loading criteria) tests were for development rather than certification, the results indicated that the seat would probably meet the certification criteria; although the testing was done prior to the issue of the requirements for seat deformation. Longitudinal impact tests on the front legs had shown buckling loads of around 4800 lb. for the U-strap at the base of the front leg; load cell measurements on the test leg showed, for the 16-g/44-feet-per-second (fps) decelerations, vertical loads in excess of this (4800 lb.) load.

## ENVIRONMENTAL CONDITIONS

The actual weather at East Midlands Airport, reported to the pilot by ATC at 2011 hrs was wind velocity 250°/10 kts; visibility 10 km; cloud 7 oktas, base 1,700 feet; temperature +9°C; QNH 1018.

## INJURIES TO OCCUPANTS

There were 8 crew and 118 passengers ( including one infant) on board. Thirty-nine passengers died at the scene of the accident, 8 more died in hospital at times up to 22 days later. Of the other 79 occupants, 74 suffered serious injury.

The most severe injuries occurred in rows 6-8 in the region of the forward fuselage break, with serious injuries occurring in the whole of the area forward of the wing where the floor structure failed. Further serious and fatal injuries occurred in the region of the failure of the rear fuselage and floor and in the area where the tail structure had swung over, and into, the rear fuselage. The least injuries occurred in the rear of the aircraft.

All but 1 of the 39 fatalities at the scene of the accident sustained head injuries of varying severity. Forty-three nonsurvivors had facial injuries. Seventy-four of the 83 patients removed to the hospital had suffered head or facial injury. Thirty-one cases of facial injury required treatment. Seventeen patients showed clinical evidence of a strike to the head from behind. Forty-three of the patients at the hospital had suffered an episode of impairment of consciousness. Five of the 83 patients removed to the hospital had suffered severe head injuries.

Twenty-one nonsurvivors and 6 survivors sustained injuries to neck structure.

Nineteen fatalities and 28 survivors sustained fractures and dislocations of the upper limbs and shoulders.

Some degree of generally major chest injury was found in all but one of the fatalities. Eighteen of the 79 survivors also suffered major chest trauma.

Thirty-six fatalities suffered abdominal trauma compared to only two of the survivors who suffered a major abdominal injury.

Twenty-two survivors and 13 nonsurvivors sustained pelvic injuries. A considerable number of lower limb injuries also occurred. Twenty-two survivors and 13 nonsurvivors sustained fractured femurs, 18 survivors and 5 nonsurvivors sustained knee injuries, 31 survivors and 38 nonsurvivors sustained lower leg fractures, 26 survivors and 24 nonsurvivors sustained fractures/dislocations of the ankle, and 22 survivors and 6 nonsurvivors sustained fractures of the bones of the feet. Many of those affected suffered fractures of more than one area. Only 18 surviving passengers and 6 nonsurviving passengers had no injury to the lower limbs and pelvis.

One young child was secured on his mother's knee using a supplementary lap belt (seat 3F). Both the mother and child were injured during the impact.



All fatalities were because of impact trauma. The Accident may be divided into nine scenarios as follows:

**Scenario 1** represents the flight deck area containing two-flight crew, both of whom were seriously injured. The survivability chain for this area is:

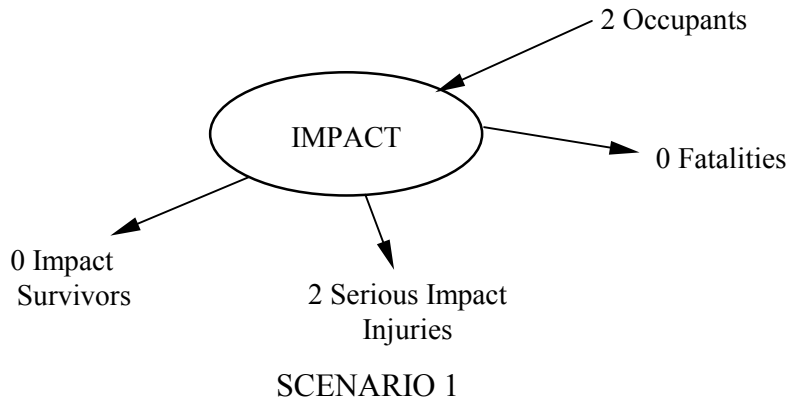

**Scenario 2** represents that area of the cabin in which the two forward flight attendants were located, both of whom were seriously injured. The survivability chain for this area is:

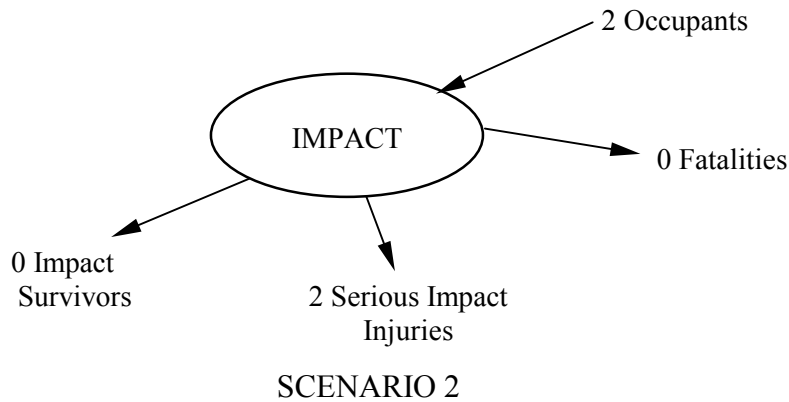

**Scenario 3** represents that portion of the passenger cabin between seat rows 1 and 5 inclusive. There were 24 passengers in this area, 12 sustained fatal injuries and 12 were seriously injured. The survivability chain for this area is:

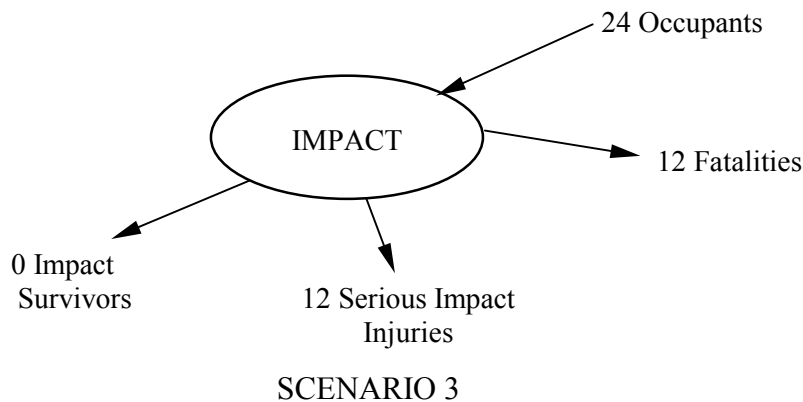

**Scenario 4** represents that portion of the passenger cabin between seat rows 6 and 9 inclusive. There were 20 occupants in this area, 11 sustained fatal injuries, and 8 were seriously injured. The survivability chain for this area is:

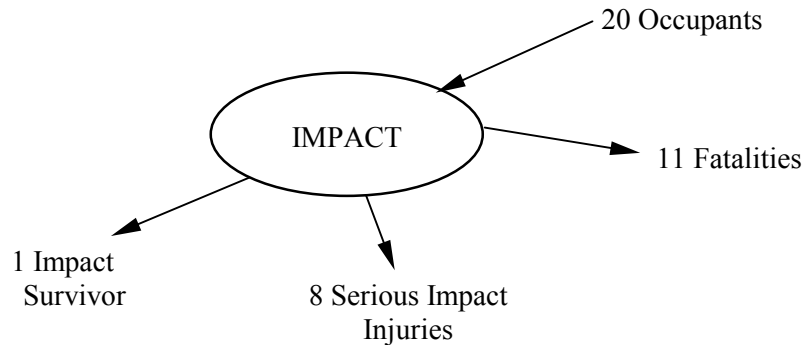

SCENARIO 4

**Scenario 5** represents that portion of the passenger cabin between seat rows 10 and 17 inclusive. There were 32 occupants in this area, 4 sustained fatal injuries, and 26 were seriously injured. The survivability chain for this area is:

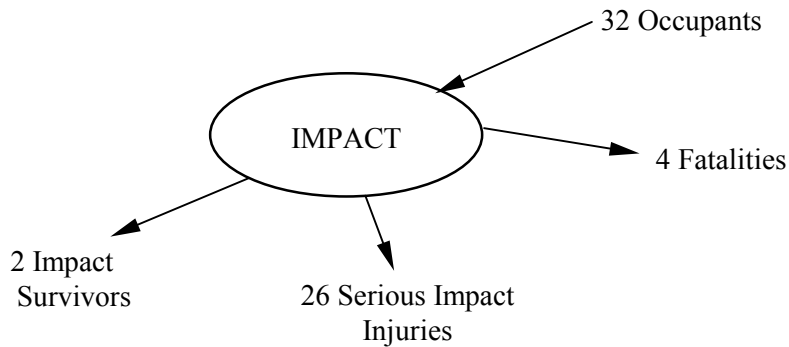

SCENARIO 5

**Scenario 6A** represents that portion of the passenger cabin between seat rows 18 to 24 inclusive on the starboard side of the aircraft and the aisle seats on the port side in rows 19 to 23 inclusive. There were 19 occupants in this area, 11 sustained fatal injuries, and eight were seriously injured. The survivability chain for this area is:

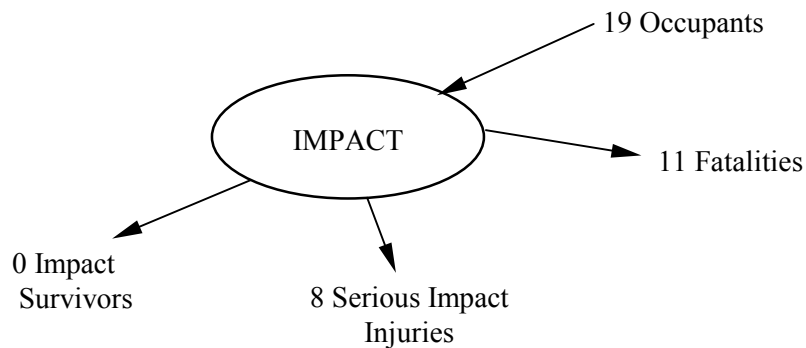

SCENARIO 6A

**Scenario 6B** represents that portion of the passenger cabin containing the port triple seat in row 18 and the port centre and window seats in rows 18 to 23 inclusive. There were nine occupants in this area all of who were seriously injured. The survivability chain for this area is:

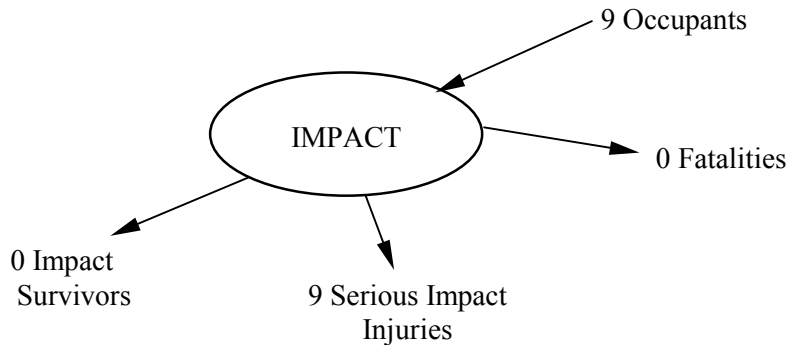

SCENARIO 6B

**Scenario 7** represents that portion of the passenger cabin from seat rows 25 to 27 on the starboard side and seat rows 24 to 27 on the port side. There were 15 passengers in this area, 1 of whom sustained fatal injuries, and 11 were seriously injured. The survivability chain for this area is:

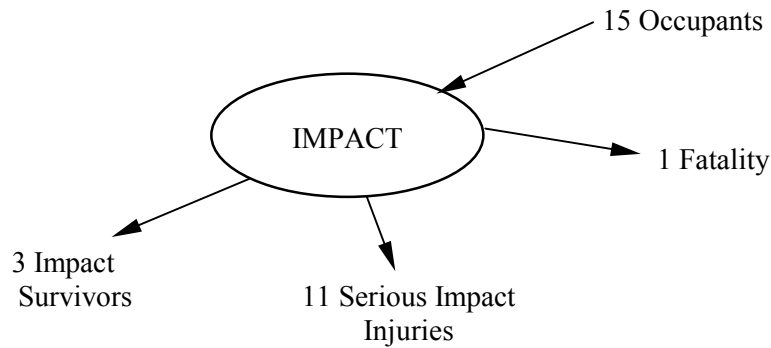

SCENARIO 7

**Scenario 8** represents that area of the cabin in which the three aft flight attendants were located, two of who were seriously injured and one survived uninjured. The survivability chain for this area is:

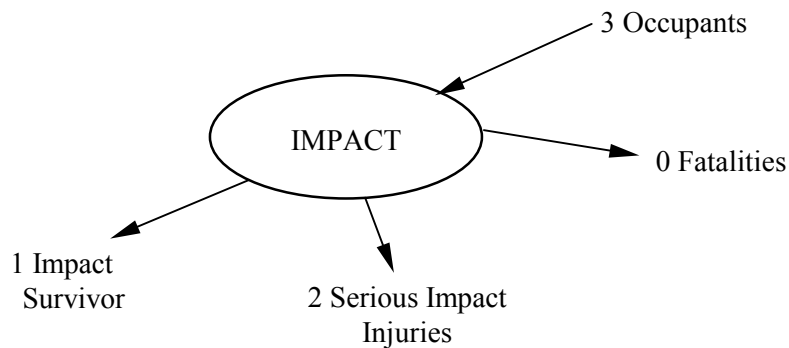

SCENARIO 8



## **EFFECT OF INTRODUCING 16-g SEATS**

The seats installed in the aircraft were tested in 1987 at the FAA Civil Aeromedical Institute (CAMI) to the standard of FAR Part 25 Amendment 25-64, which includes the 16-g dynamic load criteria. Although the tests were for development rather than certification, the results indicated that the seat would probably meet the certification criteria i.e., 16-g compatible seats. However, it is believed that it is unlikely that the seats would have been compatible with the required standard of HIC. The assessment of benefit is based on the assumption that there might be some reduction in head and facial injuries sustained by the passengers had the aircraft been configured with seats that were fully compliant with the 16-g criteria.

### **Scenarios 1, 2, 3, 4, 6B, 7, and 8**

It is assessed that there would be no reduction in the extent of injuries sustained in these scenarios had the aircraft been configured with seats meeting all of the 16-g criteria.

### **Scenario 5**

Based on the accident report data, it is assumed that all the seats in this area remained attached. If the seats had met the full HIC criteria, head, neck, and face injuries may have been substantially reduced. It is assumed that there would be no reduction in the extent of the injuries in seat row 10 due to the degree of disruption immediately in front of the occupants in this area. On this basis, the best improvement that could be expected is that there would be one fatality and three serious injuries in this scenario.

The worst situation is that there would be no improvement in the extent of the injuries sustained due to the severity of the impact. The median assessment is taken as the average of these two extremes.

The following summarises the overall assessment of the impact injuries that might result had the seats in this scenario been fully compliant with the 16-g criteria:

	<b>Minor or No Injuries</b>	<b>Serious Injuries</b>	<b>Fatal Injuries</b>
<b>High</b>	<b>2</b>	<b>26</b>	<b>4</b>
<b>Median</b>	<b>15</b>	<b>15</b>	<b>2</b>
<b>Low</b>	<b>28</b>	<b>3</b>	<b>1</b>

### **Scenario 6A**

Based on the accident report data, it is assumed that seven triple seats in this area remained attached. If the seats had met the full HIC criteria, head, neck, and face injuries may have been substantially reduced. It is assumed that there would be no reduction in the extent of the injuries in seat row 18 due to the degree of disruption immediately in front of the occupants in this area.

It is further assumed that there would be no reduction in the extent of injuries due to the disruption in the starboard seats of rows 22 to 24 inclusive. On this basis, the best improvement that could be expected is that there would be five fatalities in this scenario. It is also feasible that all of the serious injuries, other than those in the four starboard triple-seats of rows 18, 22, 23, and 24, may have sustained minor or no injuries.

The worst situation is that there would be no improvement in the extent of the injuries sustained due to the severity of the impact.

The median assessment is taken as the average of these two extremes.

The following summarises the overall assessment of the impact injuries that might result had the seats in this scenario been fully compliant with the 16-g criteria:

	<b>Minor or No Injuries</b>	<b>Serious Injuries</b>	<b>Fatal Injuries</b>
<b>High</b>	<b>0</b>	<b>8</b>	<b>11</b>
<b>Median</b>	<b>3</b>	<b>8</b>	<b>8</b>
<b>Low</b>	<b>6</b>	<b>8</b>	<b>5</b>

## ACCIDENT REF: 19890310A

Date:	10-Mar-1989	Flight Phase:	Takeoff
Aircraft:	F28	Location:	Dryden

### DESCRIPTION OF ACCIDENT

#### RESUME

On Friday, March 10, 1989, at approximately 12:11p.m. Central Standard Time, Fokker F-28 Mk 1000 bearing Canadian registration C-FONF took off from the Dryden Municipal Airport. The aircraft failed to gain height in snow conditions and continued on a flat flight path, crashing into a densely wooded area.

Fuel from the damaged tank began vaporizing and trailing behind the aircraft in the form of a mist. The mist ignited and the fire followed the aircraft to its resting position.

There were 65 passengers and a crew of 4 on board. In all, 21 passengers and 3 crewmembers, including the captain, the first officer, and 1 of the 2 flight attendants died as a result of the crash and the fire.

#### IMPACT

At the end of the takeoff run, the aircraft only lifted a few feet into the air. The aircraft was unable to gain any altitude and began contacting treetops.

As the aircraft began hitting the trees, the flight attendant shouted to passengers to brace themselves, telling them to grab their ankles and keep their heads down. In the rear of the aircraft a passenger shouted similar commands, as did a passenger at the front. Twenty survivors reported heeding her instructions. All survivors, including those who had not heard the flight attendant's commands, had assumed some semblance of the brace position prior to the aircraft striking the ground.

The survivors reported hearing the aircraft initially begin hitting the trees. As the aircraft descended lower into the trees, battering sounds were increasingly more severe and the aircraft was shuddering increasingly more violently. The sound of the aircraft striking trees and the sound of tearing metal, up to and including the final ground impact, was accompanied by passengers' screams and yells. A passenger seated in the midsection of the aircraft reported looking up prior to the aircraft striking the ground and observing passengers being rocked about, items falling from the overhead luggage racks, fuel entering the cabin area and dousing the passengers, and a flash of fire. After ground impact and prior to the aircraft shuddering to a complete stop, passengers, still with their heads down in the brace position, observed a large quantity of dirty wet snow entering the cabin. This snow was mixed with mud and sections of trees. A strong smell of fuel also accompanied the influx of this debris.

Calculations resulted in longitudinal deceleration levels of approximately 1.33 g's for the first part of the crash sequence. It was estimated that the average longitudinal deceleration levels on the second part were 2.33 to 3.05 g's due to the increase in sliding resistance once on the ground. Local deceleration levels at the front and left side of the fuselage were calculated to be 15 to 20 g's vertically and 21 to 28 g's horizontally yielding a resultant of 26 to 34 g's.

The undercarriage was in transit up when major trees contact occurred.

The aircraft had broken into three parts and lay in the woods in the shape of a large U. The front portion of the aircraft, compressed to the left, formed one arm of the U; the main fuselage, the passenger cabin portion of the aircraft, formed the base; and the tail section lay parallel to the nose of the aircraft.

Survivor statements indicated that all seat belts held; however, seven survivors stated that they had some difficulty releasing their seat belt buckles. Some because of their agitated state, some because, since their bodies had shifted in their seats during the crash, the buckles were not positioned where expected, and some because their access to the seat buckles was restricted by debris.

It was found that many of the passenger seats were detached from the floor and were bunched in the forward portion of the aircraft. Most of the passenger seat frames were damaged and distorted as a result of the impact and deceleration forces.

Five survivors stated that they had not assumed the brace position.

Five survivors stated that their seat collapsed as a result of the accident; 32 stated that their seat had not collapsed.

Nineteen survivors indicated either having been struck by an object or hitting something during the crash sequence. Two survivors stated that their head struck the seats in front of them. Nineteen passengers recall having overhead racks falling on top of them.

## FIRE

The evidence shows that when the aircraft began to strike the trees, the left fuel tank ruptured. Fuel from the tank began vaporizing and trailing behind the aircraft in the form of a mist. The fuel ignited, and there is evidence of fire along the aircraft's path through the trees from a point about 50 m after entering the trees to the final resting spot of the aircraft.

The fuel vapour plume was probably ignited from the heat of the left engine and/or the severed energized electrical components and wiring exposed during the breakup of the left wing. The fuel vapour plume and fire followed the aircraft to its resting position.

As the aircraft came to a halt, a large section of the forward left side of the fuselage separated, exposing the passengers seated in this area. The fire plume caught up to the aircraft and became static, initially burning debris and fuel on the left forward side of the aircraft. The fire plume, according to some witnesses, reached as high as 30 feet.

There was evidence of fuel spillage into the cabin; some passengers reported that they were soaked with fuel. Fuel from the right wing tank poured onto the ground through a blanket of snow. The snow effectively trapped the fuel vapours and prevented a fire from starting on the right side of the aircraft. The vapour plume from the left wing tank probably mixed with a cloud of snow generated during the final impact. Some of the fuel in the vapour plume entered the aircraft but, because of the snow, it remained out of its flammable range, which was fortunate in that there was an initial fire-free path out the right side of the aircraft for the ambulatory passengers. It is evident that the fuel that splashed on the surviving passengers was not in its flammable range since these passengers did not catch on fire.

The fire plume entered the aircraft through the large opening in the left forward area of the fuselage and contacted the fuselage sideliners, the overhead bins, and the combustible carry-on articles (collectively, the “interior combustibles”). The evidence indicates that burning plastics and other burning articles began dropping almost immediately onto both survivors and nonsurvivors. Because of the probable heavy concentration of fuel vapour that entered the aircraft and saturated the interior combustibles, the rate of flame spread was very fast. The left forward area, where the fire entered the aircraft, was where most of the deceased were found. From there the fire then spread forward into the cockpit and rearward along the cabin ceiling, igniting all interior combustibles. Toxic and flammable gases travelled through convection heating to the ceiling and out through openings in the fuselage. The fire burned from the top down, as evidenced by the fact that the top of the aircraft was burned away while the lower portions of the fuselage remained intact.

The fire was fuel regulated because of the breaks in the aircraft; there was adequate oxygen to support combustion, and the fire would burn as long as there was material to burn or until the fire was extinguished. It is not likely that fuselage flashover occurred as the large openings in the fuselage allowed the heated gases to escape and, accordingly, the fire propagated normally. The fire was most intense in the forward left area of the fuselage as evidenced by the complete destruction of this area; in contrast, a good portion of the right side of the fuselage was not burned to the same extent.

All passenger seats had been upholstered with fire-blocking neoprene foam material.

Despite the presence of sophisticated firefighting equipment and many firefighters, no attempt was made to extinguish the fire until approximately 1 hour 50 minutes after the crash. Firefighters at the scene of the crash became distracted by the injured passengers and tried to assist and provide comfort to the survivors, in the conviction that there were no survivors left inside the wreckage.

#### EVACUATION

There were 2 flight crew, 2 cabin crew, and 65 passengers aboard. The aircraft was configured with 65 passenger seats, 1 of which was occupied by a flight attendant and 1 seat had an in-lap infant.

Nine survivors responded that they had not paid specific attention to the flight attendant's demonstration.

Eighteen survivors replied that they had not read the evacuation card.

From the testimony, it was apparent that the abrupt stop rendered many surviving passengers momentarily stunned or unconscious.

The interior of the cabin sections was dimly lit by overcast daylight entering through the windows and through the two large gashes in the aircraft's right side. The interior lighting system was off, and the aircraft's emergency strip lighting either malfunctioned or, because of the debris, was not visible.

There were already a few spot fires in the interior and on the exterior of the cabin. These fires increased in intensity, and the most severe one, just forward of the left wing, propagated rapidly. The fires soon filled the cabin sections with extremely thick black acrid smoke, severely restricting visibility inside the broken cabin enclosure and rendering normal breathing extremely difficult.

When the tail section swung away from the fuselage, the last row of seats, row 13, remained with it. Some passengers found themselves almost in the open on the right side of this section and easily exited the aircraft. One passenger fell into the gap between the fuselage and the tail section. He was then stepped on while he lay there, until fellow passengers dragged him to a safer position.

Passengers from row 8 back to the rear of the aircraft found that escape out the front of the aircraft was blocked by what seemed to be an impenetrable wall of debris. The left wing of the aircraft had disintegrated during the aircraft's descent through the trees, and a curtain of fire blocked escape to the left. A passenger seated beside the leftside emergency exit at row 8, was the only survivor to escape through that exit, suffering severe burns to his hands in doing so. Passengers seated in the rear of the cabin went through either the opening in the fuselage at the rear of the aircraft or through the right-hand window exit. This exit may have been partly blocked, either inside or outside the fuselage, and those who exited this way could not determine if their point of egress was in fact the emergency exit.

One passenger was travelling with his wife and two children. After assisting his wife and one child exit the burning wreckage he returned to the aircraft, where he helped an estimated 12 passengers to escape the aircraft. At the front of the wrecked aircraft, surviving passengers faced even greater dangers. Here the fire moved the fastest, and here the cabin area was compressed by the crash forces. It was from row 7 forward, and principally on the left side of the aircraft, that the majority of the fatalities occurred.

Fourteen survivors, including a baby held in her mother's arms, evacuated through a gash in the fuselage just forward of the right wing. Twenty-six evacuated through the opening aft of the

right wing, and one severely injured survivor egressed through an opening forward of the left wing.

The survivor from seat 8E believed the emergency exit door had already been opened; he is certain he did not open it. The passenger in seat 7D stated that while he was pinned in his seat, he reached behind to his right side and twisted and pulled a latch. He could not positively identify the latch, but he may in fact have pulled in the emergency exit door.

On the left side of the aircraft, two passengers were later found pinned in the wreckage and were extricated by rescuers; it was not until nearly an hour after the crash that these two men were freed from the burning wreckage.

The surviving flight attendant, despite her emotional shock, provided some of the leadership required to keep the groups close together. Once out of the aircraft she commanded those survivors still exiting to continue moving well away from the fire; then, while waiting for evacuation from the site, she ensured that survivors, many of whom were suffering from shock, did not wander off into the woods.

Most of the survivors made their way out of the woods along the path made by the first rescuers on the scene. The first group of survivors reached Middle Marker Road less than 20 minutes after the crash. Many of these people, suffering from burns and other injuries, departed the crash site in their shirt-sleeves and stocking feet. They were put into vehicles or sent to a nearby house to keep warm. All were subsequently transported to the Dryden hospital.

#### AIRCRAFT FACTORS

The aircraft was a Fokker F28 Mk1000 bearing Canadian registration C-FONF.

The cabin had 13 rows of passenger seats, each row comprising a triple- and a double-seat unit separated by an aisle.

The fuselage had a main door at the front with a service/emergency door opposite. There were two overwing emergency exits.

#### ENVIRONMENTAL CONDITIONS

The temperature was at the freezing point and the snow was hip deep. All the survivors were poorly dressed for exposure to these conditions. The majority had removed their winter coats and jackets on the aircraft in preparation for the flight to Winnipeg. Eleven of the 47 survivors, including the flight attendant, lost their footwear during the crash or while extricating themselves from the aircraft. Some passengers removed their jackets to allow others with no shoes to stand on them, and others gave up their shirts or sweaters to those who were cold.

The flight attendant's outer clothing comprised slip-on shoes, a light dress, and a sleeveless vest. She lost one shoe in the aircraft and the other outside the aircraft in the snow. She eventually

borrowed a pair of shoes from a passenger, enabling her to better help the survivors. It was concluded that more attention should be paid to all flight attendants' clothing in a manner that will allow them to better provide the leadership required of them in an emergency.

Since the trail to the wreckage was through deep snow, rescue services could not initially get their vehicles close to the aircraft.

#### INJURIES TO OCCUPANTS

Twenty-one passengers and 3 crewmembers died as a result of the crash. Forty-four passengers and 1 crewmember survived. Most of the passengers who died were seated in the left and front portion of the aircraft. The majority of the bodies recovered at the crash site were badly burned in the subsequent aircraft fire, which made it difficult to determine the various injuries and specific causes of death. All the fatalities were investigated and their body shift, major injuries, suspected cause of death and gross estimate of survival time were documented.

Twenty-two people died at the site; one died in hospital 3 hours after the crash and one 11 hours after the crash. Of the 45 people who survived the crash, 18 required hospitalisation. One passenger suffered bronchospasm and wheezing secondary to cold exposure or fumes.

#### ACCIDENT SCENARIOS AND SURVIVABILITY CHAINS

This accident is divided into three separate scenarios, as shown in figure A-5.

It should be noted that since the g levels in this area were assessed to have exceeded 16 g's, no benefit is assigned from an improved seat standard. If these were not the case, scenario 2 would have been divided into smaller scenarios.



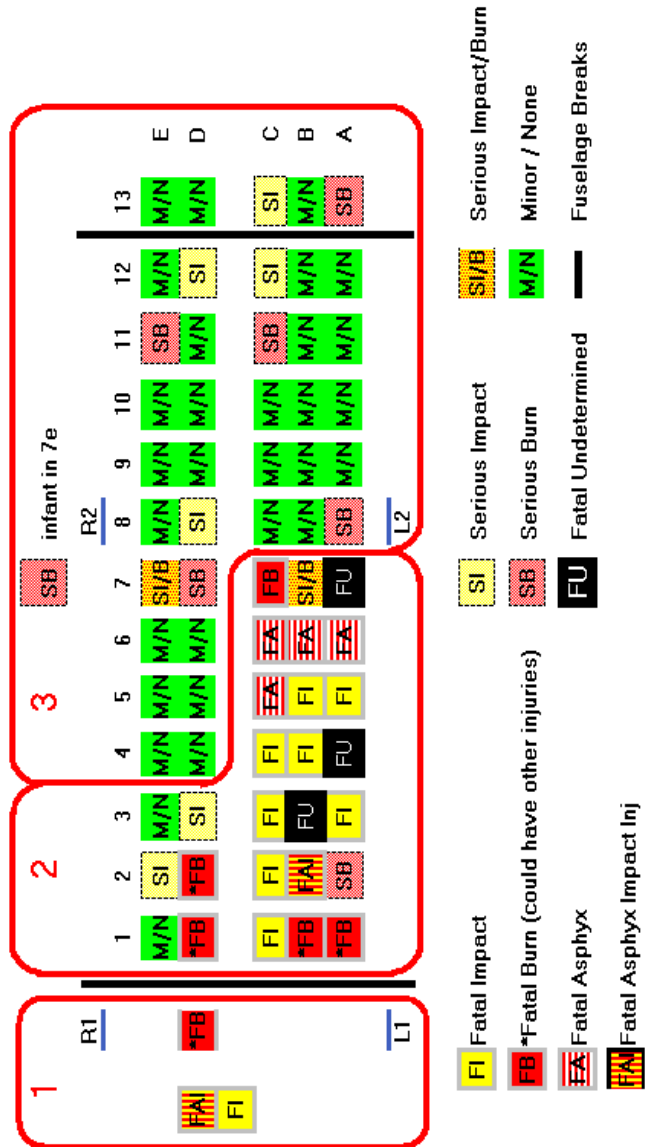
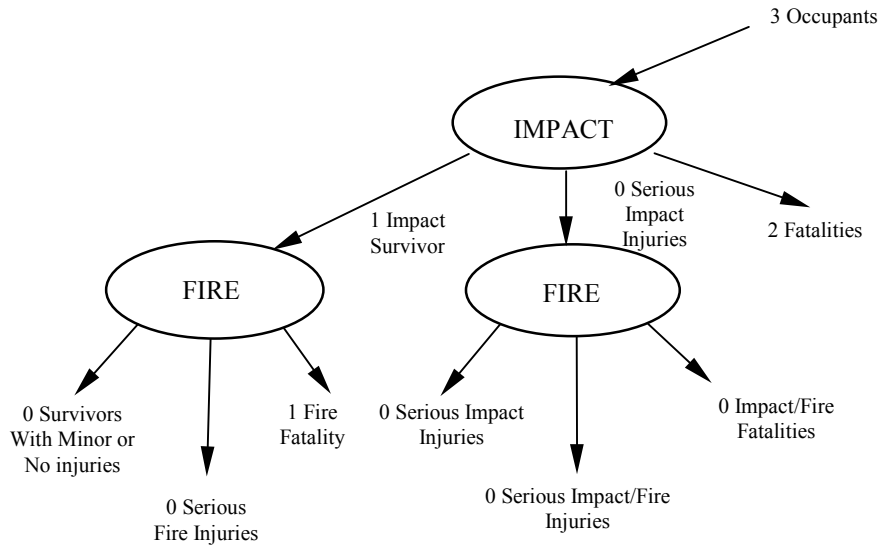

FIGURE A-5. LOCATION OF INJURIES AND SCENARIOS

**Scenario 1** contains the flight deck and vestibule where two flight crew died from impact and 1 cabin attendant died from fire burns.



SCENARIO 1

**Scenario 2** contains the forward passenger cabin area (rows 1 to 3 and 4 to 7, seats A, B, and C) where there were eight impact-related fatalities, five fire burns fatalities, four asphyxiation/toxicity fatalities, one fatal impact/fire injury, three undetermined fatalities, two serious impact injuries, one serious fire injury, and one serious impact/fire injury. The aircraft accident report stated that the bodies recovered at the crash site were badly burned in the subsequent fire, which made it difficult to determine the various injuries and specific causes of death. Therefore it is assumed that those occupants who suffered fatal fire burns could have sustained other injuries before the bodies were burned; i.e., they might have died of impact but because the bodies were subsequently badly burned, the earlier injuries could not be identified.

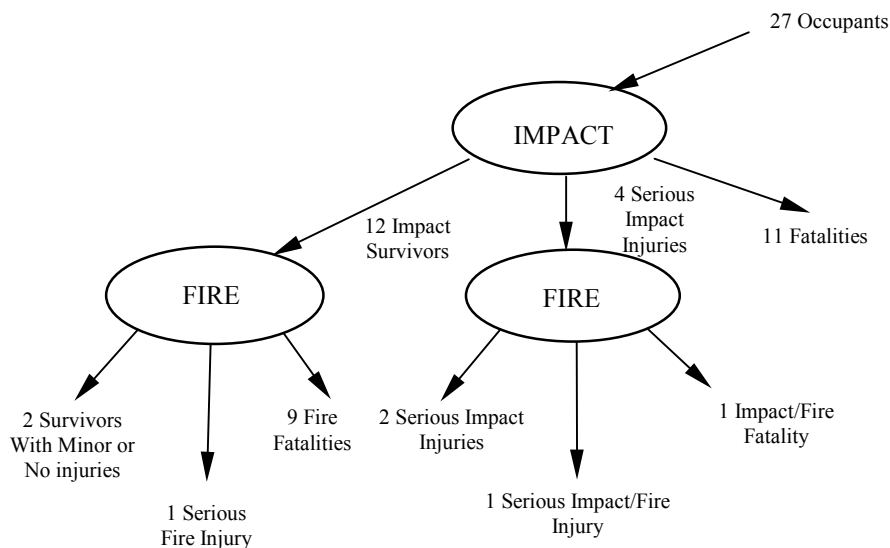

SCENARIO 2

The passenger seats in this section were severely deformed at the seat beams. The majority of these seats were subjected to deceleration forces with significant components in the sideward and downward directions during the final phase of the crash. Therefore it is assumed that the three undetermined fatal passengers died from impact injuries.

**Scenario 3** contains the rest of the passenger cabin – Rows 8 to 13 and 4 to 7, seats D and E. This scenario contained 38 passengers plus 1 infant. From the injury profile, 4 passengers suffered serious impact injuries, 1 passenger suffered serious impact and fire injuries, 5 passengers and 1 infant suffered serious fire burns, and 28 passengers received minor or no injuries.

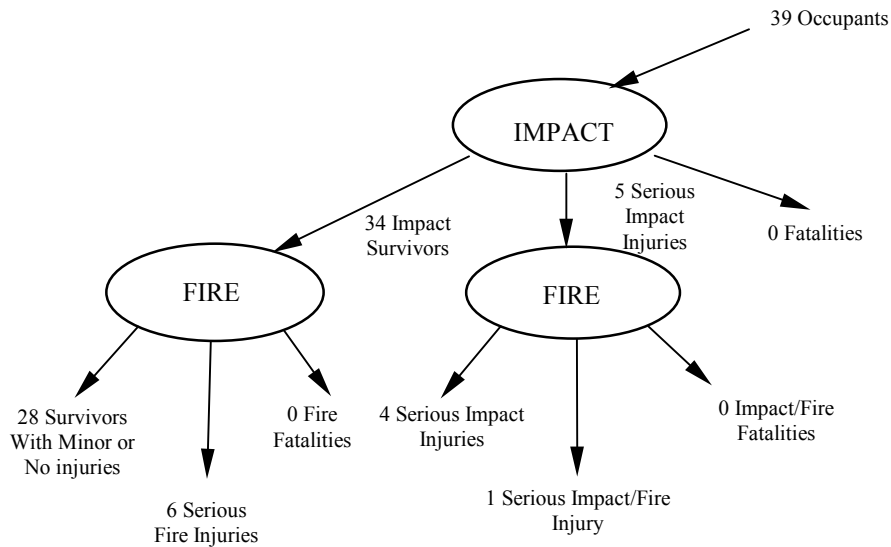

SCENARIO 3

**EFFECT OF INTRODUCING 16-g SEATS**

Scenario 1

This scenario contains only flight and cabin crew seats therefore benefit from the introduction of 16-g passenger seats is not applicable.

Scenario 2

Many of the passenger seats in this section were detached from the floor and there was severe seat beam deformation. The resultant deceleration levels at this section of the fuselage were calculated to be 26 to 34 g's. Therefore it is concluded that 16-g seats would not have altered the injury pattern in this scenario.

### Scenario 3

The deceleration force experienced in this section was less severe than in scenario 2; however, only the seats in rows 6, 7, and 9 on the right side of the fuselage were still in place after the crash. The seats in rows 13 right and 8 left suffered very little frame damage, but they were dislodged. The rest of the passenger seats in this section were detached from the floor. Many passengers suffered cuts and bruises during the impact.

The aircraft was configured with fire-blocking seat cushions but the cabin materials did not meet the heat release standards required by current regulations. It is optimistically assumed that had the cabin materials met the current regulations there would have been no fire injuries in this scenario. The survivability chain is therefore modified as follows:

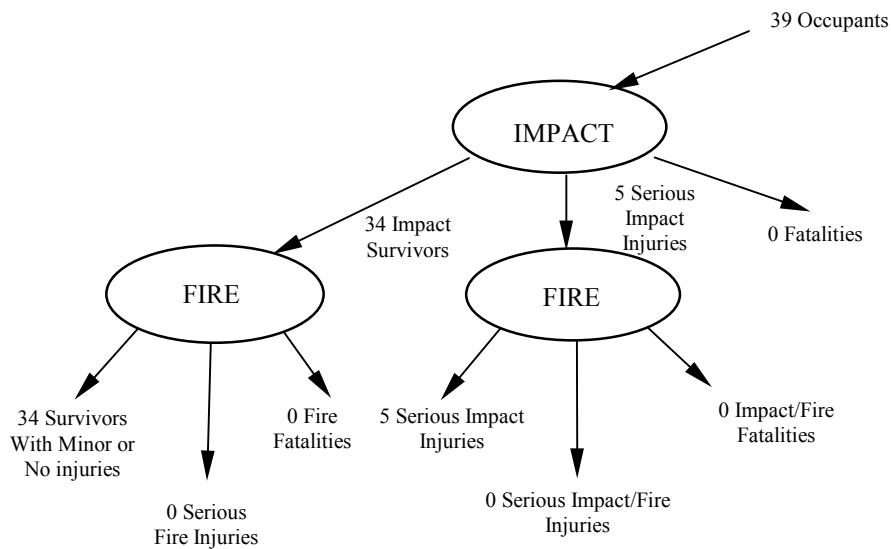

### SCENARIO 3

With 16-g seats the number of serious impact injuries in this section might have been reduced. On this basis, the best estimate is that the five passengers with serious impact injuries would have been saved.

The high, median, and low predictions of the number of impact fatalities and injuries resulting from the use of 16-g seats are:

	<b>Minor/No Injuries</b>	<b>Serious Injuries</b>	<b>Fatal Injuries</b>
<b>High</b>	34	5	0
<b>Median</b>	39	0	0
<b>Low</b>	39	0	0

## ACCIDENT REF: 19890719A

Date:	19-Jul-1989	Flight Phase:	Cruise
Aircraft:	DC10	Location:	Sioux City

### DESCRIPTION OF ACCIDENT

#### RESUME

On 19-Jul-1989, at 1516, a DC-10-10, N1819U, operated by United Airlines as flight 232, experienced a catastrophic failure of the No. 2 tail-mounted engine during cruise flight. The separation, fragmentation, and forceful discharge of stage 1 fan rotor assembly parts from the No. 2 engine led to the loss of the three hydraulic systems that powered the aeroplane's flight controls. An off duty check airman assisted the crew by controlling the aircraft using only the engine power levers.

The aeroplane touched down on the threshold slightly to the left of the centerline on runway 22 at 1600. First ground contact was made by the right wing tip followed by the right main landing gear. The aeroplane skidded to the right of the runway and rolled to an inverted position. Witnesses observed the aeroplane ignite and cartwheel, coming to rest after crossing runway 17/35. Firefighting and rescue operations began immediately, but the aeroplane was destroyed by impact and fire.

There were 285 passengers and 11 crewmembers onboard. One flight attendant and 110 passengers were fatally injured.

#### IMPACT

The senior flight attendant was called to the cockpit and was instructed by the Captain to secure the cabin and prepare for an emergency evacuation. She did not ask the captain for the amount of time available until the aircraft would land because she thought the flight crew was too busy. The second officer told her to use the Short Notice Emergency Landing Preparation. She separately informed the other flight attendants but did not notify the passengers straight away because she did not want to alarm them. Survivors related that the Captain's announcement to the passengers stated that the flight attendants had briefed the passengers about the brace position. However they had not yet been briefed. The senior flight attendant began reading the "Short Notice Cabin Preparation" briefing after the Captain concluded his announcement.

Passengers were in protective brace positions, seatbelts were tightly fastened, and the cabin was properly secured.

There were four in-lap Infant occupants onboard. Three of them were under 24 months, and one was 26 months old. During the preparations for the emergency landing, parents were instructed

to place their infants on the floor and to hold them there when the parent assumed the protective brace position.

About 11 minutes before landing, the landing gear was extended by means of the alternate gear extension procedure.

The aeroplane's right wing tip, right main landing gear, and the nacelle for the No. 3 engine contacted the runway during the initial touchdown sequence. The aeroplane tumbled as it continued down the runway.

The airplane separated into four major sections: the cockpit, the first-class cabin, the main cabin, and the empennage section.

Cockpit Section - The cockpit separated from the fuselage aft of the forward cabin doors (L1 and R1). The cockpit was destroyed and came to rest in two large pieces.

The captain's seat was deformed forward and to the right. The seatback was attached, and the restraint system was intact except for the seatbelt tie-down strap which had pulled through its attachment clip at the base of the seat. Also, the right lap belt and shoulder straps were found cut.

The first officer's seatback was separated in the forward direction and to the right. The seat support pedestal was also deformed to the right. The restraint system remained attached and the buckle was operative. The inertia reel remained intact and operative.

The flight engineer's seat support pedestal was attached to a piece of the cockpit floor and was deformed to the right. The seatback had separated from the seat pan in the forward direction and to the right. The shoulder harness was operative and was attached to the seatback. The lap belts and tie-down strap were found attached and the buckle was operative including the shoulder harnesses.

The first observer seat which was occupied by the flight engineer during the impact was found entrapped in the cockpit wreckage still attached to its floor segment. The restraint system was attached and operative.

The second observer seat was found entrapped in the cockpit wreckage and partially attached to its floor structure. The seat frame was deformed and the lower seat pan attachment slider bars were dislodged, consistent with secondary impact damage on the bottom of the seat pan. This seat was unoccupied at the time of the accident.

An L1 flight attendant jump seat was separated from the airplane and partially destroyed. An R1 flight attendant's jump seat was destroyed and found near the cockpit wreckage. The second R1 flight attendant jump seat was not found.

First-Class Cabin Section - The first-class cabin separated from the fuselage at approximately BS 655 on the left side and approximately BS 775 on the right side. The first-class cabin was destroyed by impact forces and sustained some exterior fire damage.

Passenger seats were found inside and near the first-class cabin wreckage. There was some impact and fire damage to the frames but fire-blocking material mostly protected the seat cushions. Some seat legs had been sawn off in the rescue process.

Main Cabin Section - The main cabin separated from the empennage. The main cabin was destroyed by postcrash fire after coming to rest inverted approximately 3750 feet from the initial impact point. The ceiling structure was collapsed to just above the window belt over the wingbox.

The left side of the ceiling from the L3 overwing exit aft of the wing at about BS-1701 was collapsed and buckled due to the inverted fuselage and subsequent fire. The R3 exit was destroyed by fire and was found lying next to the fuselage in a molten condition. The right side passenger floor from R3 aft had four sets of passenger seat legs that remained attached to the floor track, the upper portion of these seat legs had been sawed off by rescue workers. The same was noted in the center aisle.

Empennage Section - The empennage section separated from the main cabin section at about BS 1881, at or near the production joint. The cabin forward of about BS 1781 to about BS 1701 was destroyed during the impact sequence, releasing its contents along the wreckage path.

The fuselage aft of about BS 1781 remained partially intact and came to rest on its right side. Ten passenger seats, two flight attendant jumpseats, and the aft galley remained intact.

The aft galley wall panel was displaced forward, but was undamaged. Four food service carts were found in each side of the galley and all were stowed and locked in place. The galley as a unit was undamaged. Food stuffs had spilled, and coffee pots were missing. All galley doors were found closed and locked with food stuffs spilled inside.

The flight attendant seat at the L4 door was in place and it could be lowered, retracted and the head rest articulated. The seat back and head cushion was missing. The shoulder harness and seat belt were intact and functional. The PA microphone and interphone were found on the floor.

The ceiling panels on the left side of the cabin were displaced downward to about 5 feet 6 inches from the floor. Both of the left side lavatory doors were operable with no significant damage noted. Both of the right side lavatory doors could be opened. The inboard lavatory oxygen mask was deployed and the firing lanyard was intact and had not been pulled.

The floor-mounted stowage compartment forward of the L4 jump seat was intact and the inboard door would close but would not latch; the outboard compartment's door would latch. The flashlight located on top of the stowage compartment was in its receptacle and was functional. Various ceiling and center cabin panels were displaced downward.

The center cabin divider which was located aft of seat row 38 was separated from its floor and ceiling attachments and the ceiling mounts had separated. The left side Airphone was missing while the right side Airphone was in place. An oxygen bottle and fire extinguisher restraint bracket were in the center compartment of the divider; however, the oxygen bottle and fire extinguisher were missing.

The R4 flight attendant jump seat and its restraint system were functional; however, the seat was loose from its attachments due to structural separations.

The floor-mounted stowage bin forward of the R4 flight attendant jump seat was in place. The inboard door was deformed and could not be closed. The outboard door was missing. The flashlight mounted on top of the stowage bin was in place but the light was not functional.

The remaining passenger seat tracks extended to about BS 1886.5 and floor panels were found dislodged throughout. Floor beams on the left side of the airframe were cracked at the intersection of the seat tracks between about BS 1825.5 and about BS 1886.5.

Seat units were in relatively good condition. In general, front seat legs showed compression buckling and rear seat legs remained attached to the floor track. Track breaks were noted about 20 inches aft of the left front legs. Seat belts were intact and operational.

#### FIRE

There was no evidence of in-flight fire. A postcrash fire erupted during the crash breakup of the aircraft. A deep-seated fuel-fed fire took place in the main cabin wreckage.

The aircraft came to rest in a cornfield. The cornstalks on the airfield adversely affected firefighting operations.

Flight Attendant No. 3 situated in the main cabin said that when they first crashed there was a light smoke that he saw coming inside the aircraft at the rear. The light smoke "kind of evaporated" and a few seconds later, it got thicker. Eventually a heavy black smoke that he described as "unbearable" moved from the back forward.

There was extensive fire damage forward of the L3 and R3 overwing exits with a number of seats destroyed by fire, including the L3 and R3 flight attendant jumpseats.

The L2 and R2 doors and the L2 and R2 flight attendant jumpseats were destroyed by the postcrash fire.

#### EVACUATION

The crew consisted of a captain, first officer, second officer, and eight flight attendants. In addition an off-duty check airman was aboard and assisted the flight crew by controlling the aircraft down to the point of touchdown.



There were 285 passengers aboard and the aircraft seating was configured to accommodate 287.

With the exception of two elderly passengers who died of asphyxia from smoke inhalation, all of the occupants in rows 9-21 were able to evacuate in spite of smoke from the postcrash fire. Although most passengers were able to escape without assistance, several passengers stated that they were assisted by other passengers.

The aircraft came to rest in a corn field. The height of the plants was some hindrance to people as they left the aircraft and located other survivors outside the wreckage. Flight Attendant No. 7 had to force corn plants apart to step out of the aircraft. It was further concluded that cornstalks on the airfield adversely affected firefighting operations.

The main cabin came to rest inverted and most of the cabin crew had difficulty extracting themselves from their harnesses.

Flight Attendant No. 1 saw a crack of light and heard people say there was an opening. She went to the opening and started pushing people through. The opening was large enough for people to walk out standing upright. She exited into the cornfield and moved away from the aircraft.

Flight Attendant No. 3 exited the aircraft by crawling on what he thought was air conditioning vents. It appeared to him that everyone that could get out in that section was getting out.

Flight Attendant No. 4 told passengers to follow her and she saw an opening with sunlight and she told people to “go for that.” She estimated that 20 to 30 people from rows 22 to 25 followed her out. She said the people seemed very calm and were not pushing each other. They were moving rapidly, but not panicking or trampling each other. She said passengers were helping one another. Someone helped her out and told her to go out by the cornfield.

The L1 door was found adjacent to the cockpit wreckage in its frame that had separated from the fuselage. The slide pack was partially exposed but remained in place. The girt bar remained in place. The air bottle gauge showed zero pressure; however, the slide did not inflate. Multiple tears were noted on the exposed portion of the slide.

The R1 door separated from its door frame and a portion of the door frame separated from the fuselage. The door was bent in the center, and all of its attachment hardware, the slide pack, and decorative panels were missing. The slide pack was located about 30 feet from the door.

Damage to the R1 slide consisted of two small punctures midway down the center of the sliding surface. The air bottle remained attached and the gauge showed zero pressure. The slide did not appear to have been inflated.

The L2 and R2 doors were destroyed by the postcrash fire.

The L3 exit sustained substantial fire damage but remained intact with the upper third collapsed at the same level as the rest of the fuselage. The slide pack remained in place, but it was destroyed by fire.

The L4 door's slide-ARM/DISARM handle was found in the "slide ARMED" position. The handle's guard cover was not attached and was found hanging next to the handle. The door was found opened inward about 1 inch at its forward and aft edges. The slide was disarmed during inspection and could not be rearmed.

The R4 aft cabin door was found open. The door's emergency control handle was in the stowed position. The slide handle was in the "ARMED" position and the red "T" section on the door emergency control handle was missing. Structural damage to the R4 door frame was consistent with the fuselage breakup.

The R4 evacuation slide was found deployed where the tail section had come to rest. The air bottle gauge indicated zero pressure. The auto and manual slide inflation lanyards were separated from the inflation bottle. The manual inflation handle had not been activated. The girt bar was attached to the slide. The slide's inflatable tubes had two tears approximately 6 inches long.

#### AIRCRAFT FACTORS

The aircraft was a DC-10-10 registered in the United States as N1819U.

There were four plug type floor level cabin doors on each side of the airplane. The doors were normally operated electrically from either inside or outside the airplane with a pneumatically powered opening capability provided for emergency operation.

The forward lavatories that were located forward of the left (L1) and right (R1) cabin doors were separated by a storage closet, a wide aisle, and the cockpit entry door. Double-occupancy aft facing flight attendant jumpseats were attached to the aft side of each lavatory's bulkhead. Two single-occupancy aft facing flight attendant jumpseats were attached to lavatory bulkheads at the left mid-cabin boarding door (L2) and the right galley service door (R2). Single-occupancy aft facing flight attendant jumpseats were located forward of the overwing cabin doors (L3 and R3) and forward of the aft cabin doors (L4 and R4).

The 287 first-class and economy-class seats were in cabin zones A, B, and C.

Zone A, contained the first-class cabin, forward galleys, and forward lavatories. It extended from the cockpit entry door to just aft of the L2 and R2 mid-cabin doors. The 28 first-class leather covered seats were configured with 5 double-occupancy forward facing seat units on the left and right sides of the cabin and 4 double-occupancy seat units in the center. Seat rows were numbered 1 through 5 on the left and right sides and 1 through 4 in the center.

Zone B, which contained economy-class seats, extended from aft of the mid-cabin doors to just aft of the overwing cabin doors (L3 and R3). The 113 economy-class seats were configured with 12 double-occupancy forward facing seat units on the left and right sides and 13 quintuplet (triple- and double-occupancy seat units combined) in the center. Seat rows were numbered 9 through 20 on the left and right sides and 9 through 21 in the center.

Zone C, which also contained economy-class seats, extended from aft of the overwing cabin doors to the rear of the cabin at the aft galley and included the aft cabin doors (L4 and R4). The 146 economy-class seats were configured with 16 double-occupancy forward facing seat units on the left and right sides and 14 quintuplet and 3 quadruple (two double-occupancy seat units combined) in the center. Seat rows were numbered 23 through 38 on the left and right sides and 22 through 38 in the center.

Weber Aircraft had either manufactured or refurbished the passenger seats. The first class seats were designed and manufactured by Weber Aircraft. The economy-class seats were designed and manufactured by Universal Oil Products (UOP), Hardman, and TransAero, and were refurbished by Weber Aircraft under contract with United Airlines. All seats met TSO-C39 and incorporated seat cushion fire blocking.

#### ENVIRONMENTAL CONDITIONS

The accident occurred during daylight conditions at 42° 25' north latitude and 96° 23' west longitude.

The surface weather observation taken at Sioux Gateway Airport at 1559 estimated a ceiling of 4,000 feet with broken clouds and 15 miles visibility. The temperature was 80°F and winds were 360° at 14 knots. There were towering cumulus clouds in all quadrants. The last wind reported to the crew by the tower at 1558 was from 010° at 11 knots.

Weather was not considered a factor in this accident.

#### INJURIES TO OCCUPANTS

Of the 296 persons aboard the aeroplane 110 passengers and 1 flight attendant were fatally injured. Autopsies revealed that 35 passengers died of asphyxia due to smoke inhalation, including 24 without traumatic blunt force injuries. The other fatally injured occupants died of multiple injuries from blunt force impact. Of the remaining 185 persons onboard, 47 sustained serious injuries, 125 sustained minor injuries, and 13 were not injured.

The ceiling structure collapsed throughout the fuselage; however, the greatest amount of collapse was found in the area near the left wingbox. Consequently, passengers in that section of the fuselage had less space available in which to extricate themselves from their seats and escape. Thirty-three passengers in this section died of smoke inhalation: 12 of those 33 passengers had blunt trauma injuries that may have incapacitated them or slowed their escape; the other 21 persons did not sustain blunt trauma injuries. Escape for those passengers seated on the left side

of cabin in rows 22-30 was hampered by the hazardous combination of fuselage crush and immediate exposure to the smoke entering the fuselage. Most passengers on the right side of the cabin in rows 22-30 were able to escape because there was less crushing in that area.

The other fatalities resulted from blunt force impact injuries. These passengers were located in areas where the structural integrity of the airplane was destroyed during the impact sequence.

Thirty-three of the 35 occupants who died from asphyxia secondary to smoke inhalation were in the section of the fuselage containing rows 22-30. Two other occupants in seats 14A and 16D died of asphyxia due to smoke inhalation.

The woman in 14J stated that her son “flew up in the air” upon impact but that she was able to grab him and hold onto him. Details of what happened to the 26-month-old child at 12B during the impact sequence are not known, but he sustained minor injuries. The mother of the 11-month-old girl at 11F said that she had problems placing and keeping her daughter on the floor because she was screaming and trying to stand up. The mother of the 23-month-old at 22E was worried about her son’s position. She kept asking the flight attendants for more specific instructions about the brace position and her “special situation with a child on the floor.” The mothers of the infants in seats 11F and 22E were unable to hold onto their infants and were unable to find them after the airplane impacted the ground. The infant originally located at 11F was rescued from the fuselage by a passenger who heard her cries and re-entered the fuselage. The infant held on the floor in front of seat 22E died of asphyxia secondary to smoke inhalation.

### **ACCIDENT SCENARIOS AND SURVIVABILITY CHAINS**

This accident is considered as having thirteen scenarios, as shown in figure A-6. It should be noted that of the 285 passengers, detailed information from the accident report is provided for only 284.

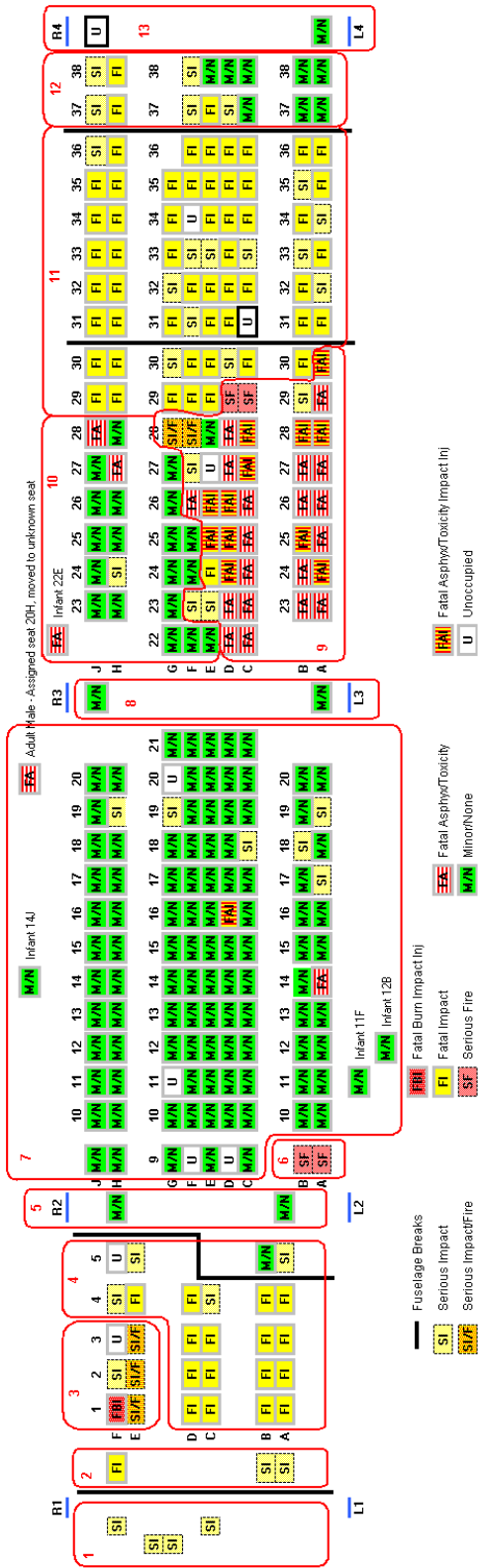
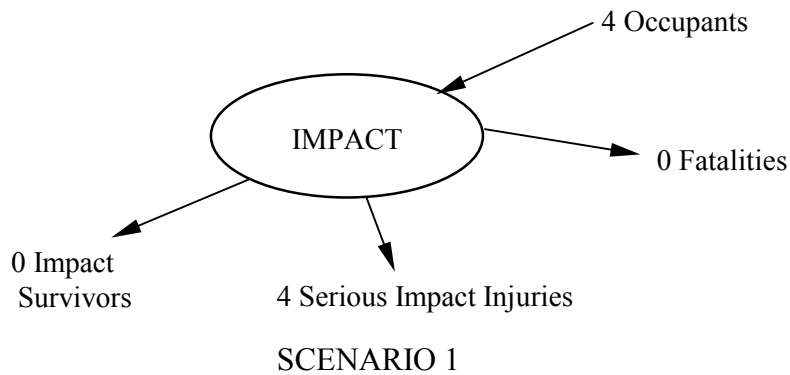
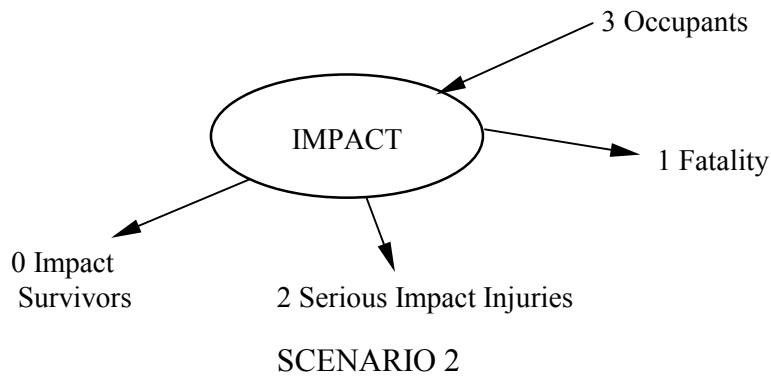

FIGURE A-6. LOCATION OF INJURIES AND SCENARIOS

**Scenario 1** represents the cockpit area where it is assessed that the three flight crewmembers and the occupant of the jump seat were located—all of whom survived although serious impact injuries were encountered.



**Scenario 2** represents the area occupied by the forward flight attendants, one of whom sustained fatal impact injuries and the remaining two sustained serious impact injuries.



**Scenario 3** represents seats 1E, 1F, 2E, 2F, 3E, and 3F. There were five occupants of this scenario, one of who sustained fatal injuries. The remaining four were seriously injured.

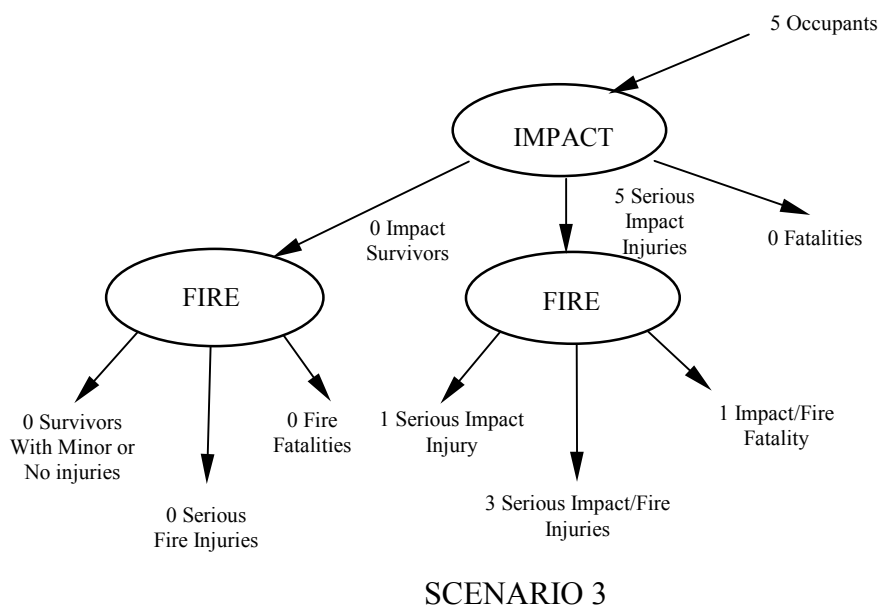

**Scenario 4** represents the remainder of the first-class cabin. It is assessed that this portion of the cabin contained 21 occupants of whom 16 sustained fatal injuries as a result of impact trauma.

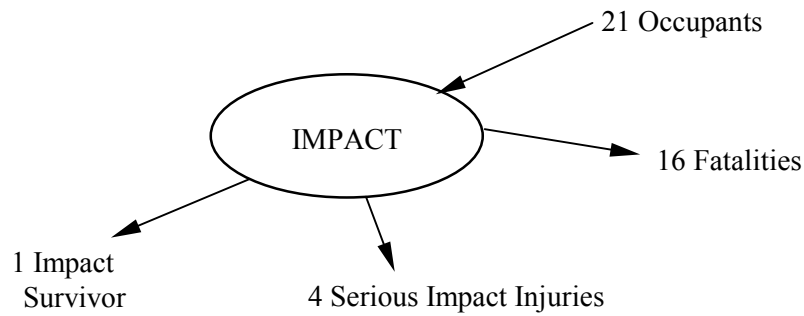

SCENARIO 4

**Scenario 5** represents the area occupied by the R2 and L2 flight attendants, both of whom escaped serious injury.

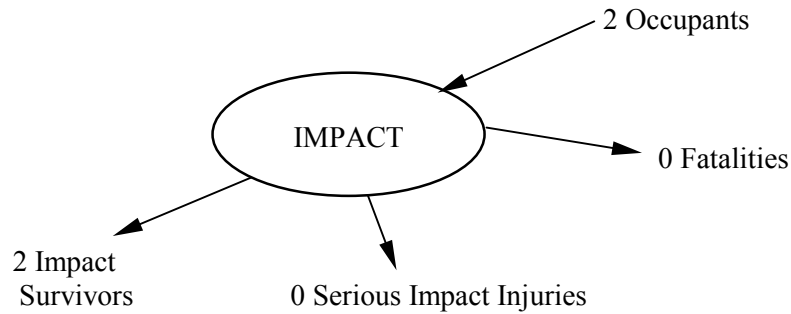

SCENARIO 5

**Scenario 6** represents the area in which seats 9A and 9B were located. The occupants of these seats both sustained serious burns.

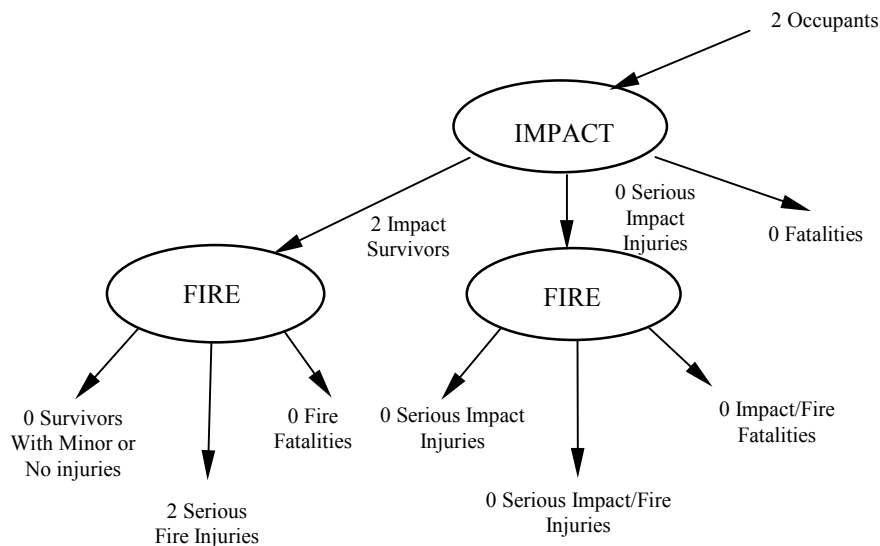

SCENARIO 6

**Scenario 7** represents the remainder of the passenger cabin from seat rows 9 to 21 inclusive. It is assessed that this portion of the cabin contained 111 occupants of which 3 were fatalities resulting from asphyxiation.

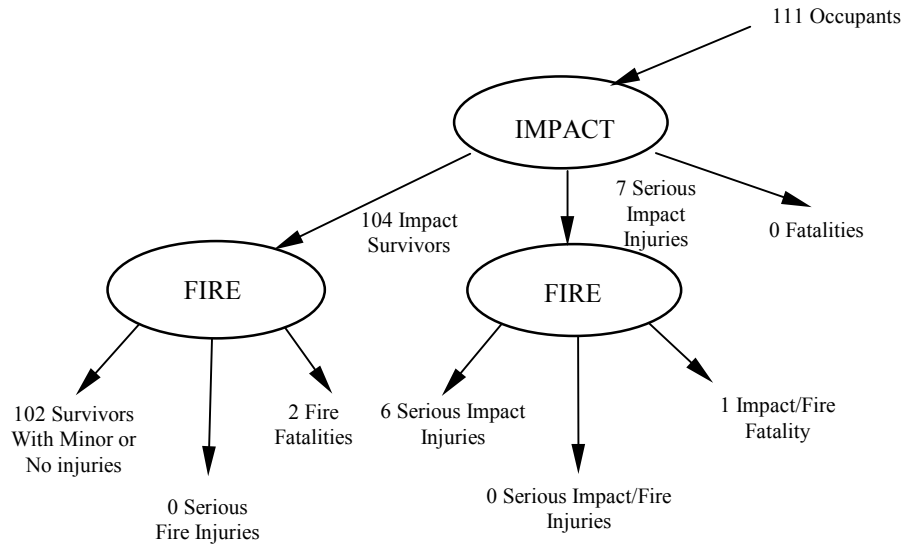

SCENARIO 7

**Scenario 8** represents the area occupied by the R3 and L3 flight attendants, both of whom escaped serious injury.

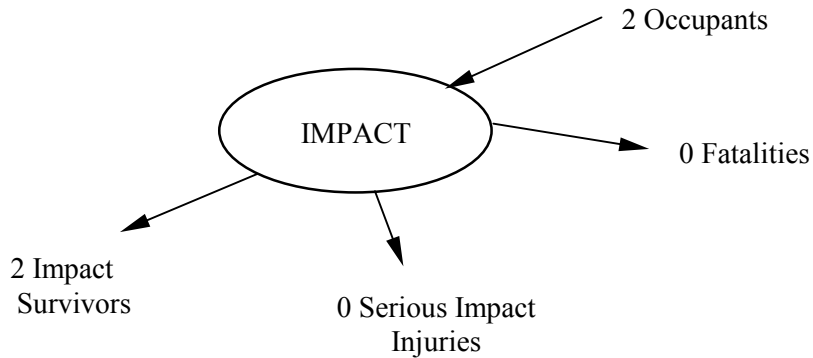

SCENARIO 8



**Scenario 9** represents the area of the main cabin in which the majority of occupants suffered fatal injuries from asphyxiation.

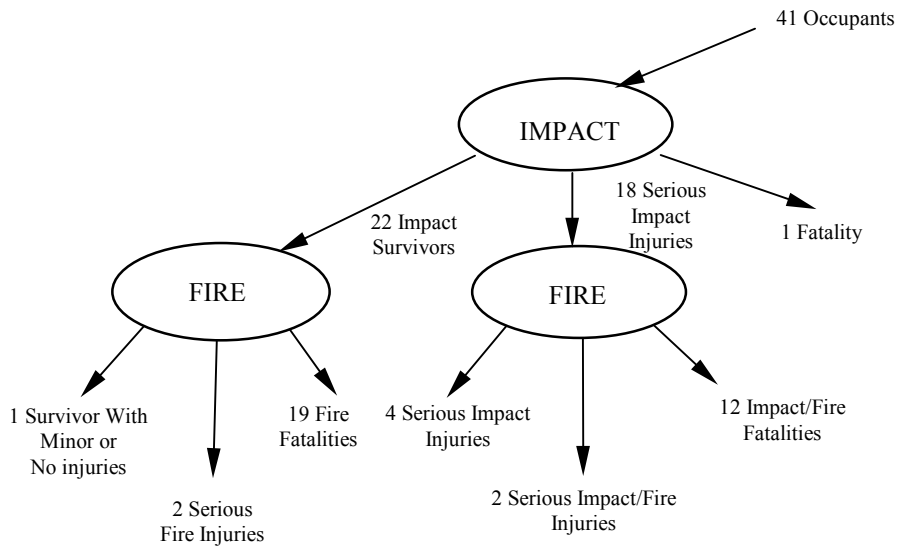

SCENARIO 9

**Scenario 10** represents the area of the main cabin directly opposite from Scenario 9, in which many occupants escaped with minor or no injuries.

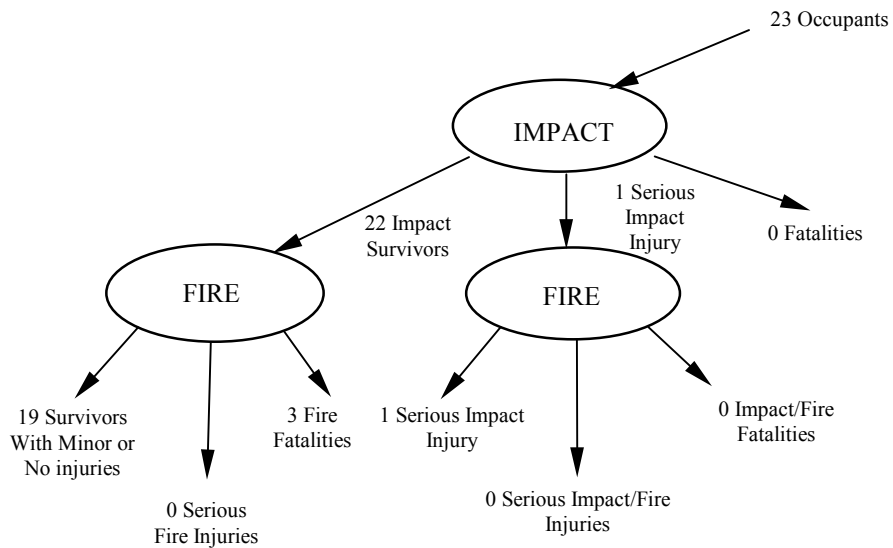

SCENARIO 10

**Scenario 11** represents the remainder of the passenger cabin aft to seat rows 36. It is assessed that this portion of the cabin contained 64 occupants of which 52 sustained fatal injuries as a result of impact trauma.

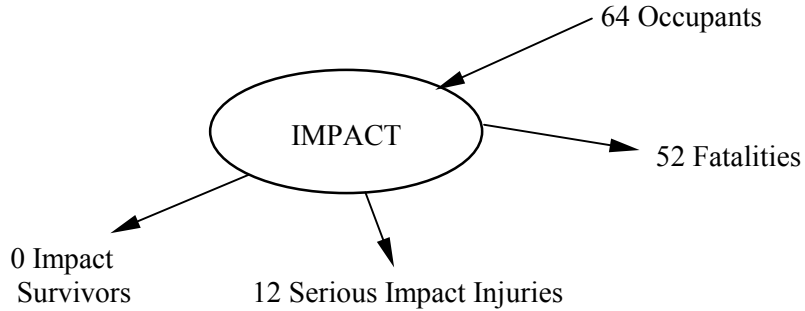

SCENARIO 11

**Scenario 12** represents the passenger cabin aft of seat row 36. It is assessed that this portion of the cabin contained 16 occupants of which 3 sustained fatal injuries as a result of impact trauma.

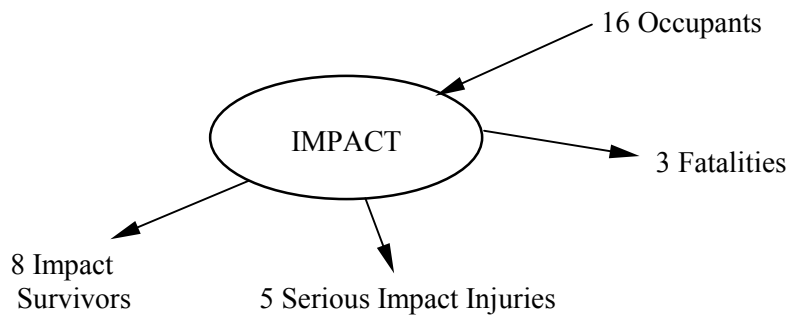

SCENARIO 12

**Scenario 13** represents the area occupied by the aft flight attendant, who escaped serious injury.

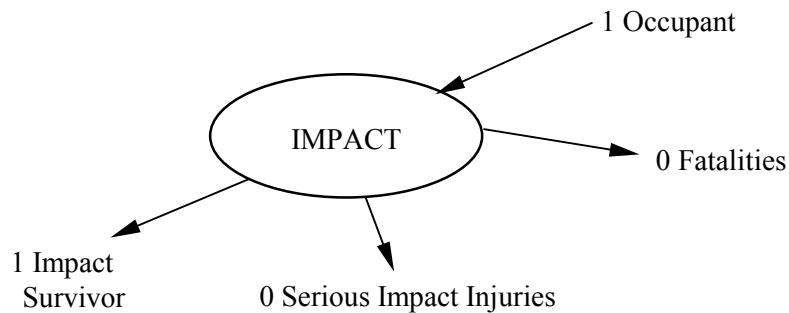

SCENARIO 13

## **EFFECT OF INTRODUCING 16-g SEATS**

### Scenario 1

This scenario contains only flight crew seats and therefore benefit from the introduction of 16-g passenger seats is not applicable.

### Scenario 2

This scenario contains only cabin crew seats and therefore benefit from the introduction of 16-g passenger seats is not applicable.

### Scenario 3 and 4

The first-class cabin was reportedly destroyed by impact forces and it was therefore assessed that impact injuries would not have been avoided by the introduction of 16-g seats.

### Scenario 5

This scenario contains only cabin crew seats and therefore benefit from the introduction of 16-g passenger seats is not applicable.

### Scenario 6

There were no injuries sustained that were related to the impact forces and therefore no benefit was assessed for the introduction of 16-g seats.

### Scenario 7

The cabin in this scenario was inverted and occupants were held upside down until they released their seat belts. Six of the occupants sustained serious impact injuries. Of these only two reported any failures of seats; i.e., the occupant in 17A felt separated seats below her and the occupant in 19A reported that her seat fell on top of her as she climbed out of it.

It is therefore assessed that there were seat failures along the left side of the cabin in this scenario but there were only three occupants with serious impact injuries in this area. Hence, the maximum benefit (low assessment) is taken as the reduction of three serious injuries.

The high assessment is based on the three serious injuries being caused by impacts with objects other than seats.

The median assessment is taken as being between the high and the low.

The high, median, and low predictions of the number of impact fatalities and injuries resulting from the use of 16-g seats are:

	<b>Minor or No Injuries</b>	<b>Serious Injuries</b>	<b>Fatal Injuries</b>
<b>High</b>	<b>104</b>	<b>7</b>	<b>0</b>
<b>Median</b>	<b>106</b>	<b>5</b>	<b>0</b>
<b>Low</b>	<b>107</b>	<b>4</b>	<b>0</b>

Fire is not considered a significant threat for occupants in this scenario.

### Scenario 8

This scenario contains only cabin crew seats and therefore benefit from the introduction of 16-g passenger seats is not applicable.

### Scenario 9

From the survivor statements, there were no reported seat failures in this scenario. Furthermore, there was significant deformation of the ceiling, which trapped the occupants and prevented them from escaping the ensuing fire. Therefore, it is assessed that there would be no additional benefit from the introduction of 16-g seats.

### Scenario 10

From the survivor statements, there were no reported seat failures in this scenario. The seat legs were found still attached to the floor and had been sawn through by rescuers. Therefore, it is assessed that there would be no additional benefit from the introduction of 16-g seats.

### Scenario 11

In this scenario, structural integrity was lost during the impact sequence and the ceiling was reportedly collapsed and buckled. The cabin aft of about row 31 was destroyed by impact. Many passengers died from blunt force impact injuries were located in this section.

It is assessed that some seats were detached during the impact sequence, as the structural integrity was lost. This is consistent with the statements from the surviving passengers. One passenger (33B) stated that during the impact, he was “tossed” around and landed in the cargo compartment down below his seat. Another passenger (33F) said she found herself sitting upright in her seat looking around at the green corn field. A surviving passenger (seat 28G) at another section stated that as she walked through the cornfield, she passed other passengers lying on the ground who were bloody and dirty. She believed that they had been ejected from the aircraft.

It is most likely that these ejected passengers came from this scenario. Due to the extent of the impact it is considered unlikely that there would be any significant reduction in the number of fatalities or serious injuries resulting from the introduction of 16-g seats. However seat failure did occur and injuries may have been sustained by passenger's heads striking the seat in front. It is therefore assumed that there may be some potential for reduction in injuries. On this basis, the low assessment is based on the assumption that the number of surviving passengers might have doubled from 12 to 24. However, as with the other surviving passengers they would have sustained serious injuries.

The high, median, and low predictions of the number of impact fatalities and injuries resulting from the use of 16-g seats are:

	<b>Minor or No Injuries</b>	<b>Serious Injuries</b>	<b>Fatal Injuries</b>
<b>High</b>	<b>0</b>	<b>12</b>	<b>52</b>
<b>Median</b>	<b>0</b>	<b>12</b>	<b>52</b>
<b>Low</b>	<b>0</b>	<b>24</b>	<b>40</b>

### Scenario 12

There should be 16 passenger seats in this scenario, however it was stated in the accident report that there were only 10 seats contained in this section. Therefore, 6 passenger seats were detached during the impact sequence which was consistent with the survivors' statements that seat detachments occurred.

Therefore, it can be assumed that if 16-g seats were fitted on the aircraft, there is the possibility that 3 of the impact fatalities and 3 of the serious impact injured passengers could have been saved.

The high assessment assumes that no benefit would have been gained from the introduction of 16-g seats. The low assessment assumes that all 3 fatally injured passengers would have been saved and a modest reduction of 3 serious injuries. The median assessment is taken as the average of the high and the low assessments.

The high, median, and low predictions of the number of impact fatalities and injuries resulting from the use of 16-g seats are:

	<b>Minor or No Injuries</b>	<b>Serious Injuries</b>	<b>Fatal Injuries</b>
<b>High</b>	<b>8</b>	<b>5</b>	<b>3</b>
<b>Median</b>	<b>10</b>	<b>5</b>	<b>1</b>
<b>Low</b>	<b>13</b>	<b>3</b>	<b>0</b>

### Scenario 13

This scenario contains only cabin crew seats and therefore benefit from the introduction of 16-g passenger seats is not applicable.

## ACCIDENT REF: 19890920A

Date:	20-Sep-1989	Flight Phase:	Takeoff
Aircraft:	B737	Location:	LaGuardia

### DESCRIPTION OF ACCIDENT

#### RESUME

On 20-Sep-1989 a USAir Boeing 737-400 registered as N416US was departing from New York City's LaGuardia Airport, Flushing, New York. Instrument flight conditions prevailed and the runway was wet. The flight was operating under Title 14, Code of Federal Regulations Part 121.

As the first officer began the takeoff, he felt the aircraft drift left. The captain noticed the left drift also and used the nosewheel tiller to help steer. As the takeoff run progressed, the aircrew heard a bang and a continual rumbling noise. The captain then took over and rejected the takeoff but did not stop the aircraft before running off the end of the runway into Bowery Bay.

The aircraft was destroyed.

Of the 6 crew and 57 passengers aboard, 2 passengers suffered fatal injuries. Three passengers suffered serious injuries. Six crew and 49 passengers escaped with minor or no injuries. Hospital records were not available for three passengers.

#### IMPACT

The captain had flown the previous segment and the first officer was to be the flying pilot on this segment. During the preflight checklist the rudder was inadvertently mistrimmed to full left trim.

The aircraft began tracking to the left during the takeoff roll. About 18 seconds after beginning the roll, the CVR recorded a bang followed by a loud rumble. The captain later said that during this time the aircraft continued tracking to the left and that he was becoming concerned about the unidentified bang and rumble. The first officer later said he believed he had stopped the leftward tracking and the aircraft began to parallel with the runway centreline.

The crew continued to have difficulty with directional stability when the captain rejected the takeoff. He said that he used differential braking and nose wheel steering to return toward the centreline and stop.

The aircraft did not stop on the runway but crossed the end of the runway at 34 knots ground speed. It came to rest in the water supported by the pier that holds the runway's approach lights. Both pilots agreed that the farthest the aircraft tracked to the left during the rejected take off (RTO) was about halfway between the centreline and the left side of the runway. Both said that during the RTO they thought the aircraft could be stopped on the remaining runway.

The aircraft collided with a wooden approach lighting stanchion or pier as it went off the end of the overrun. The fuselage separated into three sections with the forward section resting on part of the elevated light stanchion and the aft section partially submerged. All fuselage fractures were due to overstress. At seat rows 4 and 21, the fuselage received localised severe vertical forces where the approach light pier structure penetrated and separated the lower fuselage.

The bottom of the nose aft of the nosewheel well had heavy impact damage. Fragments of the pier penetrated the cockpit floor near the captain's rudder pedals. The nose gear was extended and both nosewheel tyres were attached to their wheel rims but were deflated and worn away to expose carcass plies near the centre of the tread. More wear was on the left sides of both nose tyres. The tyres on both main landing gears were inflated and showed normal wear.

The one forward and two aft flight attendants seats had no damage.

The wreckage was not secure on the wooden pilings and in the water so tidal movements made on-site examination of the wreckage unsafe. Salvage and transport to a secure aircraft hangar damaged the wreckage. Therefore determining the presalvage condition of the passenger seats was impossible. Deceleration was not high enough to dislodge or overstress any seats or to separate any seat belts or shoulder harnesses. Separation and subsequent crushing of the fuselage caused the most severe seat damage in rows 21 and 22. Massive crushing of one seat and the floor occurred in row 21 on the left side of the aircraft.

#### FIRE

No fire occurred during or after the accident.

#### EVACUATION

There were 2 flight crew, 4 cabin crew, and 57 passengers aboard.

Immediately following the impact, the captain performed the Passenger Evacuation checklist. He verbalised the steps of this checklist as he was sitting in his seat. The captain, the first officer, an off duty Pan American captain, flight attendants, and an airport police officer who jumped into the water from the runway deck assisted the passengers during the evacuation.

The flight attendants immediately reacted when they realised that the takeoff was deteriorating. As the aircraft departed the runway's deck, they told passengers to brace. As soon as the aircraft came to rest, they independently assessed their assigned exit and initiated, as appropriate for their exit, an evacuation. The L4 and R4 flight attendants assessed their exits and saw that there was less water at R4.

Depending upon where the passengers were seated, their evacuations were impeded by darkness, cabin separations at seat rows 4 and 21, and the unavailability of floor level exits on the left side. Seat damage and floor disruption delayed the evacuation of passengers seated in 21F and 22A.



The lead flight attendant could not open the L1 door after the aircraft came to a stop. The flight attendant seated nearest the R1 door opened that door with the help of the lead flight attendant. The evacuation slide at R1 deployed; the R4 slide was disarmed before the door was opened because the flight attendant believed that the slide would float upward and block the exit because of the closeness of the water. The L4 door was opened and then closed when water entered the cabin. Both right overwing exits operated normally and the left overwing exits were not available for inspection; however, several passengers stated that they used the left overwing exits to evacuate successfully.

About 20 passengers stood on the left wing, which was out of the water. Someone unstowed the fabric ditching line from above a left overwing exit and tied it to its wing fitting. These 20 passengers, including a woman with a 5-year-old child and an 8-month-old infant, held onto the line as they awaited rescue.

The ditching line was unstowed from its right overwing exit opening, but evacuees did not know it needed to be tied to the right wing fitting. The forward portion of the right wing was out of the water and passengers held onto the ditching line so they could stay out of the water.

Passengers who egressed at the two floor-level exits entered the water and because of the 1-knot current some persons drifted away from the aircraft and under the runway deck. Crewmembers threw flotation seat cushions and crew life preservers, which were held by passengers and crewmembers, some of whom could not swim. Several persons complained that they could not hold onto the cushions or that the cushions did not keep them afloat. Some clung to pilings under the deck and floating debris. Some passengers also swallowed fuel that was on the water surface. Several complained that waves from boats and downwash from a rescue helicopter hampered staying afloat with their head out of the water. One passenger said that she sustained a fractured right ankle and a lacerated hand when a rescue boat backed over her.

The captain and the lead flight attendant were the last crewmembers to leave the cabin after assisting rescue workers who were attempting to extricate the passengers trapped in seats 21F and 22A. These passengers estimated that their extrication was completed 90 minutes after the accident.

Problems were experienced with one hand-held battery powered cabin megaphone—the other megaphone was not used. The lead flight attendant stated that he attempted to use it to give evacuation commands, but subsequently his commands were squelching (feedback) and it became more effective to simply yell the commands. Also, this megaphone ceased operating completely after it became wet later during the evacuation. During the investigation, it was discovered that the megaphone used at the USAir training centre had a volume knob that turned to the left to increase the volume. The lead flight attendant could not specify which way he operated the volume knob, or whether he operated it at all during the rescue sequence. The megaphone he used was not recovered following the accident.

The first rescue boat arrived about 10 minutes after the accident. Rescue personnel and persons who were in the water informally estimated that the last person was taken onshore well over 30

minutes after the first boat arrived. The search and rescue activities were hampered by darkness and floating debris. Further, rescue personnel did not know how many persons were onboard the aircraft, how many were in the water, and how many had been taken from the scene.

About 12 minutes after the accident, a tower ladder truck arrived and, using a combination of the tower ladder and other ladders, rescue personnel climbed down to the aircraft. These personnel assisted persons trapped in the cabin and began extrication.

During the time that passengers were in the water, flight attendants remained in control of the situation by instructing everyone to stay in groups and to help each other. In spite of the strong water current that made it difficult for survivors to stay afloat, flight attendants L4 and R4 linked arm to support two passengers who could not swim.

#### AIRCRAFT FACTORS

The aircraft was a B737-400 registered as N416US operated by USAir.

The aircraft was delivered to the operator from the manufacturer on 23-Dec-1988.

The cabin configuration was predominantly three abreast either side of a central aisle.

The aircraft exit configuration consisted of the L1 main boarding door, the R1 forward galley door, four Type III overwing exits, the L4 aft entry door, and the R4 aft galley door.

Although crewmembers had life preservers, FAA regulations did not require life preservers for passengers aboard this flight. Flight attendants had not received ditching training in the water. It was not required by the FAA.

#### ENVIRONMENTAL CONDITIONS

The accident occurred during the hours of darkness in light rain and fog.

Wind was 210 deg at 4 knots, visibility was 5 miles, and the ambient temperature was 23°C. On that day 1.72 inches of rain had fallen.

The cockpit crewmembers said that they did not use the windscreen wipers during the rejected takeoff.

#### INJURIES TO OCCUPANTS

Of the 6 crew and 57 passengers aboard, 2 passengers suffered fatal injuries. Three passengers suffered serious injuries. Six crew and 49 passengers escaped with minor or no injuries. Hospital records were not available for three passengers.

Two passengers in seats 21A and 21B died of mechanical asphyxiation (suffocation from being crushed and unable to breathe). The floor crushed upward at seat rows 21 and 22 and trapped four passengers. The passengers in 21A and 21B were trapped in seats that were crushed against the ceiling; they died of asphyxia from compression of their chests. Only immediate extraction and life support would have saved them. The other two passengers, in seats 21F and 22A sustained serious multiple injuries.

### **ACCIDENT SCENARIOS AND SURVIVABILITY CHAINS**

It was stated in the accident report that the floor crushed upward at seat rows 21 and 22 and trapped four passengers. The passengers in 21A and 21B were trapped in seats that were crushed against the ceiling; they died of asphyxia from compression of their chests. Only immediate extraction and life support would have saved them. The other two passengers, in seats 21F and 22A, sustained serious multiple injuries. Details of injuries on the third seriously injured passenger were not stated in the accident report; however, it can be assumed that the injuries were sustained during the impact or evacuation in the darkness.

As a result no accident scenarios and survivability chains have been generated for this accident.

### **EFFECT OF INTRODUCING 16-g SEATS**

Despite passenger seat failures, it is considered unlikely that there would be any reduction in the number of fatalities or serious injuries resulting from the introduction of 16-g seats. The seat failures that were reported occurred as a result of separation and crushing of the fuselage. In addition, the deceleration forces experienced in the accident were considered not high enough to dislodge or overstress any seats or to separate any seat belts or shoulder harnesses.

## ACCIDENT REF: 19900125B

Date:	<b>25-Jan-1990</b>	Flight Phase:	<b>Approach</b>
Aircraft:	<b>B707</b>	Location:	<b>Cove Neck</b>

### DESCRIPTION OF ACCIDENT

#### RESUME

On 25-Jan-1990, B707-321B registered as HK-2016 was approaching John F. Kennedy International Airport, New York.

Because of poor weather conditions in the northeastern part of the United States, the flight crew was placed in holding three times by air traffic control, for a total of about 1 hour and 17 minutes. During the third period of holding, the flight crew reported that the aircraft could not hold longer than 5 minutes, that it was running out of fuel, and that it could not reach its alternate airport. Subsequently, the flight crew executed a missed approach to John F. Kennedy International Airport. While trying to return to the airport, the aircraft experienced a loss of power to all four engines and crashed approximately 16 miles from the airport in a wooded residential area in Cove Neck, Long Island, New York.

There were 9 crew and 149 passengers aboard. Eight crew and 65 passengers suffered fatal injuries. One crewmember and 80 passengers suffered serious injuries. Four passengers escaped with minor or no injuries.

#### IMPACT

According to the lead flight attendant seated in 2C, who survived with serious injuries, there was no warning to the cabin from the cockpit crew regarding the impending emergency landing. Therefore passengers were not briefed on brace positions, other than during the pre takeoff briefing. However, after the failure of all four engines and electrical generators, the PA system would not have operated.

The aircraft ran out of fuel and impacted on an approximately 24° upsloping hill. Based on ground scars left by the engines and airframe, the entire fuselage, with the exception of the cockpit and forward cabin, came to a stop within 21 to 25 feet after impact.

The fuselage was found partially separated into three sections: the cockpit and forward cabin, the main fuselage and the aft cabin section.

The cockpit and forward cabin had broken away from the rest of the fuselage at the time of terrain impact and had continued to move over the crest of the slope, coming to rest about 90 feet forward of the main wreckage. This section was significantly damaged with seats and other cabin components lying on the ground extending back to the main wreckage.

The main fuselage had come to rest, upright on the upslope of the hill, on a heading of about 182°. The forward end of this section extended over the crest of the slope.

The right horizontal stabiliser was found attached to the empennage and was relatively undamaged. The left horizontal stabilizer was found attached to the empennage but had fractured off into two pieces approximately 4 feet outboard of the fuselage.

Interior furnishings, consisting of the galley, seat units, seat belts, overhead bins, decorative panels, and floor structure from the cockpit/forward fuselage section, were found scattered along the wreckage path between the separated forward section of the cabin and cockpit back to and into the fractured opening of the second section of the cabin. This fracture was just forward of the point where the leading edge of the wing mates with the fuselage. Interior furnishings were also scattered along the wreckage path forward of the nose of the aircraft up to a point about 100 feet beyond the final resting point of the cockpit and forward cabin section.

The interior of the cockpit was found substantially damaged. Four of the five cockpit seats (the three seats occupied by the flight crew, as well as one of the two observer jump seats, both of which were unoccupied) were lying outside of the cockpit.

The right side of the cockpit struck a 42-inch-diameter oak tree that penetrated the space occupied by the first officer and the flight engineer, causing nonsurvivable injuries.

The captain's seat was separated from the lower leg attachments to the base structure of the seat. The seat pan, back, and adjustment mechanisms were found generally intact. There were no shoulder straps or inertial reel installed on the pilot's seat. The base of the seat was attached to a 3- by 4-foot section of the cockpit's flight deck. That section of floor was the largest section of the floor from within the cockpit found intact. The floor, although separated in several places, was flat without significant deformation.

The first officer's seat was substantially damaged. The seat back was separated from the seat frame and was not located. The seat adjustment mechanism was intact. The left and right sides of the lap belt and rotary type release buckle were on the seat and were operational. There were no shoulder straps and no inertial reel for shoulder straps with the seat assembly.

The flight engineer's pedestal-type seat was lying outside the cockpit. The seat was equipped with a four-point restraint system, and the inertia reel for the single shoulder harness was damaged but still attached.

There was substantial damage inside the overwing section of the cabin. Interior furnishings, consisting of passenger seat units, overhead bins, and decorative panels, were piled up outside the forward opening. There was a fracture of the longitudinal floor track beam, evidenced by a downward disruption of floor panels between two lateral floor beams. The remainder of the cabin floor was generally intact but was displaced downward about 3 inches on the right side. The inboard rear legs of 16 seat assemblies remained attached to the floor track in the overwing

section. The outboard legs of these assemblies were fractured at the floor track. These seats were found outside the cabin and forward of the overwing section.

The aft cabin section was open at its forward end. Most of the seats in this section were found separated from their floor tracks. The floor panels were displaced, the aft galley and lavatories were displaced, and food from the galley was scattered throughout this section.

The aft section of the fuselage had rolled slightly to the left and came to rest on the lower one-third of the L4 aft cabin entry door, preventing the door from opening. The damage to the inside of the cabin was extensive in this area.

All four of the main fuel tanks had been punctured by trees at impact. Less than 5 gallons of fuel were found in the fuel tanks.

If the cabin crewmembers and passengers had assumed the brace position before the impact, the severity of some of the injuries might have been reduced.

Seventy-two of the 74 passengers who survived sustained serious injuries. These injuries consisted of multiple lower leg fractures and dislocations, head injuries, hip fractures, spinal fractures, and multiple lacerations and contusion. The legs of passengers probably impacted the lower seat back frames of seat units in front of them. Simultaneously, passengers seats most likely collapsed and twisted downward and to the left, resulting in hip and spinal fractures. As the impact sequence progressed, separation of the seat units from their floor attachments probably pushed passengers forward into other passengers, seat units, and other wreckage debris, causing head injuries and lacerations.

The 10 surviving infants were either held by adult passengers or were belted into the same seat with the passengers. Surviving passengers who held infants reported that during the impact the infants were ejected from their grasp and that they were generally unable to locate them in the darkness after the impact.

#### FIRE

There was no fire.

#### EVACUATION

There were 3 flight crew, 6 cabin crew, and 149 passengers aboard. The 149 passengers aboard the flight consisted of 61 adult males and 61 adult females whose ages ranged from 19 years to 77 years; 16 children, 8 males and 8 females whose ages ranged from 3 years to 15 years; and 11 infants, 8 males and 3 females whose ages ranged from 4 months to 27 months.

Most cabin doors were found opened, including the main boarding door (L1), the forward galley door (R1), and the aft galley door (R4). The left forward overwing emergency exit hatch was found in place and could not be opened because of fuselage distortion.

The emergency evacuation slide packs for doors L1 and R1 were in place and relatively undamaged. Evacuation slide inflation bottles remained partially pressurised. The emergency slide pack for the rear cabin entrance (L4) was in a significantly damaged area of the fuselage. The rear galley slide pack (R4) was missing from the door and could not be located. There were no girt bars found for any of the slide assemblies. Although the inoperable evacuation slides were not required in this accident, these deficiencies would have been a major factor in an emergency where the use of evacuation slide would be necessary.

The left aft overwing emergency exit hatch could not be located. However, it was reported by rescuers that they had removed this hatch, as well as the two overwing hatches on the right side of the cabin. They reported no difficulty in removing these hatches.

During the rescue effort, approximately 91 ambulances, heavy rescue vehicles, off-road vehicles, and fire trucks of varying sizes responded. Vehicles came from 37 fire and rescue companies. Access to the impact site created a bottleneck of traffic on a single, narrow, residential road. The police department had to dispatch helicopters to evacuate many of the injured.

#### AIRCRAFT FACTORS

The aircraft was B707-321B registered as Colombian HK-2016, operated by Avianca, the airline of Colombia.

The captain and first officer seats had no shoulder harnesses installed.

There were two floor-level exits located in the front of the cabin (L1 and R1) and two floor-level exits located in the rear of the cabin (L4 and R4). Each door was a plug type that had to be opened inward and then rotated outboard. Each floor-level exit was fitted with an automatically deployable and inflatable emergency evacuation slide. Two emergency exits were located over each wing. These exits were not fitted with evacuation slides.

#### ENVIRONMENTAL CONDITIONS

The accident occurred during the hours of darkness in fog with light rain or drizzle.

Visibility was 0.75 mile and wind was 190° at 20 knots.

#### INJURIES TO OCCUPANTS

There were 9 crew and 149 passengers aboard. Eight crew and 65 passengers suffered fatal injuries. One crewmember and 80 passengers suffered serious injuries. Four passengers escaped with minor or no injuries.

The eight crew fatalities included the three flight crewmembers and five of the six flight attendants.

The pilot and first officer sustained severe head injuries. The flight engineer sustained severe chest injuries and multiple fractures. The captain and first officer seats had no shoulder harnesses installed. The right side of the cockpit struck a 42-inch-diameter oak tree that penetrated the space occupied by the first officer and the flight engineer, causing their nonsurvivable injuries.

Sixty-four adult passengers and one 4-month-old infant died as a result of blunt force injuries. It is possible that some of the injuries could have been reduced, permitting some of these passengers to survive, if they had been instructed to assume the brace position before impact.

Seventy-two of the 74 passengers who survived sustained serious injuries. These injuries consisted of multiple lower leg fractures and dislocations, head injuries, hip fractures, spinal fractures, and multiple lacerations and contusions. The legs of passengers probably impacted the lower seat back frames of seat units in front of them. Simultaneously, passengers seats most likely collapsed and twisted downward and to the left, resulting in hip and spinal fractures. As the impact sequence progressed, separation of the seat units from their floor attachments probably pushed passengers forward into other passengers, seat units, and other wreckage debris, causing head injuries and lacerations.

Two of the 10 surviving infants sustained minor injuries, consisting of multiple contusions and abrasions. The remaining eight sustained serious injuries consisting of limb fractures and head injuries. The 10 infants were either held by adult passengers or were belted into the same seat with the passengers. Surviving passengers who held infants reported that during the impact the infants were ejected from their grasp and that they were generally unable to locate them in the darkness after the impact.

### **ACCIDENT SCENARIOS AND SURVIVABILITY CHAINS**

This accident is considered as having five scenarios, as shown in figure A-7.

Occupants with known injuries but unknown seat locations have been added to scenarios 3, 4, and 5 based on the proportion of known injuries and seat locations.





**Scenario 1** represents the cockpit area where the three flight crewmembers were located.

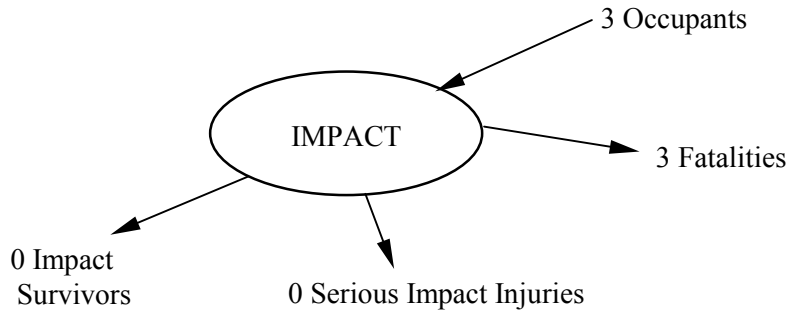

SCENARIO 1

**Scenario 2** represents the areas occupied by the flight attendants.

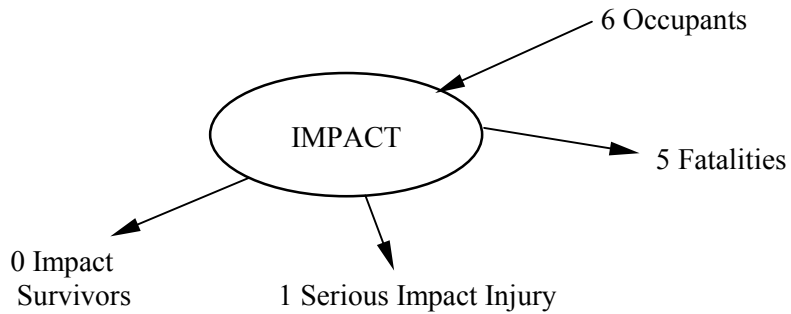

SCENARIO 2

**Scenario 3** represents passenger seat rows 1 through 8, which were located in the forward separated fuselage section.

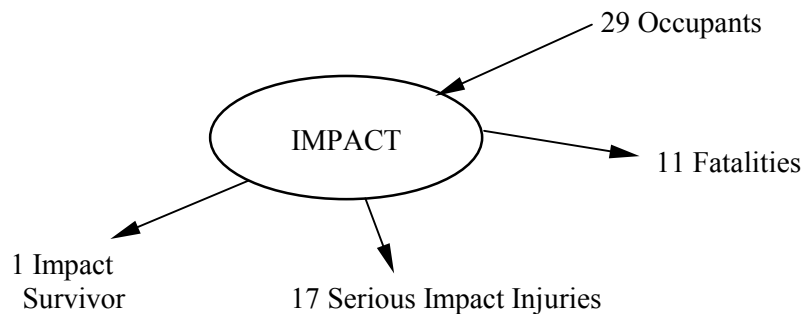

SCENARIO 3

**Scenario 4** represents passenger seat rows 9 through 24, located in the middle separated fuselage section.

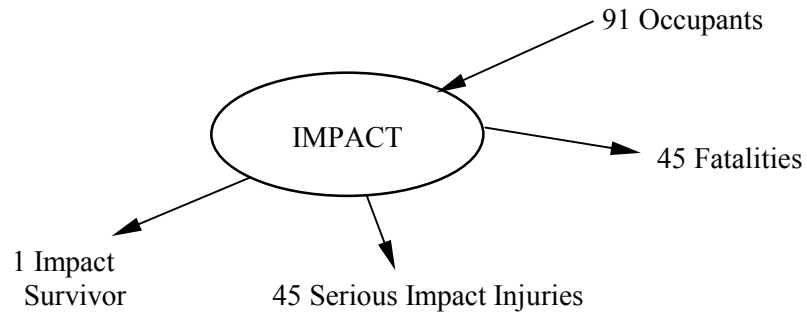

SCENARIO 4

**Scenario 5** represents passenger seat rows 25 through 29, located in the rear separated fuselage section.

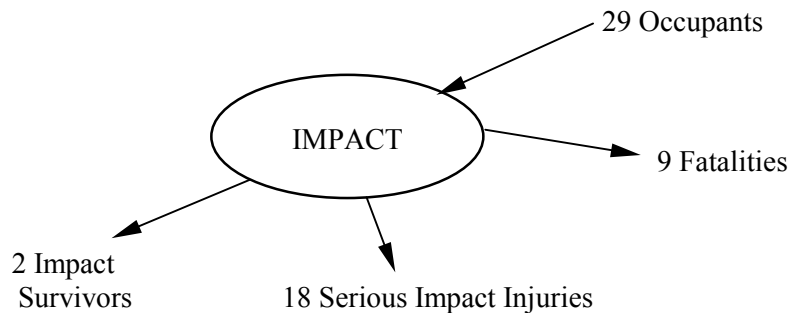

SCENARIO 5

**EFFECT OF INTRODUCING 16-g SEATS**

Scenario 1

This scenario contains only flight crew seats and therefore benefit from the introduction of 16-g passenger seats is not applicable.

Scenario 2

This scenario contains only cabin crew seats and therefore benefit from the introduction of 16-g passenger seats is not applicable.

### Scenario 3

All serious and fatal injuries in this scenario were as a result of blunt force trauma. Traumatic injuries included severe head injuries and chest injuries including transected aortas, cervical spinal fractures, basular skull fractures, hip fractures, and multiple lower leg fractures particularly at the ankles. In this scenario, seats were found detached and scattered along the wreckage path between the front and mid-fuselage sections.

The low assessment is based on 16-g seats remaining undamaged and in place, tending to restrain the occupants from injury caused by impact with separated seats. It is assessed that around half of the fatal injuries would be reduced to serious injuries and that the other half would be reduced to minor or no injuries. Furthermore, it is assumed that all adult serious injuries would be reduced to minor or no injuries. The uninjured infant is assumed to be in this scenario. The injuries sustained by the seriously injured infant are considered unlikely to be ameliorated by the introduction of 16-g seats.

The high assessment assumes that the local g forces were too high for occupant survival even if restrained and that uncontained debris would still cause serious injuries. Impact forces must have been significant because of the general break-up of the aircraft structure. Therefore, no benefit would be gained from the introduction of 16-g seats.

The median assessment is taken as being between the high and the low assessments.

The high, median, and low predictions of the number of impact fatalities and injuries resulting from the use of 16-g seats are:

	<b>Minor or No Injuries</b>	<b>Serious Injuries</b>	<b>Fatal Injuries</b>
<b>High</b>	<b>1</b>	<b>17</b>	<b>11</b>
<b>Median</b>	<b>12</b>	<b>12</b>	<b>5</b>
<b>Low</b>	<b>23</b>	<b>6</b>	<b>0</b>

### Scenario 4

Since there was no fire in this accident, all serious and fatal injuries were as a result of blunt force trauma. Traumatic injuries included severe head injuries and chest injuries including transected aortas, cervical spinal fractures, basular skull fractures, hip fractures, and multiple lower leg fractures particularly at the ankles. In this scenario, for 16 seat assemblies, inboard seat rear legs remained attached to the floor track, the outboard legs were fractured at the floor track and the seats were found outside the cabin, indicating significant failures in seat structure. There was also a reported fracture of the longitudinal floor track beam, evidenced by a downward disruption of floor panels between two lateral floor beams. It is considered that the remaining seat assemblies (14 off) may have detached from the floor tracks due to this failure. Therefore, benefits were restricted to the 16 seat assemblies that were not associated with floor beam failure.

The low assessment is based on 16-g seats remaining undamaged and in place, restraining the occupants from injury caused by impact with separated seats. It is assessed that all serious and fatal injuries would be reduced to minor or no injuries. No benefit is likely to be achieved for those infants that sustained injuries.

The high assessment assumes that the local g forces were too high for occupant survival even if restrained and that uncontained debris would still cause serious injuries. Impact forces must have been significant because of the general break-up of the aircraft structure. Therefore, no benefit would be gained from the introduction of 16-g seats.

The median assessment is taken as the average of the high and the low assessments.

The high, median, and low predictions of the number of impact fatalities and injuries resulting from the use of 16-g seats are:

	<b>Minor or No Injuries</b>	<b>Serious Injuries</b>	<b>Fatal Injuries</b>
<b>High</b>	<b>1</b>	<b>45</b>	<b>45</b>
<b>Median</b>	<b>24</b>	<b>35</b>	<b>32</b>
<b>Low</b>	<b>46</b>	<b>25</b>	<b>20</b>

Scenario 5

In this scenario, most of the seats were found separated from their floor tracks and floor panels were displaced, along with the aft galley and lavatories. Damage to the inside of the cabin was extensive. The extensive damage in this scenario suggests that local deceleration forces were high and the assessments of benefit were consequently modest.

The low assessment is based on 16-g seats remaining undamaged and in place, restraining the occupants from injury (including head injuries). It is assumed that other causes of injury associated with the impact (e.g., wreckage debris, lack of limb restraint) would still have caused some injuries even if 16-g seats did not become detached or fail. It is therefore assessed that one-half of the fatal injuries and one-half of the adult serious injuries would be reduced to minor or no injuries.

The high assessment assumes that the displaced floor panels, indicative of the floor suffering significant bending and twisting, were sufficient to detach even 16-g seats, leading to little or no benefit. In addition, uncontained debris would still cause serious injuries.

The median assessment is taken as the average of the high and the low assessments.

The high, median, and low predictions of the number of impact fatalities and injuries resulting from the use of 16-g seats are:

	<b>Minor or No Injuries</b>	<b>Serious Injuries</b>	<b>Fatal Injuries</b>
<b>High</b>	<b>2</b>	<b>18</b>	<b>9</b>
<b>Median</b>	<b>9</b>	<b>14</b>	<b>6</b>
<b>Low</b>	<b>16</b>	<b>9</b>	<b>4</b>

## ACCIDENT REF: 19900214A

Date:	14-Feb-1990	Flight Phase:	Approach
Aircraft:	A320	Location:	Bangalore, India

### DESCRIPTION OF ACCIDENT

#### RESUME

On 14-Feb-1990 an Indian Airlines A320-231 registered as VT-EPN was approaching Bangalore Airport, India.

During the final approach, the aircraft descended below the normal approach path and its wheels contacted ground in a golf course area about 2300 feet short of the runway and impacted an embankment at the boundary of the golf course. The aircraft thereafter hopped over a ditch and a road adjacent to it and landed on an area outside the boundary wall of the airport. The aircraft was destroyed as a result of impact with ground and subsequent fire.

There were 7 crew and 139 passengers aboard. Both flight crewmembers, 2 flight attendants and 88 passengers suffered fatal injuries. One flight attendant and 21 passengers suffered serious injuries. Two flight attendants and 30 passengers escaped with minor or no injuries.

#### IMPACT

The aircraft initially touched softly on the golf course ground on its main wheels at a distance of approximately 2300 feet short of the beginning of the runway. The aircraft then bounced and remained in the air for about 230 feet and thereafter touched the ground on its main landing gear followed by its nose landing gear. At this stage, the right engine also touched a raised portion of ground. Immediately after this the aircraft hit an approximately 12-foot-high embankment leading to separation of both the engines, undercarriage damage, and extensive damage to the front fuselage. The aircraft wings had, on impact, cut off trees over the embankment. The aircraft in this condition hopped over an adjacent ditch and road covering a distance of approximately 26 feet and fell down in a grassy and rocky area approximately 150 feet from the airport boundary wall.

Breaks in the fuselage were large enough to facilitate escape for a few passengers.

The lower portion of front fuselage ahead of the wings was severely damaged by impact with the embankment. The rear fuselage behind the wings, however, remained in shape. On the right hand wing there were ruptures and openings on the front and rear spar near the root from where fuel leaked.

Severe longitudinal/circumferential crumpling was observed aft of the centre wing box. About 11 feet aft of the wing rear spar there was a fuselage fracture about 9 inches wide extending from

just above the window line to the lower belly on the left-hand side. On the right-hand side this was not observed.

The right-hand half of the cockpit shell remained with the front and side windscreens in position. The outer skin of the fuselage surrounding the windscreens did not show any evidence of wrinkling, crumpling, or cracks, particularly around the right-hand sliding window. Even on the inside the sliding window framework was firmly intact. The window handle appeared to be intact with the release button in the pressed position.

Main and nose landing gear structure sheared from their attachments and dragged forward along with the aircraft. Some portions of these components fell in the trail of the wreckage. Bogey beam of both the main undercarriages along with supporting structure suffered extensive damage. The nose wheel strut and its supporting structure disintegrated.

Due to openings in the starboard wing spar, all the fuel had leaked away and this fuel mainly supported the fire. However, in the port wing tank fuel was still present and approximately 200 litres were retrieved. It appeared that the fuel contained in the port wing did not support the fire.

#### FIRE

As the aircraft came to rest a huge fire engulfed the forward fuselage. There was extensive fire in the front fuselage area ahead of the wings and practically the whole of the fuselage along with other structure were consumed by fire. Few half burnt and damaged portions of fuselage containing forward doors, forward cargo hold door, and right side wing shields were left. The centre fuel tank was open from the forward end and suffered extensive fire damage. Due to the deceleration at impact, the fuel in the tank would have moved forward through the ruptures of the tanks and spread all over the inside bottom portion of the front fuselage. After the aircraft came to a stop, fuel would spill onto the ground. There were a large number of stones in the area where the aircraft came to rest. Rubbing of the structure of the fuselage against these stones could easily cause a spark to start the fuel fire.

One survivor, who occupied seat 12C, stated that he saw the fire coming out of the cabin floor near row 10 or 11. This area would be near the leading edge of the wing root. Another survivor witness, who was sitting in 21A, stated that he saw fire leaping out near the 17th row, right side. This area would be close to the aft end of the wing root.

Seats, cabin floor, and galley equipment in the front fuselage were totally consumed by fire. However, in the middle and rear fuselage to where the fire spread from the front side, most of the seats and flooring were burnt.

The top portion of the fuselage shell up to window level was consumed by fire. The rear galley equipment was also exposed to severe cabin fire.

In the tail, both the rear doors and galley, though exposed to cabin fire, were externally in better condition.



With the comparatively low amount of fuel that was available it was rather difficult to explain how the rear passenger cabin was fully burnt up to the rear galley. In all probability, the impact with the embankment and the passage of the fuselage over and rubbing against the embankment may have caused a serious rupture to the bottom surface of the fuel tanks, including the wing tanks. This would have started spilling fuel when the aircraft came onto the ground on its belly and slid forward to come to a stop. Such fuel might have contributed to the damage caused to the floor structure and burning of all internal furnishings. The intense fire due to the fuel may have lasted for a very short period of time which was subsequently supported by the furnishings.

Both front and rear cargo doors were found closed. The front door was partially burnt and damaged. The nature of the burns clearly indicated that the fire was initially outside the cargo hold on the cabin side and fire had travelled from the cabin to the cargo hold.

The fire rescue crew did not have a key to open the only gate in the airport perimeter fence near the accident site. As a result time was lost in cutting open the lock and in pushing open the rusty gate. The rescue vehicles could only approach the site at walking speed due to the poor state of the road and terrain. As per eyewitness reports, the Crash Fire Tenders had reached the crash site 10-20 minutes after the occurrence of the accident.

The elderly Rapid Intervention Vehicle had regular starting trouble and was the last vehicle to reach the site of the crash. The fire was extinguished after about 40 minutes when the city fire brigade had also reached the site.

Inspection of the wreckage revealed a hole in the forward spar apparently caused by some force from inside the right wing tank indicative of a postcrash explosion from inside the tank.

#### EVACUATION

The occupants consisted of a pilot-in-command, co-pilot, 5 cabin crew, and 139 passengers. The cabin interior was configured to seat 168 passengers.

At the time of commencement of approach No Smoking and Fasten Seat Belt signs were illuminated.

The usual landing announcement was made by an air hostess who, along with another air hostess, also checked the passengers seat belts when the Seat Belt sign had been switched on. When the pilot announced, "cabin crew to your stations," the cabin crew had positioned themselves in their respective seats.

As the aircraft hit the embankment, one air hostess was thrown out of her seat onto the cabin floor. One, who was sitting near the R/H toilet, hit her head against the toilet wall and was injured. Another one was alert to the situation and as soon as the aircraft came to a stop she opened the left-hand rear door.

According to the statements of some of the survivors, the aircraft made a rough landing and thud noise was heard three times before the aircraft came to a stop.

An eye witness had seen the aircraft coming to its final rest position and had seen someone thumping against the right-hand cockpit window, whom he thought to be a pilot, before fire engulfed the aircraft.

Upon impacts, many people had impacted the seats in front of them causing various injuries, dizziness, and shocks. Some seats in middle to forward section of the cabin had also broken.

Immediately thereafter, smoke started emanating from the front portion of the cabin of the aircraft. One emergency window reportedly opened by itself, and some passengers egressed through that emergency window on their own. However, smoke and heat started spreading backwards inside the cabin. After opening the rear left-hand door, two air hostesses shouted at the passengers to leave the aircraft immediately, since the smoke starting from the front of the cabin was spreading fast towards the rear.

According to two air hostesses, the passengers were slow in reacting to their announcement, probably due to shock or injuries. They had to help some passengers to exit out of the aircraft. Some passengers also helped other passengers to come out of the aircraft.

The two air hostesses then went up in the cabin to help other passengers, but due to thick smoke, they found it difficult to breathe and thus, had to return and leave the aircraft.

While leaving the aircraft, they saw an air hostess with injuries on her face and in a dazed condition sitting near right-hand toilet. They helped her exit out of the aircraft.

Upon seeing and hearing about the aircraft crash, a number of people from the surrounding areas had rushed to the spot. Passers-by on the road going round the crash site had also stopped on seeing the aircraft on fire.

Some passengers were seen coming out, in inverted position with head first from underneath the damaged nose portion. They were helped by local people who pulled them out of the wreckage. One person while trying to come out from there was caught up by the fire and was seen dying there.

After coming out of the aircraft, the passengers landed onto marshy area from where they went away to the nearby road. From there the injured passengers were taken to the hospitals.

One passenger after coming out of the aircraft was physically helped by an air hostess to the vehicle for removal to the hospital.

There were some minor explosions, because of which, most of the people gathered around the crashed aircraft, kept themselves at a safe distance from the aircraft.

However, some persons, undaunted by the fire, went inside the cabin from rear left-hand door and pulled out the injured passengers until they were prevented by smoke and suffocation.

The passengers seated in 3E and 4D survived. Similarly passengers seated in 7C, 7D, 7F, 8D, and 8F survived. From witness statements it did appear that an opening may have been created by either the crash or the explosion somewhere around that area for them to escape the fire.

From rows 11, 12, and 13, all 9 passengers who were seated on the left side of the aisle survived and one who was seated at 11D also survived. Six passengers seated on the right side in these rows all died. It was known that the left-hand side emergency exits were opened and these 10 people would have survived coming out of those exits. It was thought most probable that either the right-hand emergency exits were not opened by the passengers sitting next to them or they were burnt after exiting the aircraft, as intense fire had been observed on the right-hand side wing root area. Also, from the postmortem report it was observed that the passenger seated at 12F had injuries to his forearms, hands, and abdomen. It was therefore possible that he was incapable of opening the exit next to him before being burnt to death.

The officer-in-charge of fire services had reached the site 8-9 minutes after the crash. On reaching the site he reportedly opened the rear right-hand door of the aircraft from outside. But, by that time, there was no one to come out of the aircraft. He then went around the aircraft and helped 5-6 injured persons lying behind the left wing, near the burning fuselage of the aircraft, to be removed to safe place and then transported to the hospital.

Both the forward doors on port and starboard sides were found closed. Both the rear doors were open. The port side rear door was opened from inside, but the starboard side rear door was opened from outside by rescuers. The escape slide for the rear port door was lying detached from the door in uninflated condition. As the rear starboard door was opened from outside, it had not deployed the escape slide.

Only three out of the four overwing emergency exit windows could be found. The handle positions of two of them suggest that they were probably pulled. The other one was extensively burnt and no indications were available regarding position of handle.

The port overwing escape slide appears to have been deployed but later probably deflated due to fire burns. The starboard overwing escape slide was found packed and partially burnt inside the fuselage indicating that it was not deployed.

It was not possible to know the duration during which the aircraft was burnt and the time that was available to passengers inside the aircraft to escape. From the intensity of the fire the occupants of the forward seats had just a few seconds before the fire engulfed them. As 10 passengers had escaped through the left-hand overwing exits, assuming that 5 of them got out through each exit, it was roughly estimated that fire would have engulfed this region in about 1 minute or slightly less from the time of the third impact.

## AIRCRAFT FACTORS

The aircraft was an A320-231 registered as VT-EPN and operated by Indian Airlines.

The cabin was configured with 168 passenger seats.

The aircraft bearing serial number 079 was rolled out by Airbus Industries, France, on the 4th Quarter of 1989. The aircraft was issued Export Certificate of Airworthiness number 15279 dated 22-Dec-1989 by the DGAC, France. The aircraft arrived in India on 24-Dec-1989, and a Certificate of Airworthiness number 1941 was issued to it on 26-Dec-1989 by the Directorate General of Civil Aviation, India, in the normal category for Public Transport and for carriage of passengers, mail, and goods. The Certificate of Airworthiness was valid up to 21-Dec-1990.

The aircraft was fitted with two exits at the front and two at the rear of the passenger cabin. There were two overwing emergency exits above each wing.

## ENVIRONMENTAL CONDITIONS

The accident occurred at 13:03 hours Indian Standard Time in daylight.

The prevailing weather conditions at the time of the accident were reported to be: wind variable about 5 kt, visibility 10 km, cloud 3/8 at 2000 ft, and temperature 28°C.

## INJURIES TO OCCUPANTS

Of the 7 crew and 139 passengers aboard, 4 crew and 86 passengers died in the cabin fire. Two passengers later succumbed to their injuries in the hospital. One flight attendant and 21 passengers suffered serious injuries. Two flight attendants and 30 passengers escaped with minor or no injuries.

Postmortem examination of the captain showed that he had died of burns and the consequential shock. There were no fractures of any bones.

The autopsy of the copilot showed that the cause of death was due to burns sustained.

Analysis of the injuries suffered by survivors indicated that 8 persons had burn injuries; 26 persons had face, neck, and head injuries; 8 persons had nasal bone injuries; and 16 persons had fractures in other parts of the body. Many cases had multiple abrasions, lacerations, etc.

Of the 90 occupants that died at the accident site, cause of death for 81 was established as shock due to burns sustained. Only in nine cases were burns not mentioned in the autopsy reports and possibly the burns may have been postmortem. (But almost all these were stated to be allotted seats in rows 2, 3, 5, and 6.)

In 13 individuals only, was there evidence of severe injuries with shock present. This would indicate that four of these had sustained both severe injuries with shock as well as burns.

It was seen that 32 persons sustained injuries to lower limbs, 20 sustained injuries to the head, and 7 sustained thoracic injuries. It was thought highly probable that at least some of these had died of burns because of physical inability to escape quickly.

It is evident from the seating pattern that most of the fatalities had occurred in passengers occupying the first 10 rows, rows 17 to 20, the cockpit crew, and the 2 flight attendants occupying the forward seats. Passengers in the vicinity of the emergency exits and those near the rear door generally managed to escape.

It seemed possible from the injury analysis that the occupants of seats 8A and 8B sustained injuries due to a hard object like a briefcase hitting the head/shoulder.

All occupants of the left side at rows 5 and 6 had sustained multiple injuries including head injury, indicating the possibility of some forces causing severe damage in this area or causing failure of these seats.

Twenty-four bodies showed injuries to leg/ankle. The possible cause of such injuries could have been the flailing of legs at the time of impact, hitting against the bottom bar of the seat ahead. These injuries may have prevented some of these passengers from exiting the aircraft in time.

A large number of fatalities and survivors had face, neck, and head injuries. It was thought possible that quite a few of these may have been due to passengers hitting their face/head against the back of the seat in front of them. Such injuries could have been possible if the passenger does not tie the seat belt snugly or the seat in front is not kept in the vertical position prior to landing.

### **ACCIDENT SCENARIOS AND SURVIVABILITY CHAINS**

This accident is considered as having seven scenarios, as shown in figure A-8.

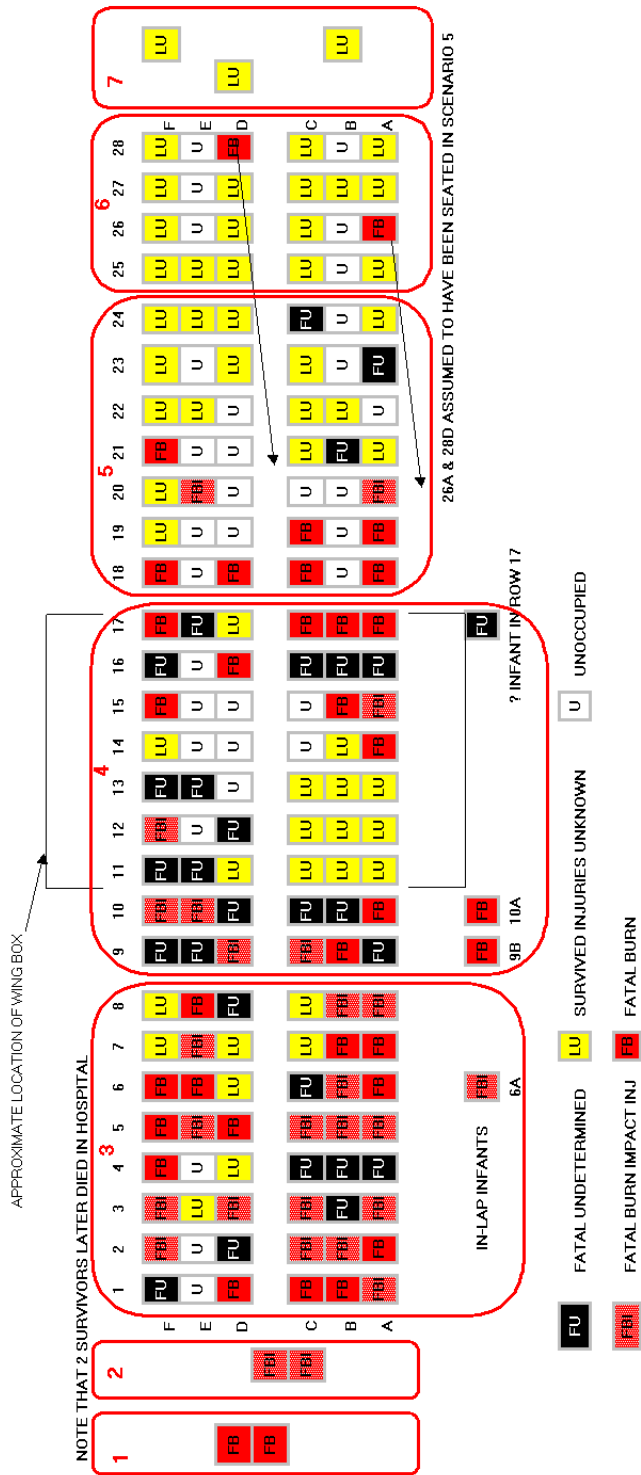
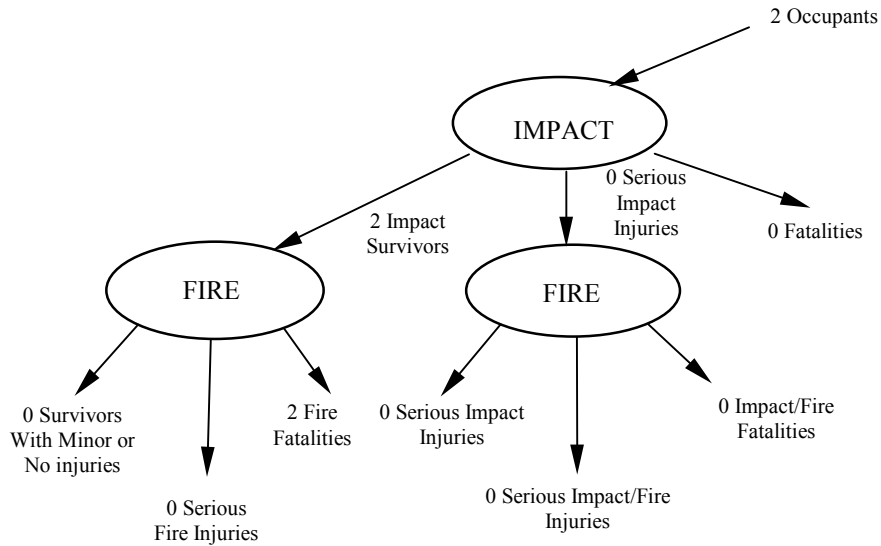

FIGURE A-8. LOCATION OF INJURIES AND SCENARIOS

**Scenario 1** represents the cockpit area containing two flight crewmembers, who suffered fatal injuries due to the fire.



SCENARIO 1

**Scenario 2** represents the forward vestibule area containing two cabin crewmembers, who suffered fatal injuries due to impact and the fire.

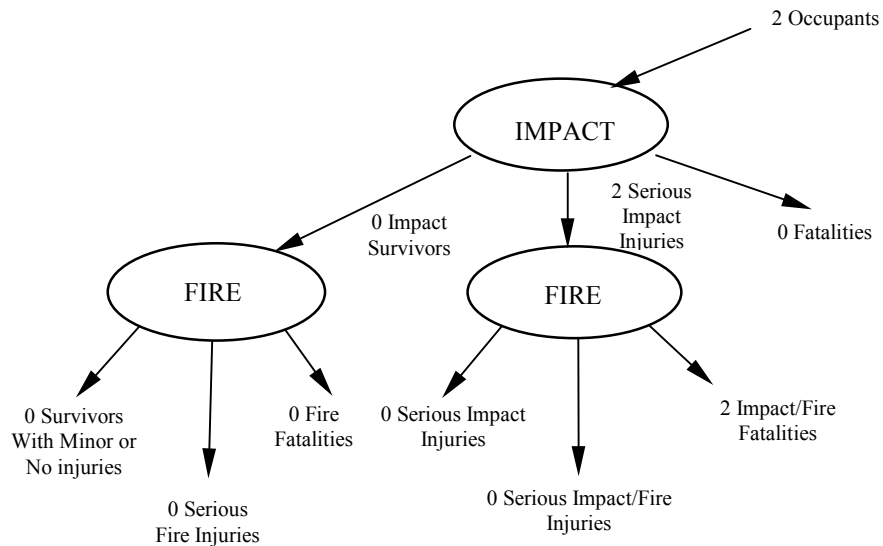

SCENARIO 2

**Scenario 3** represents passenger seat rows 1 through 8, containing 46 passengers.

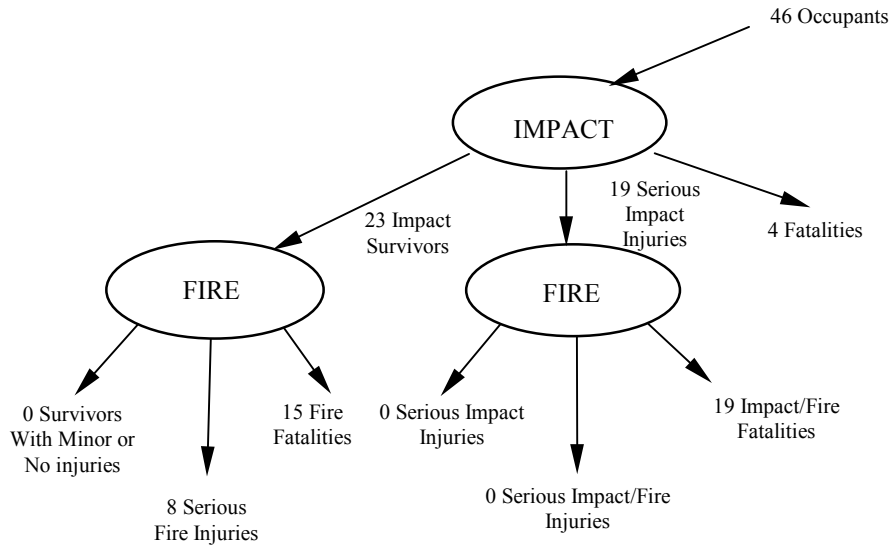

**SCENARIO 3**

**Scenario 4** represents passenger seat rows 9 through 17, containing 48 passengers.

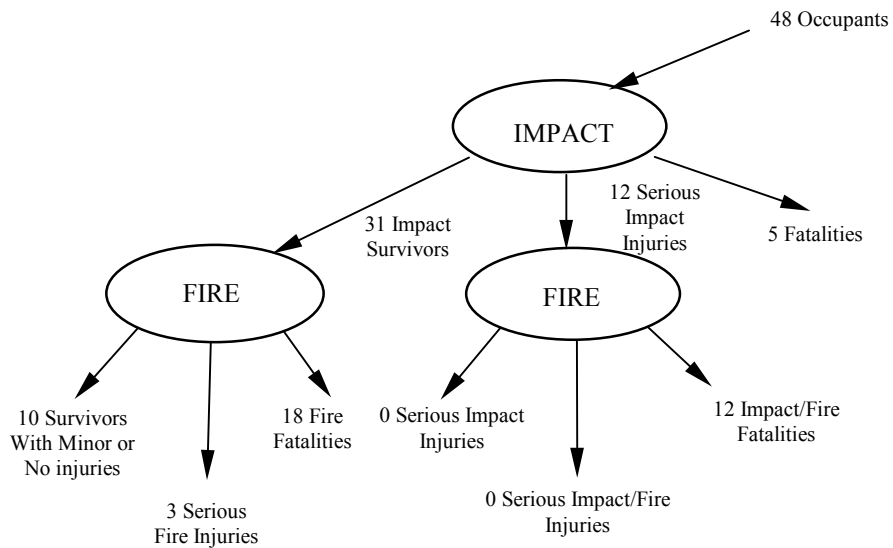

**SCENARIO 4**



**Scenario 5** represents passenger seat rows 18 through 24, containing 29 passengers.

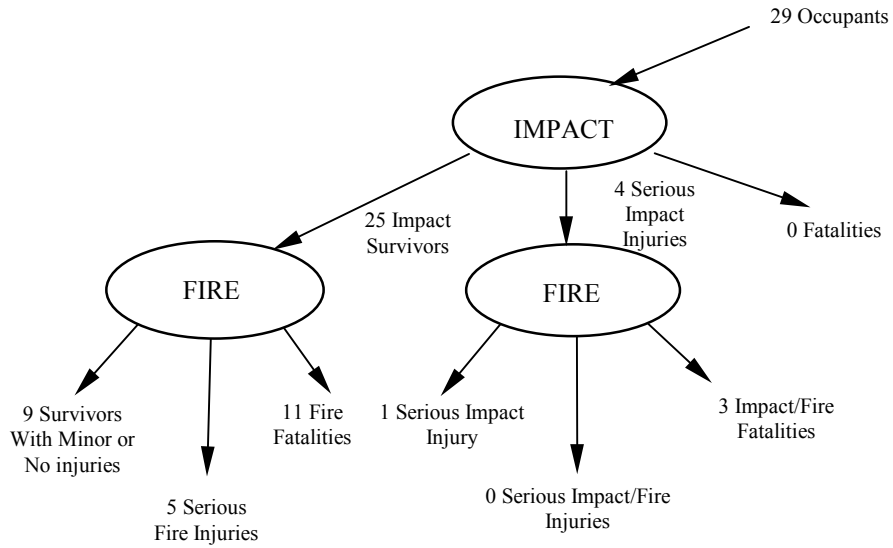

**SCENARIO 5**

**Scenario 6** represents passenger seat rows 25 through 28, containing 16 passengers.

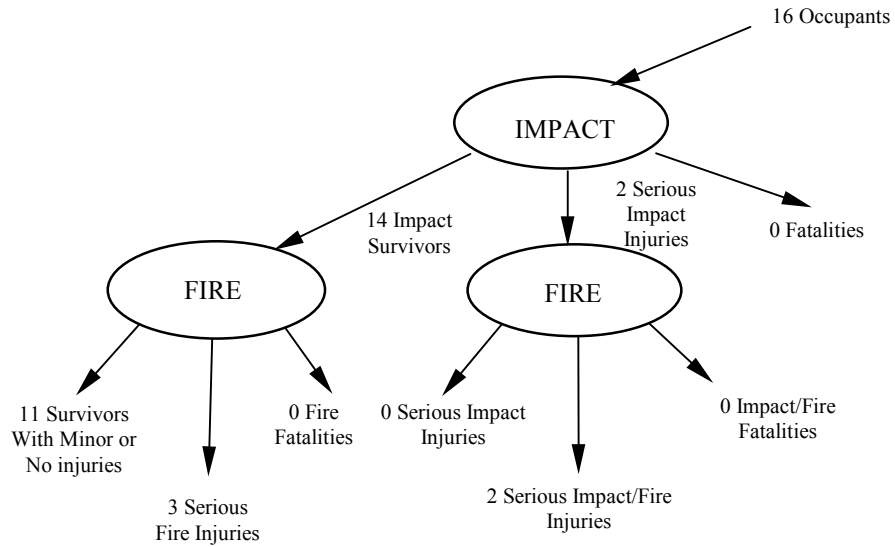

**SCENARIO 6**

**Scenario 7** represents the rear cabin crewmember area containing three cabin crew, one of which suffered serious injuries when hitting her head after being thrown out of her seat.

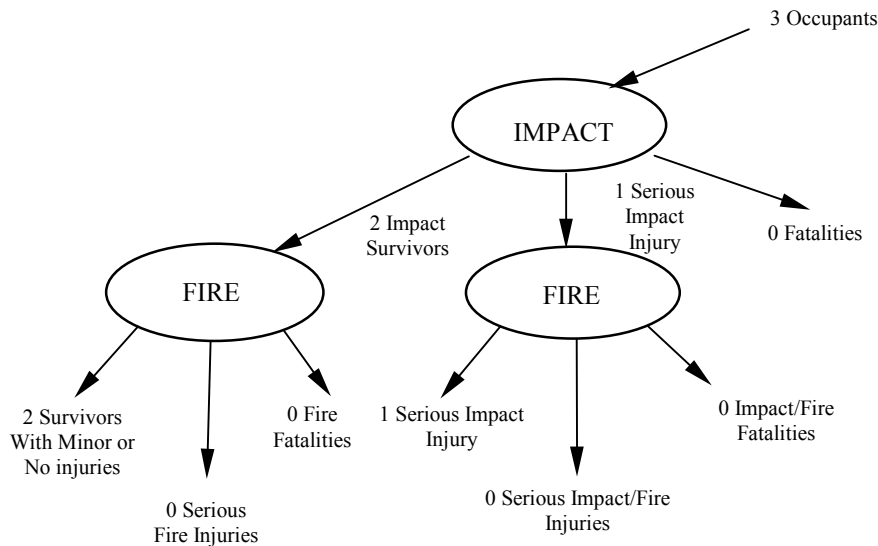

SCENARIO 7

**EFFECT OF INTRODUCING 16-g SEATS**

Scenario 1

This scenario contains only flight crew seats and therefore benefit from the introduction of 16-g passenger seats is not applicable.

Scenario 2

This scenario contains only cabin crew seats and therefore benefit from the introduction of 16-g passenger seats is not applicable.

Scenario 3

It was reported that seats in the middle to forward section had broken and that head and limb injuries were sustained. On this basis, it is considered feasible that all four fatal injuries may have been avoided had 16-g seats been fitted. The median assessment of number of impact fatalities is therefore taken as zero.

The high assessment is based on there being no improvement in impact injuries had 16-g seats been fitted and the low assessment assumes that all impact injuries would have been avoided. The median level of serious injuries is taken as being between the high and the low.

The aircraft was reported to have been fitted with low heat release cabin materials.

The high, median, and low predictions of the number of impact fatalities and injuries resulting from the use of 16-g seats are:

	<b>Minor or No Injuries</b>	<b>Serious Injuries</b>	<b>Fatal Injuries</b>
<b>High</b>	<b>23</b>	<b>19</b>	<b>4</b>
<b>Median</b>	<b>37</b>	<b>9</b>	<b>0</b>
<b>Low</b>	<b>46</b>	<b>0</b>	<b>0</b>

#### Scenario 4

It was reported that seats in the middle to forward section had broken and that head and limb injuries were sustained. The assessments are based on a similar rationale to that used in scenario 3.

The aircraft was reported to have been fitted with low heat release cabin materials.

The high, median, and low predictions of the number of impact fatalities and injuries resulting from the use of 16-g seats are:

	<b>Minor/No Injuries</b>	<b>Serious Injuries</b>	<b>Fatal Injuries</b>
<b>High</b>	<b>31</b>	<b>12</b>	<b>5</b>
<b>Median</b>	<b>42</b>	<b>6</b>	<b>0</b>
<b>Low</b>	<b>48</b>	<b>0</b>	<b>0</b>

#### Scenarios 5 and 6

From a study of the reported injuries to persons in these scenarios, it is considered that 16-g seats would not have ameliorated the extent of their injuries.

#### Scenario 7

This scenario contains only cabin crew seats and therefore benefit from the introduction of 16-g passenger seats is not applicable.

## ACCIDENT REF: 19901203A

Date:	03-Dec-1990	Flight Phase:	Taxi
Aircraft:	DC9	Location:	Romulus

### DESCRIPTION OF ACCIDENT

#### RESUME

On 3-Dec-1990 a Northwest Airlines DC-9-14 registered as N3313L had just taxied onto the active runway at Detroit Metropolitan/Wayne County Airport, Romulus, Michigan in dense fog when it was hit by a B727 on its takeoff roll.

The DC-9 was destroyed by the impact and a subsequent fire.

Contributing to the fatalities in the accident was the inoperability of the internal tail cone release mechanism which trapped occupants in a cabin fire.

Contributing to the number and severity of injuries was the failure of the crew to properly execute the passenger evacuation.

There were 4 crew and 40 passengers on board. One crewmember and seven passengers suffered fatal injuries. Ten passengers suffered serious injuries. Three crew and 23 passengers suffered minor or no injuries.

#### IMPACT

Visibility was deteriorating as the aircraft began to taxi, but the flight crew were able to follow the yellow line floor markings. As the visibility worsened the crew became less sure of their position. The captain stopped the aircraft and could just see the beginning of a white line. The aircraft had inadvertently taxied onto the active runway. The captain was informing ground control that he was lost and saw the B727 coming right at them.

The right wing of the B727 penetrated the right side of the DC-9 fuselage cutting into the flight deck and forward service door. It then sliced the length of the cabin ejecting fuel from the damaged wing tip.

The aircraft's fuselage was cut in a straight line just below the bottom of the windows on the right side. The cut line remained along the right side of the fuselage.

The first contact occurred when the wing tip struck just below the first officer's middle window. The first officer stated that he instinctively ducked over to the left as the B727 wing tip grazed his side of the cockpit.

As the B727 passed the DC-9, the DC-9 fuselage began tearing and simultaneously the wing tip of the B727 began to disintegrate. As the wing tore through the fuselage, the outboard mid-canoe fairing of the inboard flap on the underside of the B727 right wing came in contact with the right wing leading edge of the DC-9. About the same time, the B727 right main landing gear door impacted the right wing tip of the DC-9. The DC-9 wing tip was sheared off and a portion of it remained lodged in the B727 gear door.

The B727 right wing continued to cut through the right side of the DC-9 fuselage until its No. 8 leading edge slat came into contact with the right engine cowl of the DC-9. The right wing of the B727 then sheared off at the 13.5 foot point as it came in full contact with the right engine of the DC-9, which then separated from its pylon.

Following the collision, the captain shut off the fuel control levers.

Many of the seat frames on the right side of the cabin were displaced rearward from their normal position.

#### FIRE

As the right wing of the B727 sliced through the DC-9 fuselage it ejected fuel from the damaged wing tip. The fuel vent surge tank was probably ruptured. On hitting the right hand engine of the DC-9 the No. 3 (outboard) fuel tank was ruptured and a fireball erupted from the rear of the aircraft and fire traversed forward throughout the cabin.

The passenger in seat 11D stated that flames erupted almost immediately. The passenger in seat 6B said that after the impact he saw a flame that looked like a blow torch coming into the cabin at the right rear. The passenger in seat 15A saw flames along the right side of the fuselage immediately after impact.

The interior of the passenger cabin was extensively damaged by the fire. All cabin sidewall and ceiling panels, stowage bins, and seat cushions, except for some small pieces, were destroyed by fire. The remains of double-seat frames from about their bottom seat pans to the floor were intact and in place from the left overwing hatch to the aft lavatory. All other seat frames were generally not as intact and had more fire damage.

The fuselage structure above the cut line, on the right side, to the top was destroyed by fire. The majority of the fuselage was burned from just aft of the cockpit to just forward of the aft bulkhead and from the top to just above the window line on the left side.

The accessory compartment between the aft pressure bulkhead and the fibreglass tailcone contained considerable amounts of soot. Plastic electrical wiring support loops and insulation on some small wires in that area had melted. The thermal insulation on the aft side of the pressure bulkhead was not fire damaged.

The fire department responded with five vehicles that had difficulty finding the burning aircraft because of thick fog. Arriving units extinguished fires located at the separated No. 2 engine. Following this effort, an interior attack was attempted on the left side of the aircraft using hand lines and bumper turrets through the cabin window openings. This attack was abandoned because of the intensity of the fire. A short time later, fire breached the roof of the cabin and overhead turrets applied foam into the fuselage. It was estimated that the fire was extinguished about 3 minutes after the vehicles arrived.

## EVACUATION

There were 2 flight crew, 2 cabin crew, and 40 passengers aboard.

After shutting off the fuel control levers, the captain of the DC-9 announced three times on the public address (PA) system to evacuate the aircraft. As he looked to the rear of the aircraft while replacing the handset, he saw people blocking the cockpit doorway while trying to exit the aircraft. He stated that he heard a woman scream that the door was jammed. He exited through his sliding window and used the escape rope so that he could open the door from the ground. He discovered that the L1 passenger entry door was open and believed that the woman was referring to the R1 galley door as the one that was jammed. He then assisted passengers in moving away from the aircraft and escorted one passenger to a parked police car.

The first officer said he thought to conduct the evacuation checklist following the collision but only remembered pulling the engine fire shutoff switches. After extricating his injured right leg from the area between the control column and the deformed instrument panel, he entered the cabin and saw five or six people standing at the L1 door. He pushed one passenger out the door and the others followed. He then exited through the L1 door and later inflated the emergency evacuation slide from the ground. After assisting a passenger off the wing, he attempted to climb up the slide to re-enter the aircraft but fell down and was subsequently restrained by a fireman.

Passengers evacuated the aircraft through the L1 and R1 doors and the left overwing exit. The lead flight attendant, the first officer, and two off-duty flight attendants exited through the L1 door also. None of the crewmembers inflated the L1 evacuation slide prior to exiting the aircraft. The captain used his escape rope and evacuated through the left cockpit window. The right overwing exit was not used. One passenger and the flight attendant assigned to the aft jump seat entered the tailcone but they were unable to deploy the tailcone exit and did not survive the accident.

The lead flight attendant stated that she had left her jump seat to secure the galley and was standing in the cockpit doorway when the impact occurred. She dropped to the floor, and when she stood up and turned around, people were rushing to the front of the aircraft. A woman fell at her feet and, after she helped her up, the flight attendant opened the L1 door. She stated that the escape slide pack had fallen off the door, and she bent down and pushed the slide through the door with her left hand while opening the door with her right hand. When the door was open about 2 feet, she jumped out of the aircraft to get out of the way. She shouted commands from the ground for passengers to jump out of the aircraft. She stated that she looked for the slide's

inflation handle but could not find it. She testified that if she had found the handle while she was still in the cabin, she would have inflated the slide even though the door was not completely opened.

A passenger seated in 6D stated that following the collision he reached the L1 exit and saw a uniformed flight attendant standing at the door trying to open it. The passenger said that the flight attendant could not lift the handle and he and another man told her that they would open it. He stated that she bent down to the floor and said something like, "I'm going to pull the chute." When the door was open about 1.5 to 2 feet, the other man jumped out and the passenger sat on the door sill and pushed the door open further with his feet. When the door was about halfway open he pushed himself off the door sill and jumped to the ground.

An off-duty flight attendant who had been seated in seat 1D saw that the woman in 2D had a head injury and was not attempting to exit. She assisted that woman to the L1 exit. The door was partially open, and she thought that the first officer pushed the door open. She assumed that the slide had malfunctioned because the lead flight attendant was on the ground and did not attempt to inflate it. She said that in order to minimize the risk to the passengers who were jumping from the door in a "crazy" manner, she held onto the door with her right hand and lowered passengers to the ground with her left arm. Her only injuries were muscle strain as a result of lowering passengers to the ground. After she exited the aircraft, she placed three injured passengers in a sheriff's patrol car. When she could not find the operator of the vehicle, she commandeered it to move the injured passengers away from the burning aircraft. She did not see ambulances, so she urged the police to transport the three passengers to the hospital.

The left overwing exit was opened by the passenger in seat 13B. The passengers in seats 9D and 10A initially headed for the forward exits and then turned around and exited through the left overwing exit. The passenger in seat 7D joined the crowd that was surging forward but then turned around and exited through the left overwing exit also. The passenger in seat 6B said he went back toward the overwing exit and used it because he did not want to "wait in line."

The tailcone exit was not opened during the evacuation. The external tailcone release was not activated by any flight crewmember or rescue personnel. The internal tailcone release mechanism was later found to have been mechanically inoperable. A flight attendant and a passenger from 15D succumbed to smoke inhalation in the tailcone.

The L1 door could not be closed later because of interference between the upper aft corner of the door and the door fuselage jamb. The door's operating handle could not be rotated to its fully closed position.

The L1 evacuation slide cover was found inside the cabin near the L1 exit lying loosely on top of the wadded up R1 slide, with no fire or smoke damage. Black shoe prints were found on the aft side of the cover consistent with a passenger statement that he pushed the door open with his feet while sitting on the door sill. The L1 evacuation slide was deflated and found wadded up on the cabin floor next to the L1 exit. The girt bar was found installed in its floor fittings. The slide's manual inflation handle was twisted inside the girt skirt. When the slide was unfolded by

investigators, the manual inflation handle was still attached to the top of the girt in its stowed position.

The R1 galley service door was found in three pieces on the cabin floor. The R1 slide cover was found undamaged on top of the wadded up L1 slide. The R1 girt bar and its floor fittings were not damaged; however, foreign material was found inside the aft floor fitting. The R1 slide was not inflated and the girt end of the slide was in the girt sleeve in its proper position. The slide cover latch and cable assembly were properly installed around the girt bar in the centre girt skirt cutout. The entire right side of the valise was missing and the edges of the slide were charred.

#### AIRCRAFT FACTORS

The aircraft was a DC-9-14 registered as N3313L and operated by Northwest Airlines.

The cabin was fitted with a passenger entry door at the front on the port side and a service door opposite. There was an overwing emergency exit above each wing. The rear of the fuselage was fitted with a tailcone exit door and ramp.

#### ENVIRONMENTAL CONDITIONS

The accident occurred during daylight with a wind of 110° at 11 kts and visibility of 0.25 miles in fog. The ambient temperature was 8°C.

#### INJURIES TO OCCUPANTS

There were 4 crew and 40 passengers on board. One flight attendant and seven passengers suffered fatal injuries. Ten passengers suffered serious injuries. Three crew and 23 passengers suffered minor or no injuries.

The flight attendant was found face down on the tailcone catwalk with her head directly under the tailcone release handle and a male passenger from 15D, who had sustained a minor head injury, was found aft of the tailcone slide pack with his buttocks resting partially on the tailcone access panel and his upper torso near the tailcone's lower right latching mechanism. Both victims died of asphyxia secondary to smoke and soot inhalation and both were within reach of the tailcone emergency release handle.

Three male passengers who occupied seats 7F, 9F, and 12F were the only persons to die from massive blunt force trauma.

A female passenger seated in 6F and a male passenger originally seated in 12D died of asphyxia secondary to smoke and soot inhalation. The male was found in the aisle at row 11 and both of these victims were severely burned.

A male passenger assigned to seat 10D, who was found in the aisle at row 9, died of thermal injuries; no traumatic injuries or smoke and soot inhalation were detected.



## ACCIDENT SCENARIOS AND SURVIVABILITY CHAINS

Details of seat location and injuries were available for only some of the occupants; therefore this accident was considered as a single scenario encompassing the whole cabin.

It has been assumed that the 10 serious injuries were due to the ensuing fire because the only impact forces came directly from the B727's wing penetrating the fuselage, causing impact fatalities.

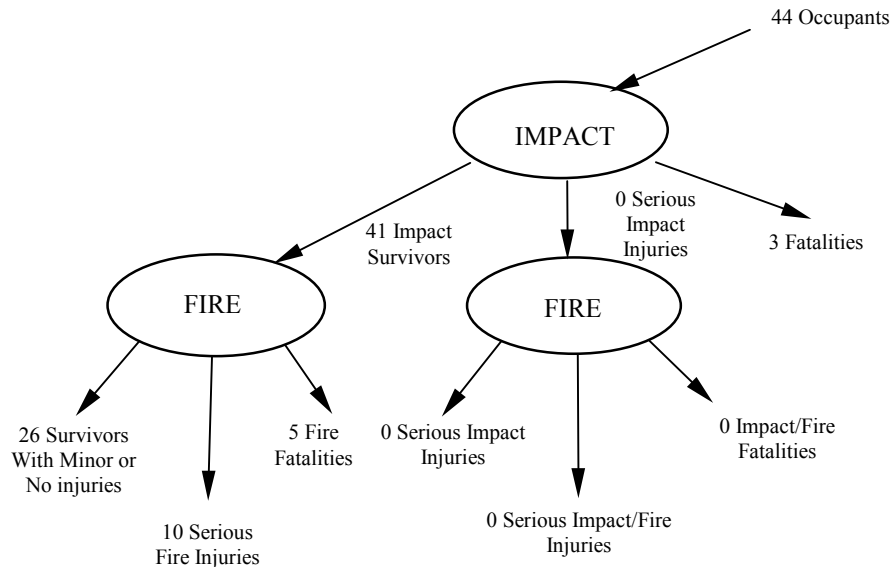

## EFFECT OF INTRODUCING 16-g SEATS

This accident happened while the aircraft was taxiing and the impact forces came from another aircraft wing which penetrated the fuselage. There was no conventional longitudinal deceleration, which normally characterises an impact-related accident and is part of the design criteria for 16-g seats. Therefore, it is assessed that the introduction of 16-g seats would not have provided any benefit in this accident.

## ACCIDENT REF: 19910201A

Date:	01-Feb-1991	Flight Phase:	Takeoff
Aircraft:	B737	Location:	Los Angeles

### DESCRIPTION OF ACCIDENT

#### RESUME

On 1-Feb-1991 a Boeing 737-300 registered as N388US was landing at Los Angeles International Airport. It collided with a Fairchild Metroliner that was positioned on the same runway awaiting clearance for takeoff.

The aircraft slid to the left side of the runway and into an unoccupied fire station whereupon a fire broke out. An evacuation took place but 20 passengers and 2 crewmembers were fatally injured.

#### IMPACT

The B-737 remained largely intact as a result of the collision with the Metroliner. The aircraft veered off the runway and into an unoccupied fire station building.

The only parts of the B-737 that separated from the aircraft were the nose cone, nose gear doors, and left pitot tube. The impact with the building destroyed the cockpit and damaged the left engine and an area of the left wing leading edge. The top and left sides of the cockpit were crushed inward, and the forward section of the cockpit on the captain's side was crushed in, down, and to the right. Both forward cockpit windshields were cracked. Several propeller slashes were on the lower right side of the B-737 fuselage skin in the area of the forward galley door.

No fuel tank rupture or leakage from the wing or centre tanks of the B-737 was observed. The fuel which was on fire came from the ruptured fuel cells of the Metroliner which was found crushed underneath the B-737.

Several passengers noted that the landing appeared to be routine; however, within a few seconds of touchdown they recalled feeling the aeroplane, move up and down, consistent with heavy brake applications. They noticed an orange glow through the cabin windows on both sides of the aeroplane; flight attendants were heard yelling repeated commands "get down, stay down." After the impact with the building, the flight attendants commanded the passengers to release their seatbelts. The two rear flight attendants and several passengers had unbuckled their seatbelts after the first impact and were thrown forward when the aeroplane struck the building.

The R1 flight attendant stated that the "touchdown felt normal" and that shortly thereafter "I heard a big metal scrape, and felt like they slammed the brakes real hard." Within 2 or 3

seconds, the emergency lights came on and he began to shout commands, “grab ankles, heads down, stay down.” He saw the floor in front of him moving up and down about knee high.

## FIRE

After the first impact and while the aeroplane was still moving, the R1 flight attendant noted that the cabin became “really warm,” and he observed smoke coming from underneath the floor in front of him. He also remembered seeing smoke and fire on top of the valet closet in front of him. He described the smoke as “very thick.”

On the right side of the fuselage there were a number of small holes burnt through in the lower quadrant and a large hole had burnt through in the lower belly area.

In the forward cargo compartment, the cargo liner on the left side had very little heat damage whereas the right forward corner had heavy fire damage. There was slight fire damage to the cargo liners, the cabin floor, cargo compartment floor, and some structure in the area. This area also housed the crew oxygen cylinder, which was found loose. The cylinder contained heavy amounts of soot, except for the area of an attaching strap. The pressure gauge and regulator were extensively fire damaged, and the overpressure and supply lines were broken.

The firefighters were able to control the fire under the aircraft but fire continued in the cabin.

An area of the top of the B-737’s fuselage burnt through in the forward cabin between the first class and coach sections. This burnthrough was from the inside out. Interior fire damage in this area was extensive.

The top of the fuselage was also burned away from just aft of the wing to the aft doors. The fuselage along the floor beams was still attached aft of the wing so eventually the entire tail section drooped to the ground. At this time the firefighters were able to advance into the cabin and extinguish all remaining fires.

The forward passenger door (L1) was jammed shut, and the lower half of the door was displaced inward approximately 6 inches. There was no fire damage to the exterior of the door. The forward service door (R1) was open. The door was structurally intact, but its interior had sustained significant fire and heat damage. The exterior of the door contained soot near its bottom forward side. The aft passenger door (L3) was open, and both sides of the door were fire damaged. The aft service door (R3) was open. There was no soot on the interior surface of the door, and minor amounts of soot were evident on the exterior.

The most extensive interior fire damage was in the rear of the cabin. All interior materials located at 4 feet or higher were destroyed by the interior fire. The carpet was intact throughout the cabin with the exception of the first class section. The cabin seats contained fire-blocking material with Poly-Benzol Iomedizal (PBI). Floor proximity emergency lights were installed in the cabin and based on survivor’s statements they functioned during the evacuation. All of the overhead baggage compartments were found detached and melted onto the seats.

## EVACUATION

There were 2 flight crew, 4 cabin crew, and 83 passengers aboard. The cabin layout had 128 passenger seats.

As the aeroplane struck the abandoned fire station and stopped, the R1 flight attendant departed his jumpseat and went to his exit door. After assessing the area outside the door for fire, he rotated the handle to the open position and attempted to open the door. During this time he said that the smoke got so bad that he could no longer see anything. After forcing the door, he was able to open it about 12 inches and shortly thereafter he was able to open it fully. At that point, a passenger was standing by the door, and he pushed the passenger out of the aeroplane. The distance from the door sill to the ground was about 5 feet. Another passenger then passed the R1 flight attendant and jumped out. The flight attendant then attempted to enter the cabin near row 1; however, the smoke and flames were too intense. Returning to the R1 door, he jumped to the ground.

Several passengers who had been seated in the coach cabin between rows 4 and 13 escaped via the two overwing emergency exits and the R3 service door. Because of the fire, only two passengers were able to escape from the left overwing emergency exit. They crawled along the left wing and jumped from the leading edge of the wing to the ground.

About 37 passengers escaped via the right overwing emergency exit. Their egress was hampered by the passenger seated in seat 10F who stated that she was very frightened and froze and was unable to leave her seat or open the window exit next to her. The male passenger seated in 11D climbed over the 10E seatback and opened the overwing exit; he pushed the passenger seated in 10F out the window and onto the wing and then followed her. During the subsequent evacuation through the right overwing exit, two male passengers had an altercation at the open exit that lasted several seconds.

The outboard seatback at 10F adjacent to the right overwing exit was found folded forward after the accident blocking approximately 25 percent of the exit opening. The retaining bolt at the seat's pivot point was sheared. The timing of this occurrence could not be determined.

Passengers who escaped by the right overwing exit made their way across the right wing and slid down the extended flaps. They were directed away from the aeroplane by flight attendants and firefighters who, they estimated, arrived on scene 1 to 2 minutes after the B-737 struck the abandoned fire station.

Passengers seated around row 10 stated that prior to departure the flight attendant assigned to the R1 position conducted a special oral briefing for the persons seated in and around row 10. Passengers stated that the instructions provided by the R1 flight attendant aided in their evacuation.

Fifteen passengers seated aft of the overwing area who made their way to the rear of the cabin reported using the emergency floor path lighting. All of the passengers stated that the cabin filled with thick black smoke within seconds of the impact with the building.

The L3 flight attendant stated that she slightly opened her door without difficulty before impact with the building; however, the outside of the door was ablaze so she closed the door. She had taken about two steps into the cabin when the building was struck. She did not return to the door. After the final impact, she attempted to make her way to the overwing exits in accordance with company procedure. Because of the number of passengers moving aft, she was only able to advance forward to the seats at rows 19 and 20 on the left. From there, she directed the passengers to the rear of the cabin.

After the final impact, the flight attendant who was assigned to the R3 door opened the door deploying the emergency slide and evacuated about 15 passengers. He then exited and directed passengers away from the aeroplane.

Four of the six exits were used during the emergency evacuation: the R1 forward service door, and left and right overwing emergency exits, and the R3 service door. The L1 exit was damaged subsequent to the secondary impact with the abandoned fire station. The L3 exit was opened by the L3 flight attendant during the slide to a stop between the first and second impacts; however, because of flames along the left side of the aeroplane, she stated that she closed the door and elected not to use it thereafter. Investigators found the door open with the slide deployed. It was determined that ARFF personnel had opened the door well after the accident.

The R1 slide pack did not deploy. It was found below the door in an area where the floor was burned away. The postcrash examination of the girt bar and its two retaining brackets revealed that the bolts that secured the retaining brackets to the floor on the inboard side of the door were bisected (sheared off at floor level). The R3 slide pack deployed as designed when the door was opened by the R3 flight attendant to initiate the emergency evacuation.

#### AIRCRAFT FACTORS

The aircraft was a B737-300 registered as N388US operated by USAir.

The cabin seating configuration was predominantly three abreast on either side of a central aisle. The total passenger capacity was 128.

The aircraft was manufactured in 1985. Although the interior was partially refurbished in 1989, most of the interior panel were from state-of-the-art materials at the time of original aircraft manufacture. The cabin seats contained fire-blocking material with Poly-Benzol Iomedizal (PBI). Floor proximity emergency lights were installed in the cabin.

The aircraft was fitted with two doors at the front and two doors at the rear of the passenger cabin. In addition there was an overwing emergency exit above each wing.

### ENVIRONMENTAL CONDITIONS

The accident happened at night with a visibility of 15 miles. Wind was 260 deg at 6 knots and the temperature was 14°C.

### INJURIES TO OCCUPANTS

Of the 89 persons aboard the B-737, 20 passengers, 1 flight attendant and the captain were fatally injured. Autopsies of the 19 passengers and 1 flight attendant who were removed from the wreckage revealed that they died of asphyxia due to smoke inhalation. One person who evacuated the aeroplane died as a result of thermal burns a few days later. The captain succumbed to multiple traumatic injuries. In addition, one passenger died of thermal burn injuries 31 days after the accident.

### **ACCIDENT SCENARIOS AND SURVIVABILITY CHAINS**

The accident is considered as four separate scenarios as shown in figure A-9. The survivability chains for these scenarios are as follows:



**Scenario 1** represents the flight compartment area. Of the two flight crew occupying this area, the captain sustained fatal injuries as a result of the impact. The other flight crew suffered serious fire burns.

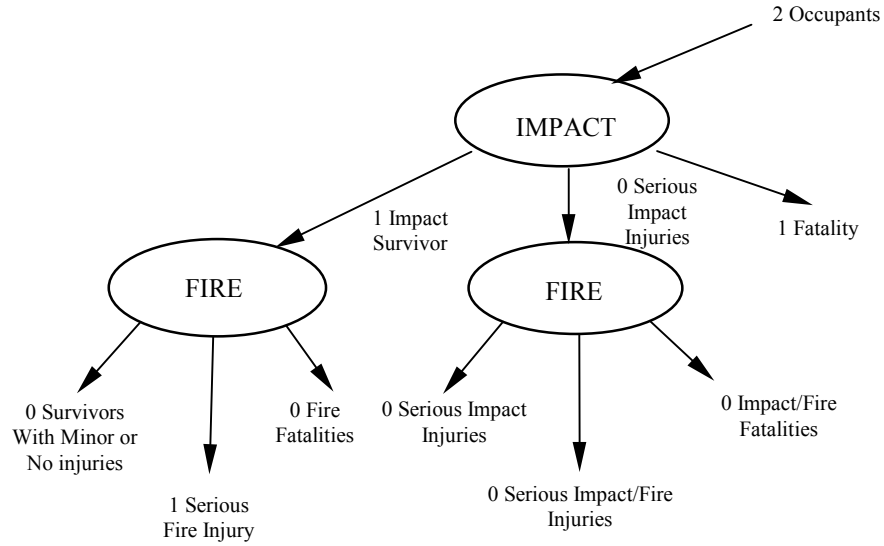

SCENARIO 1

**Scenario 2** represents the forward flight attendant area. One flight attendant died of asphyxia due to smoke inhalation and the other suffered serious fire burns.

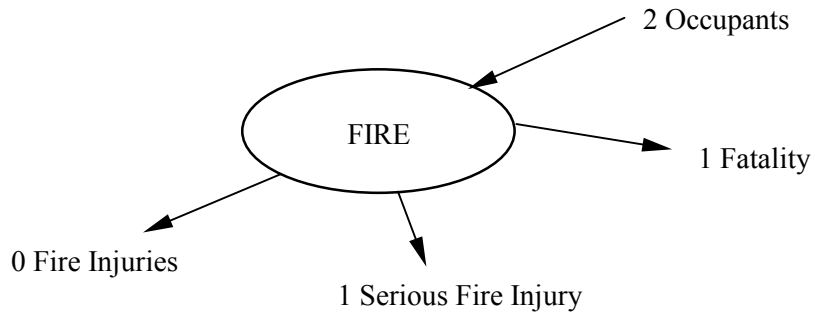

SCENARIO 2



**Scenario 3** represents the entire passenger cabin containing seat rows 1 to 22. This scenario contains 83 passengers. Nineteen passengers died of asphyxia due to smoke inhalation. One passenger died due to thermal burns. Eleven passengers suffered serious fire burns.



**Scenario 4** represents the aft cabin attendant area, which contains two flight attendants. Both of them suffered minor or no injuries.

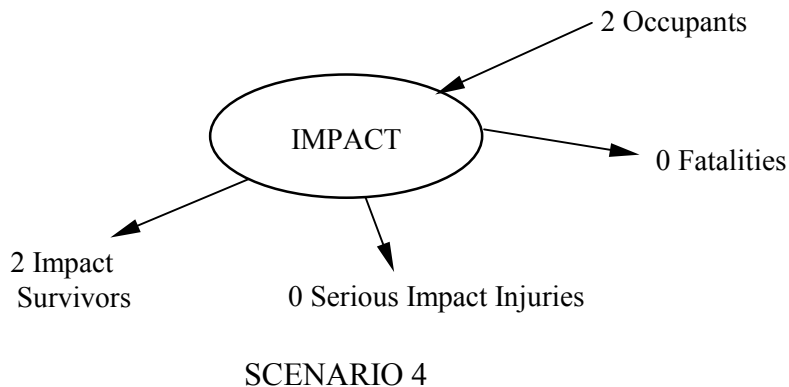

**EFFECT OF INTRODUCING 16-g SEATS**

Scenario 1

This scenario contains only flight crew seats and therefore benefit from the introduction of 16-g passenger seats is not applicable.

Scenario 2

This scenario contains only cabin crew seats and therefore benefit from the introduction of 16-g passenger seats is not applicable.

### Scenario 3

Although the cockpit on the captain's side was crushed in, there was very little impact damage to the passenger cabin. No seat failures or serious head impact injuries were identified in this accident. The only parts that separated from the aeroplane were the nose cone, nose gear doors, and the left pitot tube. All the fatalities in this scenario were as a result of asphyxia due to smoke inhalation and thermal burns.

The aircraft Flight Data Recorder indicated a maximum vertical acceleration of 1.43 g's. No data is currently available on longitudinal g; however, the deceleration levels must have been modest since there was no reported disruption due to the impact. Much of the aircraft energy was probably absorbed by the Metroliner.

Therefore, it is assessed that scenario 3 would remain unaffected by the introduction of 16-g seats.

### Scenario 4

This scenario contains only cabin crew seats and therefore benefit from the introduction of 16-g passenger seats is not applicable.

## ACCIDENT REF: 19920120A

Date:	20-Jan-1992	Flight Phase:	Approach
Aircraft:	A320	Location:	Strasbourg

### DESCRIPTION OF ACCIDENT

(The accident description is based on translations from the French Aircraft Accident Report.)

#### RESUME

On 20-Jan-1992 an Air Inter A320-111 registered as F-GGED was approaching Strasbourg, France.

The aircraft was inadvertently placed into a 3200 fpm vertical speed descent instead of the intended 3.2 degree flight path angle. The aircraft crashed into the top of a hill 10 nm short of the runway.

The aircraft was destroyed by the impact forces and by a minor postcrash fire.

Of the 6 crew and 90 passengers aboard, 5 crew and 82 passengers suffered fatal injuries. One crewmember and 4 passengers suffered serious injuries. Four passengers suffered minor injuries.

#### IMPACT

The service was a routine internal flight from Lyon-Satolas to Strasbourg-Entzheim. On reaching Strasbourg, the aircraft had clearance for a straight-in approach. This was declined as the aircraft was too high and fast and a request was made for an ILS approach. A VOR/DME approach was accepted.

From the CVR transcript it was clear that the crew correctly calculated a requirement for a 3.2-degree flight path angle. Speculation existed that the aircraft was inadvertently placed into a 3200 fpm vertical speed descent instead of the intended 3.2 degree flight path angle. The A320 utilises a common AFCS indication and control input.

(At about) the correct descent point the gear was lowered and a continuous descent of 3300 fpm was maintained until impact. As the speed increased the speedbrakes were deployed and it was assumed that this was to contain the speed below the flap limiting speed. The speedbrakes were retracted just before impact.

The aircraft crashed into the top of a hill known as La Bloss at a height of 2600 ft ASL, 0.5 nm left of the extended runway centreline, and 10 nm from the runway. At the time of impact the autopilot was engaged, the speedbrakes were retracted, the landing gear was down and the wings banked 18 degrees to the left.

Measurements taken of the damaged trees allowed a rough estimate that the aircraft entered the trees at an angle of descent of about 12 degrees, with a roll inclination to the left of the order of 18 degrees.

From the first impact with the trees, parts of the aircraft began to detach themselves: pieces of wing and front landing gear wheel. During sliding and collisions against the trees, the aircraft broke up considerably and dispersed with the main impact on the ground. The fuselage broke into three sections.

Only the central section of the fuselage at the level of the wings did not break up completely, although it was damaged by fire, especially on the right-hand side. All the seats, which were inside this section of the fuselage, were hurled outside it, along with their occupants. This part was situated at the front of the wreckage distribution area.

Behind the central section of the fuselage was the rear part of the floor of the passenger cabin. The passenger seats on this floor were relatively lightly damaged.

The rest of the aircraft was completely destroyed and scattered all over the area. In particular, the cockpit was damaged by the successive impacts with the ground and trees. Severely fragmented parts were found spread over a large area.

The DFDR was destroyed in the postcrash fire. The QAR suffered some damage but data were retrieved apart from the last 20 seconds. A transcript has been obtained from the area microphone in the flight deck with a few words missing, as the headsets were not in use.

The event reported by the survivors consisted of a very loud noise, sparks, and then total darkness. One of them mentioned that the aircraft was inclined to the left at the moment of impact.

#### FIRE

Fire broke out quickly, seeming to come from the front or the centre of the aircraft and working its way to the rear.

Several fires broke out on impact. Some of these were kept going by the survivors so that they could keep themselves warm.

The aircraft was eventually destroyed by the postcrash fire.

#### EVACUATION

There were 2 flight crew, 4 cabin crew, and 90 passengers on board.

When the descent was announced, the cabin staff asked the passengers to fasten their seat belts. The survivors who were interviewed reported that their seat belts were fastened during the descent.

Eight passengers and one flight attendant, all seated at the rear of the aircraft between row 28 and 31, survived the accident. Only one passenger remembers clearly how he got out of the wreckage by jumping from the floor of the aircraft (a drop of about 1 metre).

The slightly injured survivors helped those more seriously hurt. They all gathered together close to the tail of the aircraft in order to wait for help near one of the fires.

Very few details were documented on the rescue, except for the fact that it took 5 hours to locate the wreckage in the snow, fog, and darkness. The automatically triggered radio distress beacon did not function and was later found completely destroyed by the impact.

The investigation recommended that approval and installation of emergency locator transmitters be reviewed in order to increase the probability of their operation after an accident.

#### AIRCRAFT FACTORS

The aircraft was an A320-111, registered as F-GGED and operated by Air Inter.

The aircraft was production number 15, delivered to Air Inter in December 1988. It was similar to a British Airways A320 apart from the following:

1. GPWS was not fitted.
2. ACARS was operational for technical defects only.
3. A HUD was fitted for use in Cat III.

The aircraft was fitted with two doors at the front and two doors at the rear of the passenger cabin. In addition there were two overwing emergency exits over each wing.

#### ENVIRONMENTAL CONDITIONS

The accident occurred during the hours of darkness, with snow and fog on high ground.

Wind was reported as 040 deg at 20 knots and visibility as 5 miles. The ambient temperature was 1°C.

#### INJURIES TO OCCUPANTS

Of the 6 crew and 90 passengers aboard, 5 crew and 82 passengers suffered fatal injuries. One crewmember and four passengers suffered serious injuries. Four passengers suffered minor injuries.

According to survivor's statements, two fatalities succumbed to fire the remainder to the impact.

Eight passengers and a hostess survived the accident. Eight survivors were seated in the back extreme part of the cabin. One survivor was seated on the port side in row 14 next to the left wing. This passenger sustained multiples fractures to the ankles and he was probably ejected at the time of the impact.

The victims underwent a very violent frontal shock. Several of them were partially or completely carbonised. No trace of soot or pulmonary oedema was found with the examination of the higher air routes and the lungs, which would have been the sign of a fire or an explosion before the impact. All the victims had undergone polytraumatism. Certain injuries were observed on the level of the head, the pelvic belt, and the end of the lower limbs by the doctors who examined the bodies. According to these doctors, the injury noted on the level of the head could be due to impact against the structure of the seat located in front of the passenger. The injuries of the pelvic girdle would be due to the safety belts, which did not break. The injuries of the end of the lower limbs could be due to the lower part of the structure of the seats and the fasteners on the floor of the aircraft.

These various injuries have according to the report of the Institute of Forensic Medicine of Strasbourg, caused the immediate death of 81 victims (including the two supposed victims whose remains were not identified). The same report states that of the six victims whose death occurred after the impact, two would have probably survived if immediate help was available in the first 2 hours (they died during their transport). The four others could perhaps have had chances of survival if help was available in the first 30 minutes.

### **ACCIDENT SCENARIOS AND SURVIVABILITY CHAINS**

This accident is divided into five separate scenarios, as shown in figure A-10. Since the location of the fatally and the seriously injured occupants is unknown, it is assumed that the 90 passengers onboard the aircraft were evenly distributed in the cabin; i.e., 25 passengers in scenario 2, 25 passengers in scenario 3, and 40 passengers in scenario 4.



**Scenario 1** represents the flight deck and the vestibule area containing two flight crew and two cabin crew. All four crewmembers sustained fatal impact injuries in the impact.

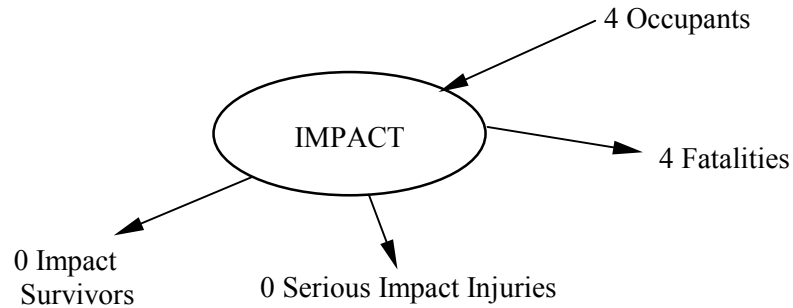

SCENARIO 1

**Scenario 2** represents seat rows 1 to 8. It is assumed that there were 25 passengers in this section and all died as a result of the impact.

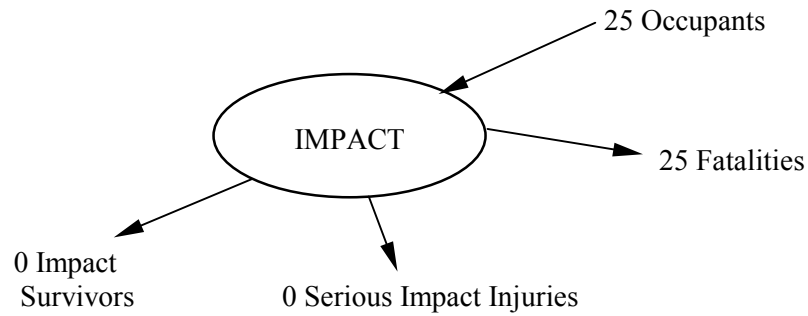

SCENARIO 2

**Scenario 3** represents seat rows 9 to 18. It is assumed that there were 25 passengers in this section and 22 of the passengers died as a result of the impact. Two passengers died as a result of impact and fire. One passenger sustained serious impact injuries. This passenger was ejected in his seat and received fractured ankles.

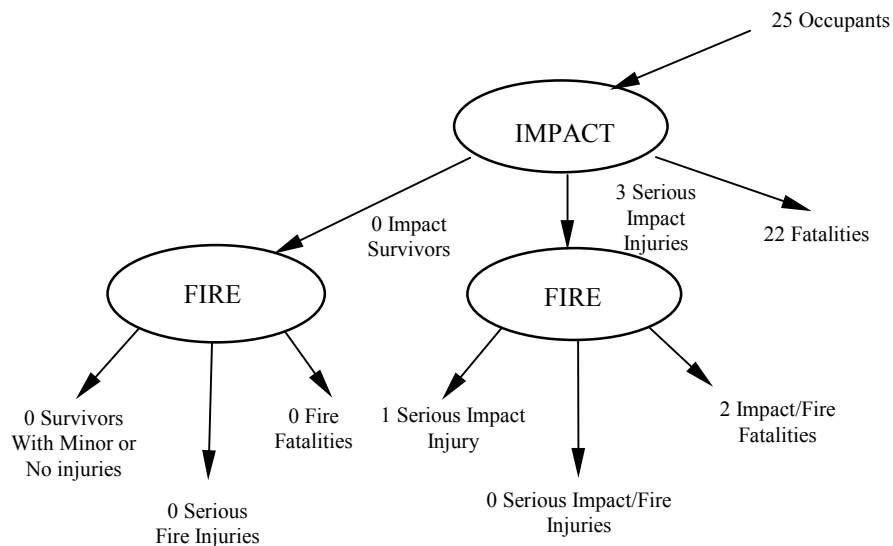

SCENARIO 3



**Scenario 4** contains seat rows 19 to 31. It is assumed that there were 40 passengers in this section, 33 passengers died as a result of the impact. Three passengers sustained serious impact injuries and four with minor or no injuries.

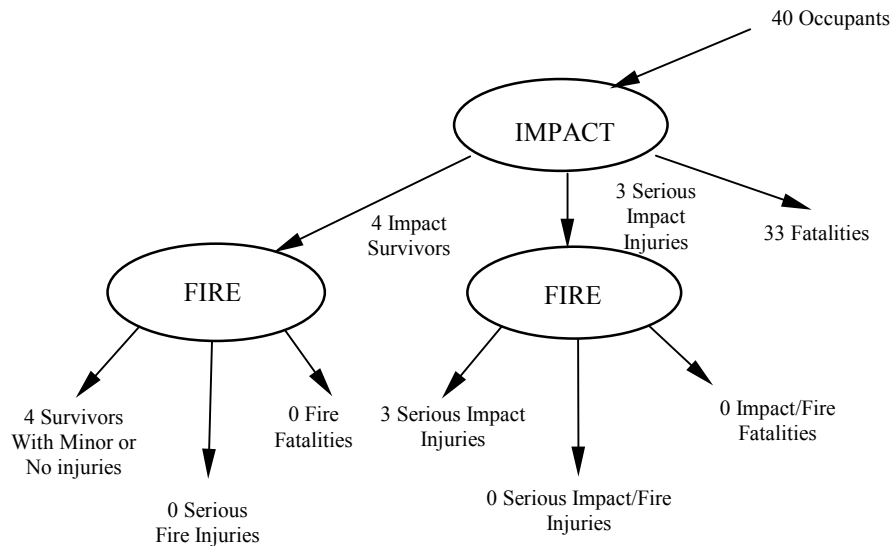

SCENARIO 4

**Scenario 5** represents the rear cabin crew area, containing two flight attendants. One flight attendant died as a direct result of the impact and the other flight attendant is assumed to have sustained serious injuries as a result of impact and fire.

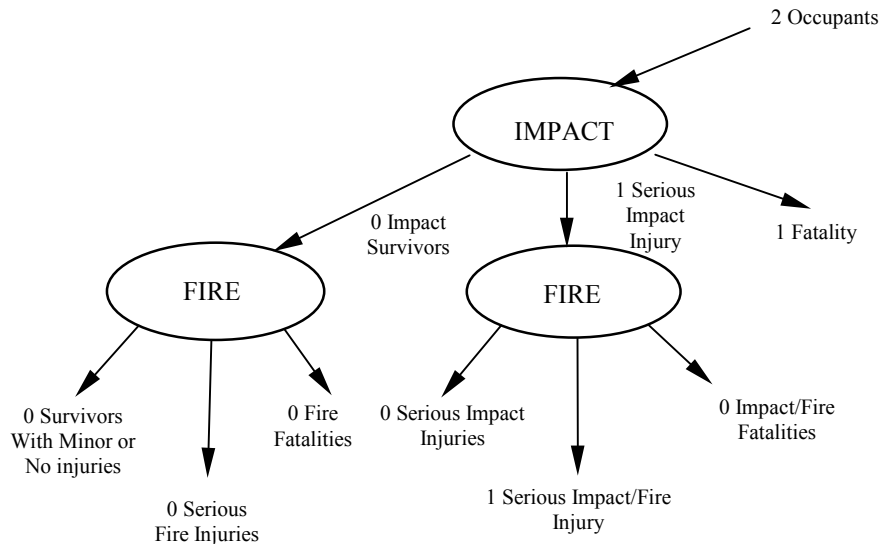

SCENARIO 5

**EFFECT OF INTRODUCING 16-g SEATS**

Based on information received by the analysts, it is assumed that the aircraft was not configured with 16-g seats.

### Scenarios 1 and 3

These scenarios contain only crew seats and therefore benefit from the introduction of 16-g passenger seats is not applicable.

### Scenario 2

The accident report stated that apart from the centre and the rear sections of the fuselage, the rest of the aircraft was completely destroyed by the successive impacts with the ground and trees. The debris was scattered all over the wreckage area. Due to the extent of the impact in this scenario, it is considered unlikely that there would be any reduction in the number of fatalities or serious injuries resulting from the introduction of 16-g seats.

### Scenario 3

The accident report states:

*“Only the central section of the fuselage at the level of the wings did not break up completely, although it was damaged by fire, especially on the right-hand side. All the seats, which were inside this section of the fuselage, were hurled outside it, along with their occupants. This part was situated at the front of the wreckage distribution area.”*

On this basis, it is considered unlikely that there would be any significant reduction in the number of fatalities resulting from the introduction of 16-g seats. However seat failure did occur, therefore it is possible that there would be some potential for a reduction in impact fatalities and serious injuries in this scenario. This section of the fuselage was also damaged by the postcrash fire.

The low assessment assumes the number of impact fatalities in this section of the aircraft is reduced from 22 to 18. It is further assumed that the four fatalities that might be saved by the use of 16-g seats would still sustain serious impact injuries. The three seriously injured passengers are reduced to minor or no injuries.

The high and median assessments assume there is no reduction in the number of impact fatalities and impact serious injuries.

Therefore the assessments of the injuries incurred had the aircraft been configured with the improved standard seats is as follows:

	<b>Minor or No Injuries</b>	<b>Serious Injuries</b>	<b>Fatal Injuries</b>
<b>High</b>	<b>0</b>	<b>3</b>	<b>22</b>
<b>Median</b>	<b>0</b>	<b>3</b>	<b>22</b>
<b>Low</b>	<b>3</b>	<b>4</b>	<b>18</b>

It is not known whether the aircraft was configured to the latest standard of fire requirements. However since all the passenger seats in this section were hurled outside the fuselage, the two fire injures were probably caused outside of the cabin. On this basis, it is considered that had the aircraft been configured to the latest standard of fire requirements there would be no change in the fire injuries sustained.

#### Scenario 4

The accident report states:

*“Behind the central section of the fuselage was the rear part of the floor of the passenger cabin. The passenger seats on this floor were relatively lightly damaged.”*

On this basis, it is feasible that there would be some reduction in the number of fatal and Serious Injuries had the aircraft been configured with fully compliant 16-g seats including the head injury criteria. However any saving is likely to be modest due to the severity of the impact. On this basis, the number of fatalities has been reduced by 6 for the median assessment and 11 for the low assessment. In both cases it is assumed that those previously sustaining fatal injuries will still be seriously injured. The serious injuries are assumed to reduce by one for the median assessment and all three that were previously seriously injured are assumed to be uninjured for the low assessment.

The standard of requirements with which the cabin materials complied with is unknown. However, it will have no effect on the prediction of the number of injuries and fatalities since in this scenario all survivors of the impact survived the fire.

Therefore the assessments of the injuries incurred had the aircraft been configured with the improved standard seats is as follows:

	<b>Minor or No Injuries</b>	<b>Serious Injuries</b>	<b>Fatal Injuries</b>
<b>High</b>	<b>4</b>	<b>3</b>	<b>33</b>
<b>Median</b>	<b>5</b>	<b>7</b>	<b>27</b>
<b>Low</b>	<b>7</b>	<b>11</b>	<b>22</b>

## ACCIDENT REF: 19920322A

Date:	22-Mar-1992	Flight Phase:	Takeoff
Aircraft:	F28	Location:	LaGuardia

### DESCRIPTION OF ACCIDENT

#### RESUME

On 22-Mar-1992 a USAir F-28-4000a registered as N485US was taking off from LaGuardia Airport, Flushing, New York.

The aircraft was operating under Title 14 Code of Federal Regulations Part 121 as a scheduled passenger flight.

Due to departure delays the aircraft accumulated ice on the wings and in addition the flight crew attempted to rotate at a lower than prescribed air speed. As a result the aircraft suffered an aerodynamic stall and loss of control after lift-off.

The aircraft came to rest partially inverted at the edge of Flushing Bay and parts of the fuselage and cockpit were submerged in water. After the aircraft came to rest, passengers stated that several small residual fires broke out on the water and on the wreckage debris.

The aircraft was destroyed during the impact sequence and subsequent fires.

Of the 4 crew and 47 passengers aboard, 2 crew and 25 passengers suffered fatal injuries. One crewmember and eight passengers suffered serious injuries. One crewmember and 14 passengers escaped with minor or no injuries.

#### IMPACT

A thin layer of wet snow covered the runway. The aircraft suffered 35 minutes of exposure to precipitation following de-icing and as a result accumulated ice on the wings.

The first officer described the takeoff as normal through the rotation. He stated that no problem was evident with vibration, rate of acceleration, ambient noise, and directional control and that takeoff was initiated with a smooth gradual rotation to 15 degrees at the normal rate of 3 degrees per second. He was aware that the main landing gear came off the runway but as they were still in ground effect a pronounced buffet developed in the airframe.

At approximately 2.2 seconds after the VR callout, the CVR recorded a sound similar to nose strut extension. Approximately 4.8 seconds after nose strut extension, the sound of stick shaker began and continued until the end of the CVR recording.

The first officer stated that they began rolling to the left just like they had lost lift. He stated that as the captain levelled the wings they headed toward the blackness over the water and that he joined the captain on the controls. The first officer said that they seemed to agree that the aircraft was not going to fly and that their control inputs were in unison. He did not remember any aileron input and there were no heavy control inputs. They used right rudder to manoeuvre the aircraft back toward the ground and avoid the water. They continued to try to hold the nose up to impact in a flat attitude. He said that there was at least one cycle of nose pitch oscillation accompanying the buffet. The first officer stated that he did not touch the power levers. The last thing he remembered was an orange and white building that disappeared under the nose. He recalled a flash, a jolt, a rumbling along the ground and then a sudden stop.

The aircraft came to rest partially inverted at the edge of Flushing Bay and parts of the fuselage and cockpit were submerged in water.

The initial ground scrape marks from the aircraft were approximately 4,250 feet from the threshold of the runway and about 36 feet left of the runway centreline and ranged from 5 feet to 65 feet long. Aluminium particles and paint chips were found on these scrape marks. About 200 feet farther along the runway, plexiglass lens cover pieces were found that matched the plexiglass from the left wing tip. There were no other impact marks found on the runway that could be associated with the aircraft.

The fuselage separated primarily into four sections during the impact sequence. The first section, from the nose to just aft of the fourth passenger window, came to rest upside down and partially submerged in Flushing Bay. The captain's windshield was intact but sustained impact damage. The captain's aft window had no damage. The first officer's windshield had minor scratches. The first officer's sliding window was closed and undamaged and the side window was scratched. There was no evidence of bird feathers or foreign objects on or near the cockpit windows.

The left side and bottom of the forward section was crushed by impact forces. A hole was in the fuselage skin to the left of the pilot's seat. The left main entrance door was found in the closed position and had no external damage. The left side fuselage skin exhibited sooting. The right side of the forward fuselage section sustained minor damage near the roof, which exhibited compression wrinkles. The right side fuselage skin exhibited sooting. The right side service/emergency door was not found.

A second section of the fuselage, from just aft of the fourth passenger window to the eleventh passenger window, was found floating in the water. The floor and corresponding bottom structure was torn and showed fire damage, and part of the floor structure was found attached to the first section. The roof and left side structure showed compression buckling and contained soot.

The third section of the fuselage, from the eleventh passenger window to approximately the aft bulkhead, was found submerged in the water. The left fuselage skin and the crown were destroyed by fire. A portion of the fuselage skin was intact on the right side. There was fire

damage to the aft section. The left wing attachment structure to the fuselage, comprised of “Z” section stringers, exhibited extensive upward and slightly aft bending. There was no indication of fire damage in this area. A short section of the right wing, about 3 feet long, remained attached to the fuselage. The fuselage around the right wing attachment was fire damaged, and the soot pattern indicated the direction of fire from bottom to top. Both emergency exit doors on the right side were missing. The right aft cargo compartment was fire damaged, and the right aft lower fuselage had impact damage with buckling and twisting of the skin. The crush was from outboard to inboard, tearing the stringers and the skin attached to them.

The fourth section of the fuselage, the empennage, was found at the main wreckage site resting on the left horizontal stabilizer. The tail cone was not damaged. The vertical stabilizer and the rudder assembly remained attached to the empennage.

The landing gear were damaged and were found in the down and locked position.

Nineteen of the 28 seats had separated from the cabin floor and were scattered throughout the wreckage and 6 of them were fire damaged. The remaining nine seats were not recovered. Of these 19 seats, 10 were from the right side of the cabin and 9 were from the left side. Only one first class seat unit at row 1D, 1F remained partially attached to the floor following the water recovery of the aircraft. Seats that were near the front of the cabin sustained less damage than those in the rear.

#### FIRE

No evidence of preimpact fire was found. Several surviving passengers reported fires in the forward left and aft portions of the aircraft after the initial impact.

After the aircraft came to rest, passengers stated that several small residual fires broke out on the water and on the wreckage debris.

Aircraft rescue and firefighters (ARFF) responded to the accident scene, extinguished the fires and began rescue efforts.

ARFF personnel reported that snow and fog hampered their visibility during the response. As a result, vehicle speeds were reduced and the aircraft was not visible to them. The ARFF crew chief reported that they arrived in the area about 4 minutes after notification and applied extinguishing agent to a burning pump house. At that time the aircraft was not visible to them, however the crew chief observed people on top of the dike. He donned his self-contained breathing apparatus and climbed the dike where he observed the burning aircraft in the water. ARFF personnel used the crash truck turrets to apply extinguishing agent over the dike to the burning fuselage. Since the turret operators, who were inside the trucks, could not see the fuselage, firefighters proceeded to the top of the dike to direct the aiming of the turrets with hand signals. The incident commander estimated that the fire was under control in 10 minutes.

## EVACUATION

There were 2 flight crew, 2 cabin crew, and 47 passengers aboard.

Prior to impact, passengers did not assume the brace position. When the aircraft came to rest, many of the passengers in the forward portion of the cabin were upside down, while others, who were upright, were submerged in water over their heads. Some passengers tried to move from their seats while their seatbelts were still buckled and other passengers had difficulty locating and releasing their seatbelt buckles because of disorientation.

Passengers stated that they escaped through large holes in the cabin. None of the exits were used. The lead flight attendant and first officer escaped through a hole in the cabin floor near the flight attendant's position. Several passengers reported assisting others out of the cabin and into the knee-deep water. Many of them walked in the water to the dike, climbed up the wall, over an embankment and slid down a steep hill to the runway. Others were assisted out of the water by ground personnel.

Fatally injured passengers were between rows 4 and 11, near the overwing exits and at row 13.

The examination of the passenger safety briefing cards found in the airplane showed two types of galley service doors (R1). However, only one door is installed on a particular F-28 model at any one time. The examination also showed that the safety card did not show how to operate either of the two types of galley service doors in the emergency mode if the normal operating mode failed. In addition, the overwing briefing card depicts a plastic cover over the release handle and an opening in the cover to permit the cover's removal. Examination of another F-28 revealed that the opening in the plastic cover is shielded by thin plastic that has to be broken before a person can place his or her fingers into the cover to remove it.

## AIRCRAFT FACTORS

The aircraft was an F-28 Mk 4000a registered as N485US and operated by USAir.

The aircraft was manufactured in the Netherlands as serial number 11235 and was delivered on 19-Aug-1986. Its original type certificate was approved by the Civil Aviation Authority of the Netherlands. The FAA accepted the certification of the aircraft under the Bilateral Airworthiness Agreement.

The cockpit was of the standard captain and first officer configuration.

The cabin was configured into two sections. The first-class section had a forward facing double-occupancy seat unit on the left side labelled 1A, 1C and one forward facing double-occupancy seat unit on the right side labelled 1D, 1F for a total of four seats. The coach section was configured with 13 rows of forward facing double-occupancy seat units on the left side of the cabin labelled 2A, 2C through 14A, 14C and one forward facing double-occupancy seat unit

labelled 2D, 2F followed by 12 rows of forward facing triple-occupancy seat units on the right labelled 3D, 3E, 3F through 14D, 14E, 14F. Hence there were 64 seats in the coach section.

There were two cabin crew jumpseat locations in the cabin that were single units and forward facing. One cabin crew seat was in the right front of the aircraft between Galley 1 and Galley 2. The second cabin crew seat was in the rear of the fuselage between the left and right lavatories.

The cabin was fitted with a passenger entry door at the front on the port side and a service door opposite. There were two overwing emergency exits above each wing.

#### ENVIRONMENTAL CONDITIONS

The accident occurred during the hours of darkness.

Visibility was 0.75 mile in light snow and fog. Wind was 060 degrees at 13 knots. The ambient temperature was 0°C.

The LaGuardia weather observer measured 1 inch of snow 1.5 hours before the accident, 0.5 inch 0.5 hour before and 0.4 inch at the time of the accident. He characterised the snow as wet.

#### INJURIES TO OCCUPANTS

Of the 4 crew and 47 passengers aboard, 1 flight crew, 1 cabin crew, and 25 passengers suffered fatal injuries. One cabin crewmember and 8 passengers suffered serious injuries. One cabin crewmember and 11 passengers escaped with minor or no injuries. Records were not received for three passengers who refused treatment [assumed to be minor/no injuries].

Of the 27 occupants who died, 8 of them sustained minor injuries and died as a result of drowning, 7 sustained serious injuries and died as a result of drowning, 9 died as a result of blunt force trauma, 1 died as a result of smoke inhalation/burns, 1 died from burns, and 1 survived for several hours but subsequently died in hospital with cervical spine injuries.

Some of the 24 survivors sustained injuries that consisted of fractures of the lower extremities, ribs, and arms; first-, second-, and third-degree burns to heads, hands, arms, and legs; as well as multiple contusions, abrasions, and lacerations.



## ACCIDENT SCENARIOS AND SURVIVABILITY CHAINS

This accident is divided into four separate scenarios, as shown in figure A-11. Within scenario 3, three survivability chains were used to represent the injuries.

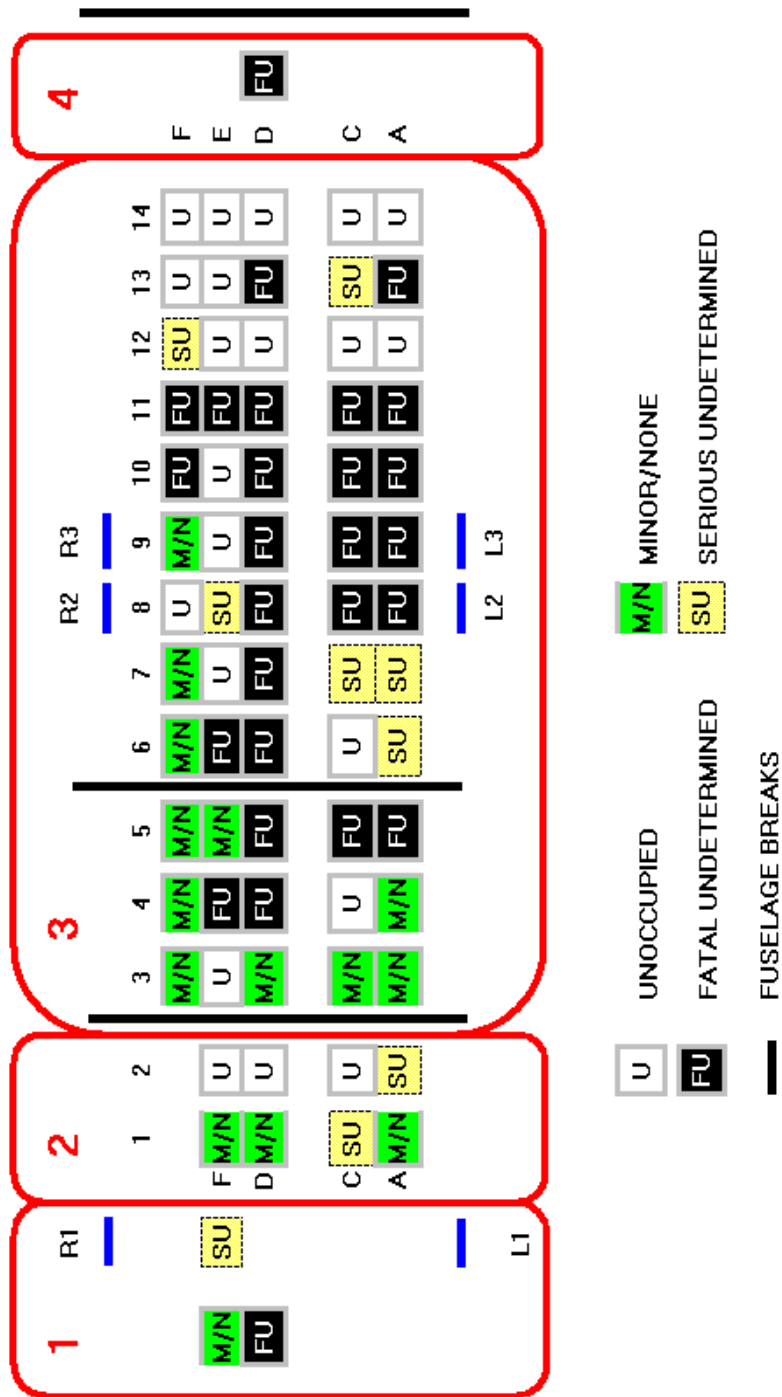
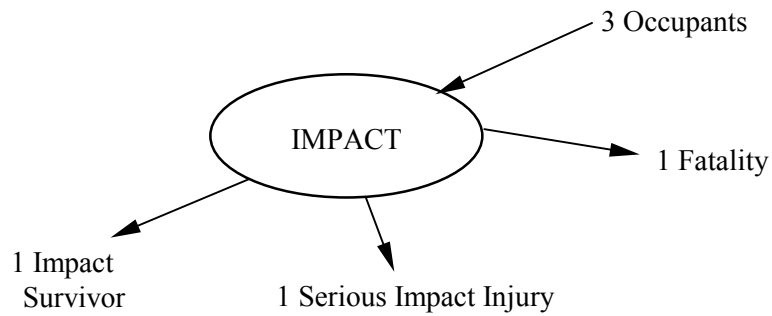

FIGURE A-11. LOCATION OF INJURIES AND SCENARIOS

**Scenario 1** contains the flight deck and the forward galley area which was subjected to impact damage. The scenario contains two flight crew and one flight attendant. Due to absence of detailed documentary evidence on the location of injuries, it is assumed that the captain died of blunt force trauma and the flight attendant sustained serious impact-related injuries. This is based on the fact that the left side and bottom of this section were crushed by impact forces. A hole was in the fuselage skin to the left of the captain's seat. The floor on the left side of the cockpit and the captain's seat pedestal were displaced upward. The right side of the forward fuselage near the roof exhibited compression wrinkles. There was no sign of any fire damage in this section.



SCENARIO 1

**Scenario 2** contains passenger seat rows 1 and 2 which were subjected to impact damage. The scenario contains five passengers, three of whom suffered minor or no injuries and two suffered serious injuries.

Due to the absence of detailed documentary evidence on the location of injuries, it is assumed that the two injured passengers sustained serious impact-related injuries. This section suffered impact damage and the right side of the forward fuselage near the roof exhibited compression wrinkles. There was no sign of any fire damage in this section.

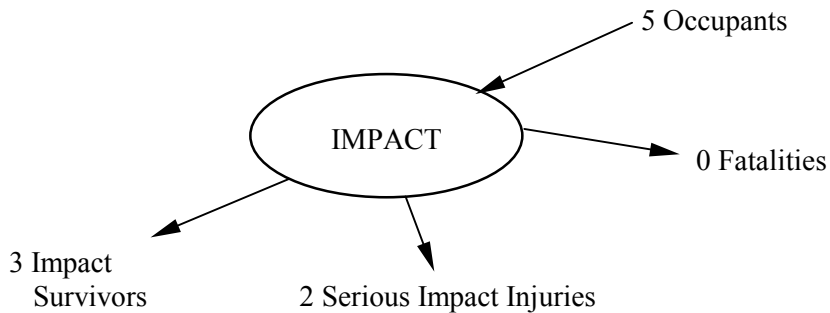

SCENARIO 2

**Scenario 3 - Chain 1** represents those occupants in seat rows 3 to 14 who were subjected to the impact and then immersion in water. It contains 37 passengers. Eight passengers suffered fatal impact injuries, 7 passengers sustained serious injuries and died as a result of drowning, 8 passengers sustained minor impact injuries and died as a result of drowning, and 11 passengers received minor or no injuries. Due to the absence of detailed information on the location of injuries, it is assumed that three of the six seriously injured survivors sustained only impact injuries, but not head injuries.

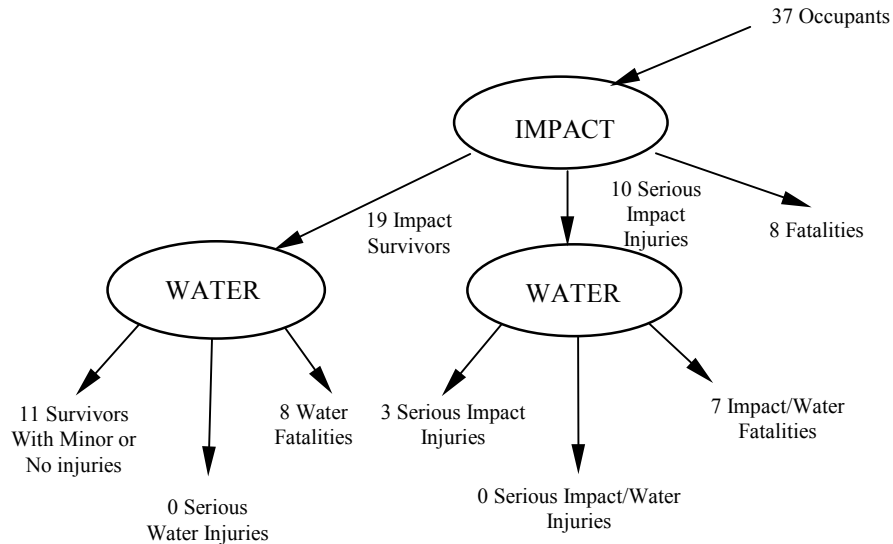

CHAIN 1

**Scenario 3 - Chain 2** represents those occupants seated between rows 6 to 13 who were seriously injured in the accident. Due to the absence of detailed information on the location of injuries, it is assumed that the three seriously impact injured survivors also suffered thermal burns but no head injuries. This is consistent with the data in the accident report.

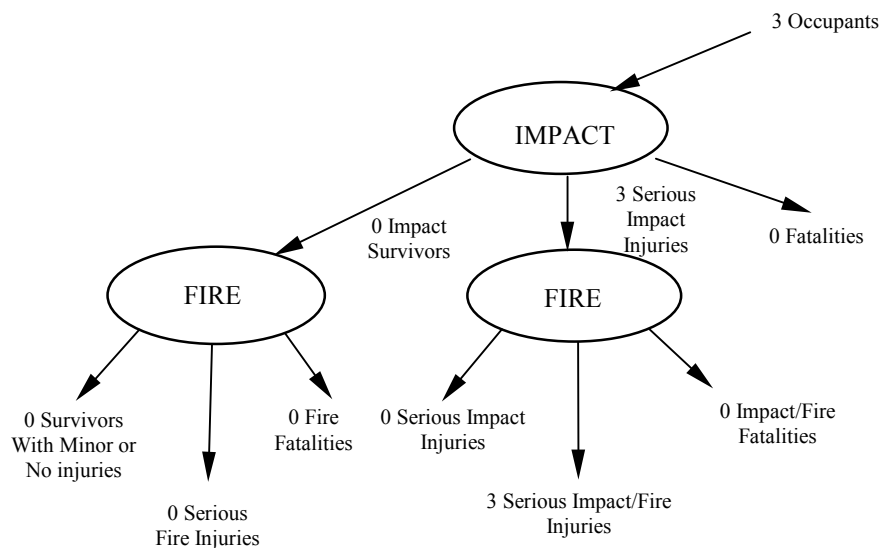

CHAIN 2

**Scenario 3 – Chain 3** represents the two occupants seated between rows 3 to 14 who were killed by the postaccident fire.

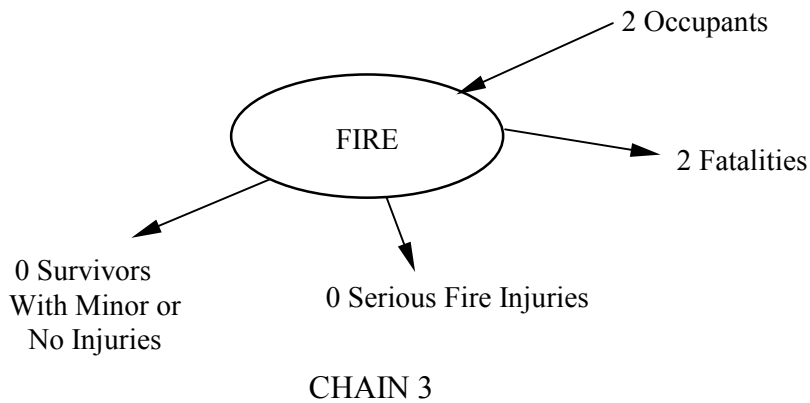

**Scenario 4** represents the rear flight attendant's area which contains one flight attendant. Due to absence of detailed documentary evidence on the location of injuries, it is assumed that the flight attendant died of blunt force trauma.

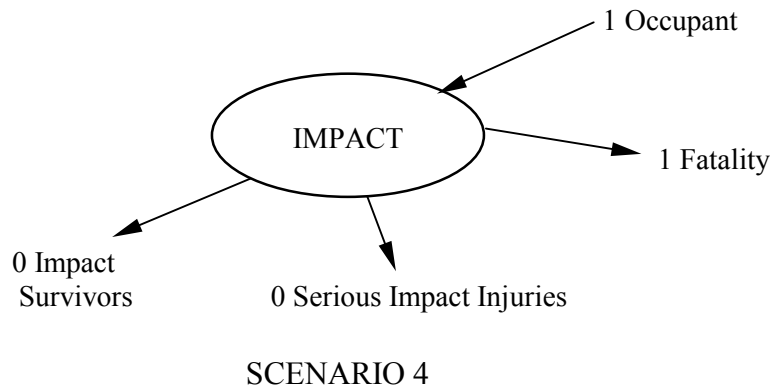

### **EFFECT OF INTRODUCING 16-g SEATS**

#### **Scenarios 1 and 4**

These scenarios contain only flight and cabin crew seats therefore benefit from the introduction of 16-g passenger seats is not applicable.

#### **Scenario 2**

In the accident report, it was stated that only one first class seat unit at row 1DF remained partially attached to the floor. This means the seat unit 1AC was detached from the floor. It was also reported that seats that were near the front of the cabin sustained less damage than those in the rear. Therefore it is assumed that the seat units in row 2 remained attached to the floor. On

this basis, it is assessed that if 16-g seats were used, there would be a modest reduction of one serious injury.

The best possible situation is that all injuries would have been avoided had fully compliant 16-g seats been fitted to the aircraft. Therefore, the low assessment would be that all five occupants of this scenario would have survived uninjured.

The high assessment is based on the assumption that there would be no change in the injuries sustained.

The high, median, and low predictions of the number of impact fatalities and injuries resulting from the use of 16-g seats are:

	<b>Minor or No Injuries</b>	<b>Serious Injuries</b>	<b>Fatal Injuries</b>
<b>High</b>	<b>3</b>	<b>2</b>	<b>0</b>
<b>Median</b>	<b>4</b>	<b>1</b>	<b>0</b>
<b>Low</b>	<b>5</b>	<b>0</b>	<b>0</b>

### Scenario 3, Chain 1

It was reported that 19 of the 28 seat units had separated from the cabin floor and were scattered throughout the wreckage. Of these 19 seats, 10 were from the right side and 9 were from the left side. Therefore, it is assumed that seat rows 4 to 13 (total 10 seat units) on the right side and rows 1 (covered in Scenario 2), 5 to 11, and 13 (total 9 seat units) on the left side were separated during the impact sequence. Hence, there were fatal and serious injuries on these seats. However the accident report states ‘some of the 24 survivors sustained injuries that consisted of fractures of the lower extremities, ribs and arms, first, second and third degree burns to heads, hands, arms and legs as well as multiple contusions, abrasions and lacerations.’ On this basis, it is assumed that head injuries were not a significant factor in this accident.

It is assessed that introducing 16-g seats in this scenario may have reduced the number of fatalities and serious injuries.

The low assessment assumes that all 37 occupants would be saved from serious injuries.

The high assessment assumes no reduction in fatalities and serious injuries.

The median assessment is taken as the average of the high and the low assessments.

The high, median, and low predictions of the number of impact fatalities and injuries resulting from the use of 16-g seats are:

	Minor or No Injuries	Serious Injuries	Fatal Injuries
High	19	10	8
Median	28	5	4
Low	37	0	0

It should be noted that any additional survivors of the impact would be subjected to the risk of drowning. This is catered for in the mathematical model.

Scenario 3, Chain 2

It is assumed that the aircraft was not configured with cabin materials compliant with the heat release requirements of the FAR 25 at amendment 61. It is further assumed that had this been the case the three impact injured passengers would not have sustained fire injuries. The survivability chain is thus modified as follows:

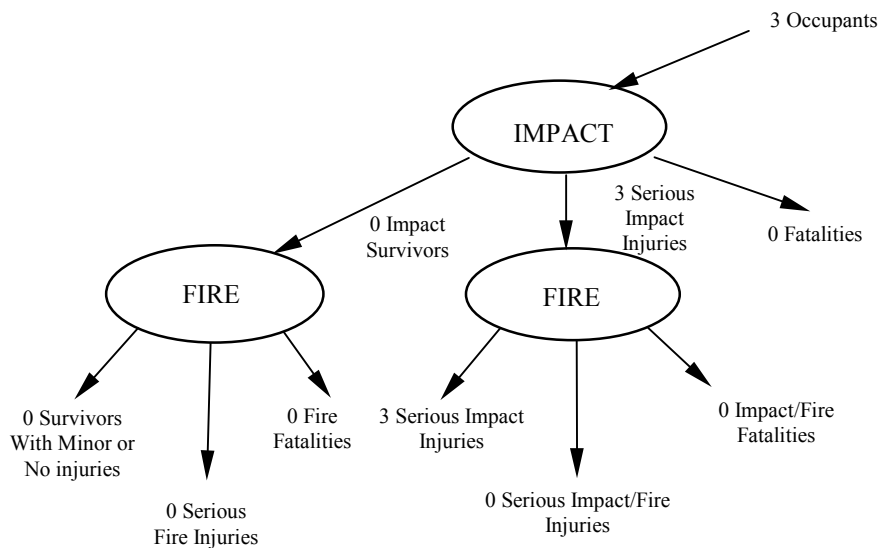

CHAIN 2

Since detailed information on seat related injuries is not available, the high assessment is taken as there being no change in the number of passengers seriously injured in the impact. The low assessment is based on all three passengers surviving the impact uninjured had fully compliant 16-g seats been installed. The median assessment is taken as being the average of these two extremes. This assessment is summarised as follows:

	<b>Minor or No Injuries</b>	<b>Serious Injuries</b>	<b>Fatal Injuries</b>
<b>High</b>	<b>0</b>	<b>3</b>	<b>0</b>
<b>Median</b>	<b>2</b>	<b>1</b>	<b>0</b>
<b>Low</b>	<b>3</b>	<b>0</b>	<b>0</b>

Scenario 3, Chain 3

This chain contains only threat by fire and therefore benefit from the introduction of 16-g passenger seats is not applicable.

## ACCIDENT REF: 19921221A

Date:	21-Dec-1992	Flight Phase:	Approach
Aircraft:	DC10	Location:	Faro

### DESCRIPTION OF ACCIDENT

#### RESUME

On 21-Dec-1992 a Martin Air DC-10-30CF registered as PH-MBN was approaching Faro Airport, Portugal. After a flight of 2 hrs and 17 minutes, the flight was cleared to descend to Faro.

At an altitude of 303 m and 140 kts speed the approach became unstable and at 177 m the first officer switched the autopilot from CMD (command mode) to CWS (control-wheel steering). One minute later it was switched from CWS to manual and the airspeed began falling below approach reference speed. About 3-4 seconds short of touchdown, the elevator was pulled to pitch up and engine power was increased. When the No. 3 and 5 spoilers extended, the aircraft had a 25 deg. bank, left wing up. The right main gear contacted the runway with a 900 ft/min descent rate at 126 kts, +8.79 deg, pitch up, +5.62 deg roll, and 1,9533-g. The right wing separated while the aircraft slid down the runway. The aircraft came to rest 1100 m from the Runway threshold and 100 m to the right of the centreline and caught fire.

There were 13 crew and 327 passengers on board. Two crew and 54 passengers suffered fatal injuries.

#### IMPACT

A sudden and unexpected wind variation in direction and speed (windshear) occurred in the final stage of the approach. Subsequently a high rate of descent and an extreme lateral displacement developed, causing a hard landing on the right hand main gear, which in combination with a considerable crabangle exceeded the aircraft structural limitations. The fuselage broke into 4 main sections.

Seat rows 1 to 10 - This section (1) came to rest on its left side at 70 deg. There was no fire.

Seat rows 11 to 19 - This section (2) corresponds to the transverse rupture of the cabin due to the longitudinal twisting moment of the fuselage.

Seat rows 20 to 27 - This section (3) corresponds to where, upon first strike, fire propagated in from the right wing.

Seat rows 28 to 41 - This section (4) contains the cabin which structurally resisted the crash most and where evacuation was possible.



## FIRE

On impact, a fire started on the right wing and propagated into the cabin from the right side. The forward fuselage section (1) contained no fire. The mid-forward section (2) ruptured partly as a result of fire-based explosions while the aircraft was off the runway. The mid-rearward section (3) corresponds to where, upon first strike, fire propagated, coming from the right wing. The rear section (4) allowed evacuation for 4 minutes before an explosion relit the fire in the mid section which consumed the whole section.

## EVACUATION

There were 13 crew and 327 passengers aboard. The cabin was configured for 336 seats (24 first class and 312 economy class).

In the forward section (1) passengers and crewmembers exited through holes in the cabin walls, since none of the 4 exits were operational. L1 and L2 were half buried in the ground and R1 and R2 were unused since they were almost vertical.

In the mid-forward section (2) the passengers and crewmembers exited exclusively through a fuselage break, mainly through the left side. Most of the passengers who were aware of having been ejected (94%) were sitting in this section, which records also the greatest number of ejected passengers for the total survivals (37%).

In the mid-rearward section (3) an explosion occurred soon after the aircraft came to a halt. Sixty-one percent of the people seated in this section died. Of the survivors, 52% claim not being aware of how they managed to get out of the aircraft. The remaining survivors claim to have exited through ruptures, either in the fuselage walls or in the cabin floor. Only 2 passengers state having used the emergency exit on the left wing (L3) which was burst open by the explosion. The R3 exit was not used. Among the fatalities, there were two flight attendants. Some passengers witnessed that the flight attendants vanished surrounded by a fireball when the explosion happened.

In the rear section (4), evacuation was carried out in less than 4 minutes through the two rear exits (R4 and L4) before an explosion relit the fire in the mid section which spread to the rear section. From the total number of occupants in this section, 97.6% survived. Most of them recall having come out through rear exits, though they cannot state which side it was. The L4 exit opened spontaneously before the aircraft came to a halt. The escape slide was partially deployed. Most of the passengers used this exit, being immediately covered by the firemen's foam. The R4 exit was opened by the R4 stewardess and the escape slide partially deployed. The two rear stewardesses decided to suspend evacuation through this exit due to the flames outside.

According to the R4 stewardess, after the "Fasten Seatbelts" sign came on she considered the flight was turbulent and was threatening. She looked across to the L4 stewardess and then the "No Smoking" sign came on. She did not hear the undercarriage come down. She looked across

again at the L4 stewardess and saw her in the brace position. The R4 stewardess then consciously took the same position. She remained in this position and waited to land. Suddenly she heard a bang and from the overwing position saw a jumble of loose objects coming towards her and also some light partitions. She saw an orange-yellow coloured light near exits R3 and L3.

She turned her face away to the right, looking at the exit, and kept the door handle in view, at the same time keeping her left hand on her seatbuckle. When the aircraft came to a stop she released her belt in one movement and opened the R4 exit. The handle position was in AUTO but she did not see the slide or hear the noise of a slide inflating. When the exit was open she saw a dark, black hole and saw a glow. The next moment the L4 stewardess appeared and told her to assist. Passengers came to the exit and especially the women needed pushing to get them out. During the evacuation the L4 stewardess told her that there was no slide. The L4 stewardess pulled the manual inflation handle but it came off in her hand. Since the R4 stewardess did not know the height that the passengers had to jump nor the surface on which they came down, she decided to stop evacuating through this exit and to divert the passengers to the L4 exit. She knew this exit was open and since the aircraft was banked left, in her opinion, she thought the height there was smaller.

Up to that moment she did not have time to look into the cabin. All the time she had been yelling "Get out, get out." Looking past the passengers she saw a glow which she associated with a fire. The glow came closer. Through the L4 exit she saw foam coming in which gave her a safe feeling and she knew that she had done well to get passengers to that exit.

Eventually it quietened down and she started pushing the last passenger out. She directed some more passengers out past the coffee bar and saw the L4 stewardess having problems with a woman who could not jump out. The L4 stewardess drew the attention of the R4 stewardess to a man who was walking in the aisle 5 to 6 rows away. It was an old man stumbling to an exit. The R4 stewardess walked to the man and saw a big hole in the cabin. She got the impression there was nobody left in that part and that nothing else was left of the aircraft. She then left through exit L4 and noticed that there was no slide. She met the R4 stewardess and walked away from the aircraft.

According to the L2 stewardess, before landing, the captain told her that it was advisable that everybody took their seats. She passed this on to her colleagues. She took her seat at position L2 which was rearward facing. She left the airshow on so that the passengers could follow the airspeed and altitude during approach. The main reason for this was that she did not want anybody to stand up. Because of the bad weather she assumed the brace position.

She heard and felt a hard bang or explosion, which she immediately related to the aircraft touching the concrete. Just in front of her a ceiling panel came adrift and a luggage bin opened. She saw more things coming adrift and heard another bang. She saw a spout of fire coming up towards the cabin and enter the cabin on both sides of the window next to position 24K. There were two fireballs which disappeared again and then no fire. When nothing more fell down and

the rolling movement had stopped, she saw fire about two seat rows away over the whole width of the cabin.

She immediately called “Get out” although she did not see anybody in the chaos which existed. She tried to make it clear to the passengers that they had to leave. However she was trapped and could not release her seatbelt. With the assistance of a passenger she got free. The L2 exit turned out to be below her and above her she saw a hole through which people were clambering to get outside. She climbed on a row of seats and got out amongst the passengers.

#### AIRCRAFT FACTORS

The aircraft was a DC-10-30CF registered as PH-MBN and operated by Martin Air of Holland.

The cabin was fitted with four passenger entry doors along each side. One of which was located above the wing.

#### ENVIRONMENTAL CONDITIONS

The accident occurred in heavy rain. Wind was between 200 deg and 160 deg at between 29 and 21 kts, gusting to 34 kts.

#### INJURIES TO OCCUPANTS

There were 13 crew and 327 passengers on board. Two crew and 54 passengers suffered fatal injuries. The two crew fatalities were positioned at exits R3 and L3 where the fire entered the cabin.

## ACCIDENT SCENARIOS AND SURVIVABILITY CHAINS

This accident is divided into seven separate scenarios, as shown in figure A-12. Scenarios 3 to 6 are bounded by the fuselage ruptures.

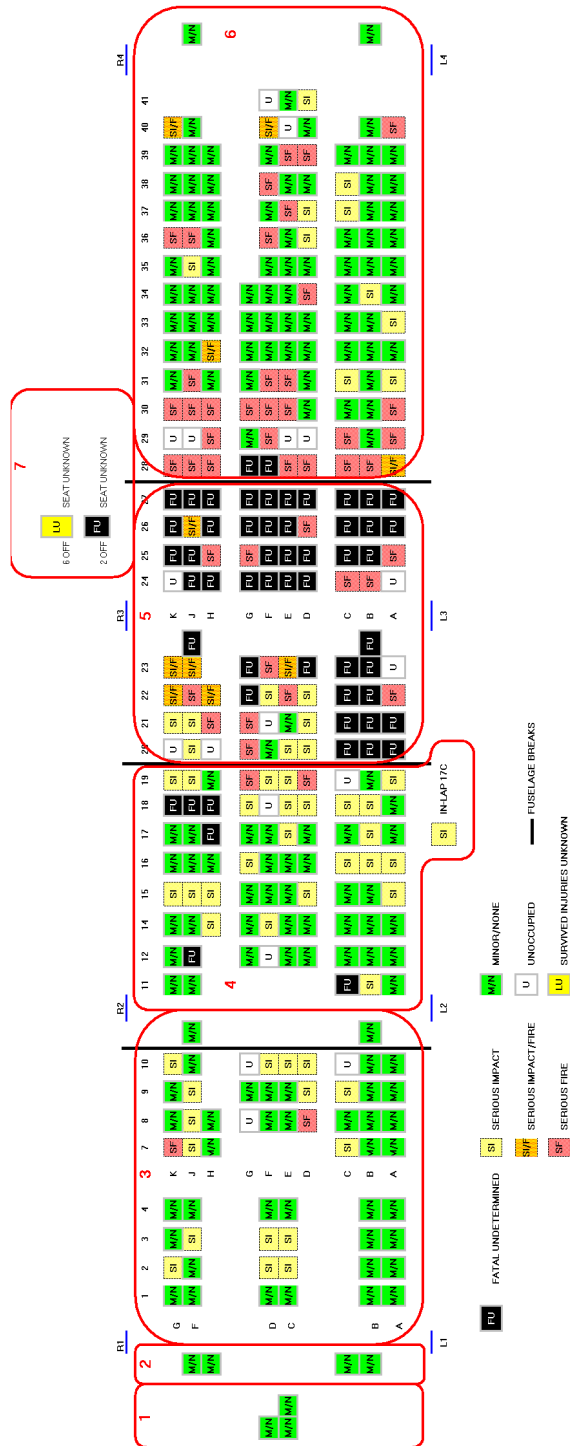
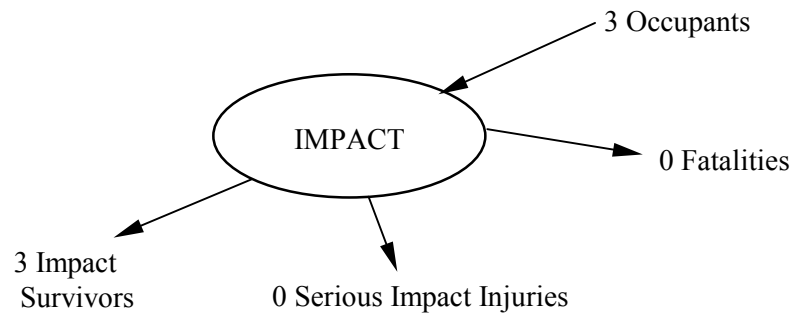

FIGURE A-12. LOCATION OF INJURIES AND SCENARIOS

**Scenario 1** contains the flight deck area which was subjected to the impact and was not fire damaged. The scenario contains the three flight crew.



SCENARIO 1

**Scenario 2** contains the forward flight attendant area and encompasses four flight attendants, none of whom sustained serious or fatal injuries.

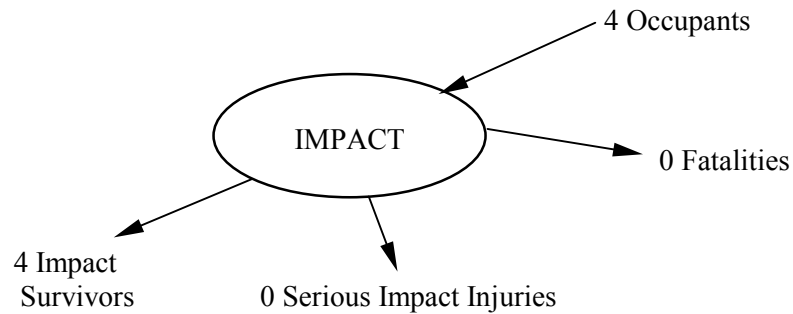

SCENARIO 2

**Scenario 3** contains the forward fuselage, seat rows 1 to 10, which was subjected to the impact and was not fire damaged. The scenario contains 2 crew and 55 passengers. Two passengers in this scenario sustained serious fire injuries in the accident. It is assumed that the injuries were caused by fire outside the cabin during the evacuation.

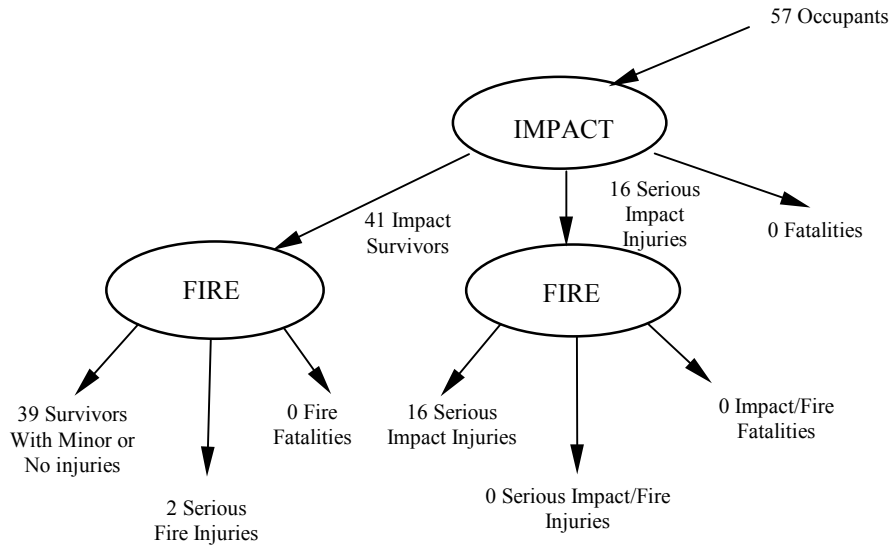

### SCENARIO 3

**Scenario 4** contains the mid-forward section, seat rows 11 to 19, which was subjected to the impact and was not fire damaged. The scenario contains 72 passengers. This section contained no fire during the accident therefore it is assumed that the six occupants who sustained undetermined injuries were killed by impact. This is supported by the fact that a large number of occupants in this section were ejected during the impact. Two passengers suffered serious injuries from fire but they were located at a fuselage break, and it is assessed that either the fire spread locally across the break or they sustained injuries during egress.

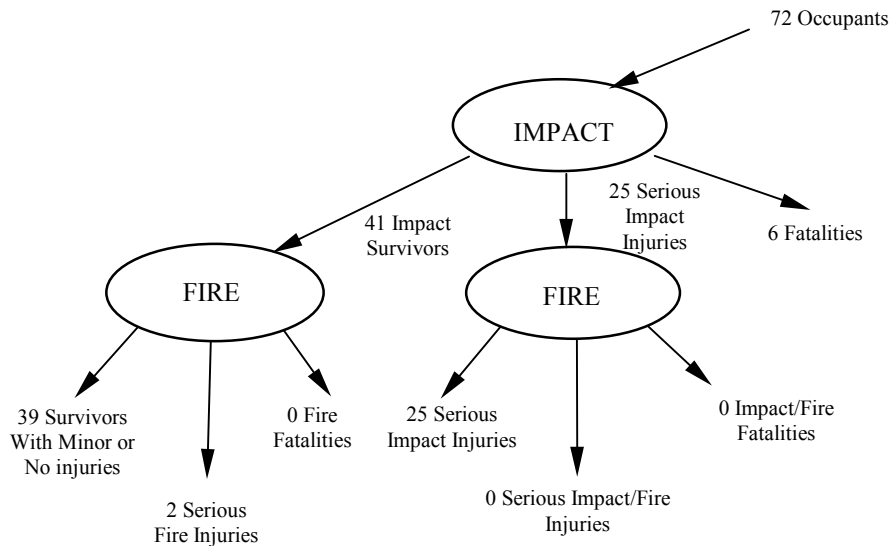

### SCENARIO 4

**Scenario 5** contains the mid-rearward section, seat rows 20 to 27, which suffered an explosion and fire after the initial impact. The scenario contains the 2 crew and 73 passengers. It was reported that some of the passengers died as the fuselage split and it is therefore assumed that 13 of the undetermined fatally injured passengers, located along the separation, were killed by impact trauma or were thrown out. Of the remaining 33 fatalities, the 2 flight attendants were known to be killed from the fireball. Of the remaining 31 undetermined fatalities it is assumed that occupants in seat rows 21 to 23 suffered impact injuries and then died from the fire, and occupants in seat rows 24 to 26 were killed by fire only.

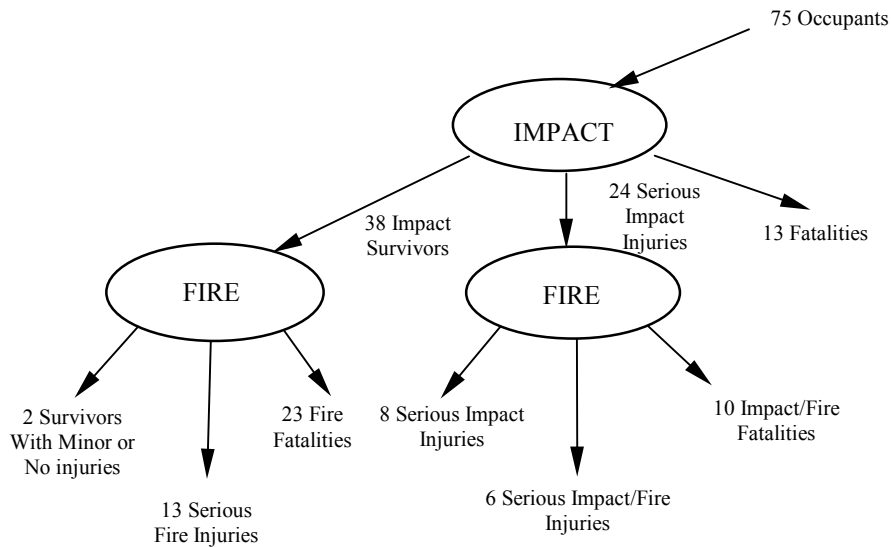

SCENARIO 5

**Scenario 6** contains the rear section, seat rows 28 to 41, and the rear flight attendant area, which was subjected to fire after the initial impact. The scenario contains 2 crew and 119 passengers. It is assumed that the two occupants seated in row 28F and G were killed by impact trauma as the fuselage split into sections.

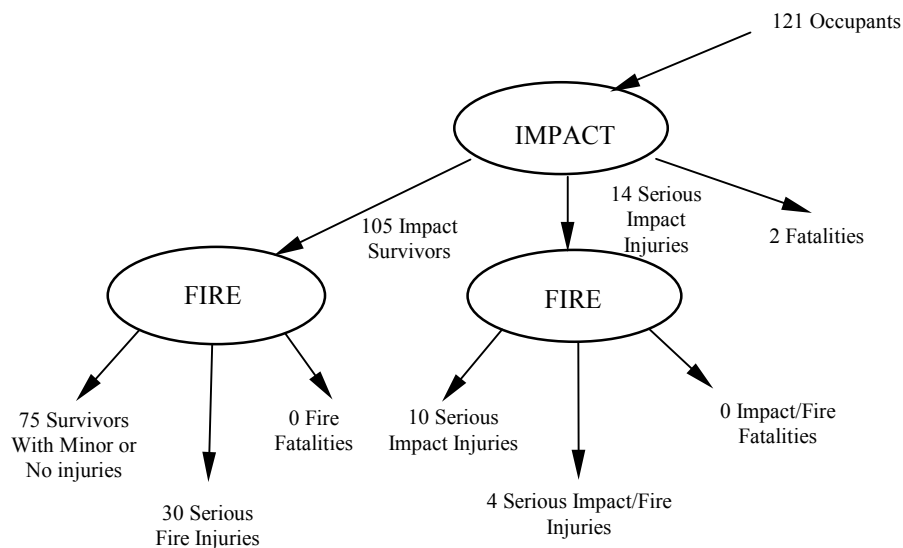

SCENARIO 6

**Scenario 7** contains the eight occupants for which seat location and injuries were unknown. Absence of information results in the following simplified survivability chain. The six unknown injuries have been assumed minor or none since they were not significant enough to be reported officially. It is not possible to determine the cause of death for the two fatalities.

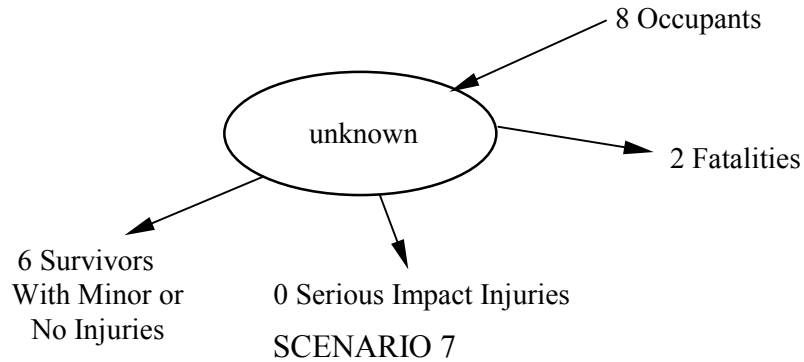

**EFFECT OF INTRODUCING 16-g SEATS**

Scenarios 1 and 2

These scenarios contain only flight and cabin crew seats therefore benefit from the introduction of 16-g passenger seats is not applicable.

Scenario 3

Statements (in the form of questionnaires) from the surviving passengers indicated that most of them were able to unfasten their safety belts and that their seats resisted the impact. This part of the fuselage rested on its left side at 70 degrees. As a result, the majority of serious injuries sustained by the occupants in this section consisted of fractured bones. It is assumed that they were thrown out of their seats.

One passenger in seat 2D sustained head wounds as a result of the impact. Therefore, if 16-g seats were installed on the aircraft, this passenger might have been saved from head injury.

The high assessment assumes there is no reduction in the number of seriously injured occupants. The low and median assessments assume one serious injury would be saved with 16-g seats.

The high, median, and low predictions of the number of impact fatalities and injuries resulting from the use of 16-g seats are:

	<b>Minor or No Injuries</b>	<b>Serious Injuries</b>	<b>Fatal Injuries</b>
<b>High</b>	41	16	0
<b>Median</b>	42	15	0
<b>Low</b>	42	15	0



It is not known whether the aircraft was configured to the latest standard of fire requirements. However, since it is considered that the fire injuries were sustained outside of the cabin, they would have no influence on the injuries sustained.

Scenario 4

This section of the fuselage was transversally ruptured due to the explosion (in scenario 5) and/or the longitudinal twisting moment of the fuselage, while the aircraft was off the runway. Statements (in the form of questionnaires) from the surviving passengers indicated that most of the seats did not resist the impact, hence a large number of occupants in this section were ejected during the impact sequence. Only about eight seriously injured passengers said that their seats had survived the impact. Some passengers reported that they were hit by loose objects, including broken seats. The majority of serious injuries sustained by occupants in this section were fractured bones and internal lesions.

Therefore, it is assessed that introducing 16-g seats would have altered the injury pattern in this scenario. The low assessment is that all six fatally injured passengers would be saved with 16-g seats. However, they would still be seriously injured by the impact. All of the seriously injured passengers, except for the in-lap infant in 17C and the eight passengers, whose seats resisted the impact, would have been reduced to minor or no injuries.

The high assessment assumes no reduction in fatalities and injuries to the occupants. The median assessment is taken as the average of the high and the low assessments.

The high, median, and low predictions of the number of impact fatalities and injuries resulting from the use of 16-g seats are:

	<b>Minor or No Injuries</b>	<b>Serious Injuries</b>	<b>Fatal Injuries</b>
<b>High</b>	<b>41</b>	<b>25</b>	<b>6</b>
<b>Median</b>	<b>49</b>	<b>20</b>	<b>3</b>
<b>Low</b>	<b>57</b>	<b>15</b>	<b>0</b>

It is not known whether the aircraft was configured to the latest standard of fire requirements. However, since the known fire-injured passengers were located at the fuselage break, the injuries were probably caused outside of the cabin area or as a result of the fuel tank explosion. On this basis it is considered that had the aircraft been configured to the latest standard of fire requirements there would be no change in the injuries sustained.

Scenario 5

It is concluded that no benefit would be gained in this scenario if 16-g seats were fitted, as almost all the fatalities are assessed to have resulted from the fire rather than impact, since there was an explosion in this area. The force of the explosion burst open the left wing (L3) emergency exit

and a number of passengers were hit by loose objects which were probably caused by the explosion.

#### Scenario 6

It is concluded that no benefit would be gained in this scenario if 16-g seats were fitted, as statements from the surviving passengers did not indicate any seat detachments in this part of the fuselage. Furthermore, a study of the survivor reports does not indicate that those seriously injured sustained head injuries. Their seats survived the impact sequence. Injuries sustained by the passengers in this section were mainly due to fire burns and loose objects.

#### Scenario 7

Due to lack of information, it is not possible to assess any benefits associated with the two fatalities for which seat location and injuries were unknown.

## ACCIDENT REF: 19930406A

Date:	06-Apr-1993	Flight Phase:	Flight
Aircraft:	MD-11	Location:	Shemya

### DESCRIPTION OF ACCIDENT

#### RESUME

On 6-Apr-1993 a China Eastern Airlines MD-11 registered as B-2171 was in cruise flight approximately 950 nautical miles south of Shemya, Alaska. The flight was a scheduled international passenger flight from Beijing, China, to Los Angeles, California, with an intermediate stop in Shanghai, China.

While in cruise flight, the aircraft had an inadvertent deployment of the leading edge wing slats. The autopilot disconnected, and the captain was manually controlling the aircraft when it progressed through several violent pitch oscillations and lost 5,000 feet of altitude. The captain regained stabilised flight, declared an emergency because of passenger injuries, and diverted to the U.S. Air Force Base, Shemya, Alaska.

The aircraft did not receive external structural damage, but the passenger cabin was substantially damaged.

There were 20 crew and 235 passengers on board. Two passengers suffered fatal injuries. Seven crew and 53 passengers suffered serious injuries. Thirteen crew and 180 passengers escaped with minor or no injuries.

#### IMPACT

The flight crew reported that the operation of the aircraft from Beijing to its intermediate stop at Shanghai was normal. They also reported that the takeoff, climb, and initial en route segment of the flight from Shanghai to Los Angeles were normal.

The aircraft had been airborne about 5 hours, and the flight attendants had completed the meal service and had dimmed the lights for a movie when the aircraft began the violent pitch oscillations.

The captain involved in the accident stated in an interview with Safety Board investigators that he was one of four members of the oncoming relief flight crew that had assumed flight responsibilities of the aircraft approximately 20 minutes prior to the event. The captain further stated that he was the flying pilot but occupied the right seat at the time of the accident because he was providing instruction to the first officer in the left seat.

At the time of the accident, the aircraft was in cruise flight at 33,000 feet (FL330), above the clouds, at an indicated airspeed of approximately 298 knots (Mach 0.82) with the No. 1 autopilot

engaged. The captain stated that they had not experienced any “unusual weather phenomenon” until approximately 15 minutes prior to the event. At that time, the aircraft encountered what he described as “light” turbulence, and he turned on the seatbelt sign. He also stated that shortly thereafter, the “turbulence increased;” however, the flight attendants and most passengers stated that the “flight had been smooth” and the seatbelt sign had been off until the initial pitch oscillation occurred.

The captain also stated that prior to the turbulence encounter, he observed a second Mach speed indication (depicted by an open circle with the speed .728) below the selected flight management computer (FMC) command speed indication (depicted by a solid circle with the speed .82) on the right side primary flight display (PFD) airspeed indicator. He said that the second Mach indication was “usually not displayed,” and that he had attempted to correct the secondary indication by momentarily engaging the autopilot speed command and then disengaging the system. However, this action was unsuccessful, so he attempted to correct the airspeed indication with inputs to the FMC through the No. 2 multifunction control display unit (MCDU). This action was also unsuccessful, and the secondary Mach indication remained visible on the airspeed indicator.

The captain also stated that when they experienced the “increase in turbulence,” he observed the white “SLAT” light with a down arrow illuminate on the PFD. In addition, he stated that the angle of attack (AOA) bars had changed colour on the PFD from cyan to red (indicating a stall condition), the stall warning stick shaker activated and, at the same time, the “slat overspeed” warning chime sounded. The captain stated that he immediately verified that the flap/slat handle was in the retracted position by pushing the handle forward and the flight engineer placed his hand on the flap/slat handle twice to ensure that the handle remained forward in the retracted position.

According to the flight data recorder (FDR) information, the aircraft was in a slow right turn (initiated by a change in selected heading) at 296 knots indicated airspeed (KIAS) with the No. 1 autopilot engaged when a slat disagree indication was recorded (slat position, pressure altitude, roll angle, and other data were not recorded by the FDR because of a prior failure within the aircraft’s digital flight data acquisition unit; therefore, values of those parameters during the accident flight are not known). The outboard ailerons began to move at this point. About 7 seconds after the slat disagree indication was recorded, the aircraft began pitching nose up despite autopilot-commanded nose-down elevator deflections (the autopilot elevator deflections were not sufficient to counteract the nose-up pitch moment induced by deployment of the slats). Three seconds later, the stall warning system activated while pitching nose up through 7.4 degrees at 296 KIAS and 1.37 g’s. One second later, the aircraft reached a maximum nose-up pitch attitude of 9.5 degrees, the airspeed decreased to 293 KIAS, and the vertical acceleration peaked at 1.50 g’s. The aircraft then began to pitch nose down.

After a nose-down pitch rate was established, the elevators began moving in the nose-up direction. Approximately 2 seconds later (about 13 seconds after the slat disagree indication), as the nose-down pitch rate was decreasing and vertical acceleration began to increase, the FDR recorded a rapid movement of the elevators in the nose-down and then nose-up directions,

followed immediately by deactivation of the stall warning system and disengagement of the No. 1 autopilot. The aircraft reached 5.6 degrees nose-down pitch at 286 KIAS and -0.29 g's, and then it started to pitch nose up.

The aircraft completed a second (during which another stall warning occurred), third (during which the slat disagree indication deactivated), and fourth pitch oscillation over the next 13 seconds. The maximum and minimum pitch attitudes became increasingly nose down during the oscillations, reaching a maximum of 24.3 degrees nose down at the bottom of the fourth oscillation. Vertical acceleration oscillated divergently (increasing amplitude) during the second and third pitch oscillations, reaching peak values of +1.53 g's and -1.24 g's during the third, and then began to converge during the fourth as airspeed increased through 320 KIAS.

After completing the fourth pitch oscillation, nose-up elevator deflection and vertical acceleration began to increase rapidly. The FDR data became unrecoverable at this point for undetermined reasons. The FDR data once again became recoverable approximately 5 seconds later with the aircraft pitching through 15 degrees nose down, vertical acceleration decreasing through +2.0 g's, and airspeed still increasing through 337 KIAS.

The aircraft then began to pull out of its oscillating descent (reported by the crew to have ended at approximately 28,000 feet) with pitch attitude steadily increasing and the pitch and vertical acceleration oscillations damping considerably as a result of smaller (although still oscillating) elevator deflections. An overspeed warning was recorded by the FDR as the aircraft was pulling out with airspeed increasing through 348 KIAS. Airspeed peaked at 364 KIAS before beginning to decrease, and the overspeed warning deactivated as the airspeed decreased through 360 KIAS. Pitch attitude stopped increasing at approximately 7 degrees nose up and oscillated between 5 and 8 degrees nose up as it climbed. The No. 2 autopilot was engaged approximately 30 seconds later (94 seconds after the initial slat disagree indication), after which the elevator position, pitch attitude, and vertical acceleration oscillations stopped. The aircraft continued its climb and then levelled out (at FL330 according to the crew). The FDR indicates that the aircraft maintained stabilised flight during the remainder of the flight to Shemya.

Prior to the accident, the radio operator was providing position reports to the Honolulu Aeronautical Radio Incorporated (ARINC) communication specialist, who, in turn, transmitted the aircraft's position to the Oakland Air Route Traffic Control Centre (ARTCC).

At 01:23, the Honolulu ARINC communications specialist received a request from flight 583 for a deviation to the nearest airport because of an emergency. One minute later, he reported that the emergency was due to a "sick passenger." At 01:25, the radio operator again contacted the Honolulu ARINC and reported that there were injured passengers onboard due to "severe turbulence," and he declared an emergency. Through ARINC, the Oakland ARTCC controller then issued a clearance for flight 583 to divert to Shemya.

The aircraft remained airborne for approximately 2 hours after the accident, and the flight crew dumped fuel en route to reduce the aircraft's landing weight. At 03:29, an uneventful instrument landing system (ILS) approach and landing were made at Shemya.

The aircraft was configured for a 4-person flight crew in the cockpit and 14 flight attendant seats throughout the passenger cabin. There was no damage to any of the flight crew or flight attendant seats or seat restraint systems.

The passenger cabin was configured for 46 business and 294 coach class seats.

The primary damage occurred to the interior structure and seats in the coach class section. The damage to the passenger seats ranged from slight deformation to distortion and/or complete collapse of the seat arm rests and seat backs.

Several passenger service units (PSUs) in the coach class section sustained impact damage when they were struck by passengers. The damaged PSUs had been displaced or pushed up into their mounting structure. Twenty oxygen masks, in various parts of this cabin section, were found deployed as a result of damage to the PSUs.

Numerous ceiling panels in the forward coach cabin and all of the ceiling panels in the aft cabin of the coach section were damaged, and some were displaced upward against their support frames. About 80 percent of the ceiling cross beams, which support the ceiling panels in the aft section of the aircraft, were found crimped, separated, or bent.

There were 12 video monitors installed above the two aisles throughout the passenger cabin. Each monitor weighed approximately 42 pounds and was suspended from the ceiling with vertical and longitudinal support tubes. None of the 12 video monitors were damaged. However, seven of the monitors, located in the mid and aft cabins, had bent vertical and longitudinal support tubes, and rod ends were found separated from their respective support tubes. The damage to the support structure for these seven monitors was the result of upward impact forces which exceeded the design limits.

There were several first aid kits found on the aircraft. One kit was found empty, stowed in an aft overhead stowage bin. A second kit, also found empty, was on the floor near the L4 flight attendant jumpseat. The used contents of the medical kits were found in the cabin during the postaccident examination.

#### FIRE

There was no fire.

#### EVACUATION

There were 8 flight crew, 12 cabin crew, and 235 passengers on board. The flight crew consisted of the captain, the first officer, the flight engineer, and the radio operator. There was also a 4-person international relief flight crew.

The aircraft was configured with 340 passenger seats.

(Although there was no evacuation associated with this accident, the actions of the occupants during the pitch oscillations follow.)

The circumstances that precipitated the pitch oscillations were such that a prewarning to the flight attendants and passengers was not possible. Thus, it was those persons, who were unrestrained in the mid and aft cabin, who received the majority of the serious injuries.

According to some flight attendants and passengers, the “fasten seat belt” sign was not on prior to the onset of the pitch oscillations, but it did illuminate during the second oscillation.

Shortly after the pitch oscillations began, flight attendant No. 5, who was assigned to the forward left cabin door (2L), rushed forward to catch the microphone, but she was heavily pressed against the floor. At the same time, two flight attendants in the front cabin and a flight attendant in the rear cabin instinctively shouted, “turbulence fasten seat belt.” Flight attendant No. 5 then made an announcement over the public address system, “turbulence occurred due to unsteady airflow, please fasten your seat belts and do not use washrooms.”

Passengers reported that it was difficult to hear the public address announcements during the normal portion of the flight and that following the upset, it was “impossible” to hear the announcements. Also, after the upset, the predeparture safety demonstration video, without audio, was shown approximately three times. However, according to a passenger, “everyone ignored it as they usually do.” During the postaccident examination of the cabin, two portable megaphones that were operational were found stowed in the overhead bins above seats 1A and B and 47A and B.

Passengers described the pitch oscillations as a series of two or three cycles in which unrestrained passengers were alternately lifted to the ceiling and dropped to the floor, or aisle, or into seats other than those they had originally occupied. Passengers also reported striking the ceiling, armrests, seats, and/or other passengers during the oscillations.

Several overhead storage bins in the mid and aft cabins opened during the upset. A passenger, seated in 18B, stated that one of the overhead bins that opened had been “stuffed” before departure and that the flight attendant “had to pound on the bin’s door with her fist” to close and secure the bin. Other passengers said that luggage fell from overhead storage bins in the mid and aft cabins during the upset, striking several people.

Two passengers reported that flight attendants provided them with oxygen following the upset. A third passenger, who also received oxygen, stated that the two oxygen bottles given to him by a flight attendant did not operate properly and that a third oxygen bottle was empty. Another passenger expressed concern that several passengers were smoking while oxygen was being administered. Several passengers reported that a Chinese physician assisted injured persons following the upset.

Examination of the passenger cabin at Shemya after the accident revealed provisions for 16 portable oxygen bottles. Two of the bottles were stowed in the overhead bin at row 1A and B

and were found fully charged. A third bottle, found unsecured in the stowage compartment under the flight attendant seat at the L4 door, held a charge of 1,200 pounds per square inch. Nine bottles were found stowed empty. It could not be determined whether the required number of oxygen bottles was on the aircraft at the time of the accident.

The U.S. Air Force, Coast Guard, and Navy provided several aircraft to evacuate injured persons to four hospital facilities in Anchorage. The crewmembers and passengers who were not injured remained in Shemya for approximately 30 hours before they were transported to Anchorage by a second China Eastern Airlines MD-11 that was dispatched after the accident.

The crewmembers and passengers released from the Anchorage hospitals joined the uninjured persons on the second China Eastern aircraft, and the flight continued on to Los Angeles.

#### AIRCRAFT FACTORS

The aircraft was a McDonnell Douglas MD-11 registered as B-2171 and operated by China Eastern Airlines.

The aircraft was configured with 340 passenger seats. The flight deck was configured for a 2 pilot flight crew and 2 jumpseats.

The aircraft was manufactured as serial number 48495, fuselage number 461.

The cabin was fitted with four passenger entry doors along each side. One of which was located above the wing.

#### ENVIRONMENTAL CONDITIONS

The accident occurred during the hours of darkness.

According to forecast charts, satellite photographs, and meteorological information, including pilot reports, no evidence of turbulence was forecast or present in the geographical area where the accident occurred. Additionally, the passengers and flight attendants stated that the flight had been “smooth” just prior to the pitch oscillations. The FDR data were also consistent with flight in undisturbed air.

#### INJURIES TO OCCUPANTS

There were 8 flight crew, 12 cabin crew, and 235 passengers on board. Two passengers suffered fatal injuries. Three flight crew, 4 cabin crew, and 53 passengers suffered serious injuries. Ninety-six passengers suffered minor injuries. Five flight crew, 8 cabin crew, and 84 passengers escaped with no injuries.

One male passenger succumbed to fatal injuries before the aircraft landed at Shemya, and a second male passenger died in an Anchorage hospital 1 week after the accident. Both passengers



had sustained severe head injuries. A total of 149 passengers received injuries, ranging from minor abrasions and contusions to spinal fractures, rib fractures, and life threatening head injuries, including one passenger who was paralyzed. The most serious injuries occurred to unrestrained passengers who were located in the aft cabin.

Three flight crewmembers and four flight attendants also received serious injuries, including one flight attendant who sustained severe brain damage.

### **ACCIDENT SCENARIOS AND SURVIVABILITY CHAINS**

Due to the lack of information on occupant location during the event, the aircraft has been considered as one scenario containing all occupants.

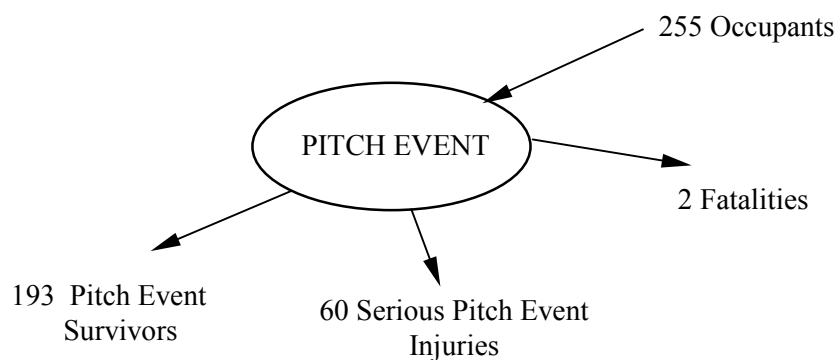

SCENARIO 1

### **EFFECT OF INTRODUCING 16-g SEATS**

From the data available to the analysts, it is believed that the seats fitted to this aircraft did not meet the 16-g criteria. The following analysis is based on this assumption.

Since the actual injuries to each occupant are not known, it is difficult to assess the number of occupants with head injuries that were caused by the seatbacks. However, a number of passengers did strike their heads on the seatbacks.

The accident report stated that the majority of the injured passengers were seated with either unfastened seatbelts or they were standing in the aisles in the aft section of the aeroplane. During the pitch oscillations, some of these people were thrown upward and downward from their seats several times, striking the overhead ceiling panels, overhead compartments, seatbacks, armrests, and/or other passengers.

On this basis, it is assumed that 60% of the passengers were not in their seats and hence any additional protection incorporated into the seats would not affect their chances of being protected from injury. The accident report also states that: *“The most serious injuries occurred to unrestrained passengers who were located in the aft cabin.”* Therefore, it is assessed that it is most likely that there would be no reduction in the number of fatal injuries had the aircraft been configured with 16-g seats.

The high assessment assumes there is no reduction in the number of fatally and seriously injured occupants.

The best assessment (low) is based on there being no fatalities and a reduction of 60% in the number of serious injuries had 16-g seats been installed. This assumes that both fatalities were to passengers that were in their seats with seat belts fastened and that their injuries may have been ameliorated had the seats been configured to the 16-g standard.

The high, median, and low predictions of the number of impact fatalities and injuries resulting from the use of 16-g seats are:

	<b>Minor or No Injuries</b>	<b>Serious Injuries</b>	<b>Fatal Injuries</b>
<b>High</b>	<b>193</b>	<b>60</b>	<b>2</b>
<b>Median</b>	<b>217</b>	<b>36</b>	<b>2</b>
<b>Low</b>	<b>232</b>	<b>24</b>	<b>0</b>

## ACCIDENT REF: 19930914A

Date:	14-Sep-1993	Flight Phase:	Landing
Aircraft:	A320	Location:	Warsaw

### DESCRIPTION OF ACCIDENT

#### RESUME

On 14-Sep-1993, a Lufthansa A320 registered as D-AIPN was landing at Okecie in Warsaw, Poland.

The pilot in the left seat was subject to check but was the pilot flying at the time of the accident. The pilot in the right seat was the instructor who was in overall command of the aircraft.

Okecie tower warned the crew of windshear and so the flight crew increased the approach speed by 20 knots, in accordance with the Flight Manual. A storm front passed through aerodrome area at that time which produced a tail wind and as a result the aircraft touched down too fast. The very light touch of the runway surface with the landing gear and lack of compression of the left landing gear leg (to the extent understood by the aircraft computer as the actual landing) resulted in delayed deployment of spoilers and thrust reversers. Delay was about 9 seconds. Thus the braking commenced with delay and in a condition of heavy rain the aircraft did not stop on the runway.

The aircraft ran off the end of the runway, collided with an embankment and stopped on the other side of it. The aircraft caught fire as a result of the impact.

There were 6 crew and 64 passengers aboard. One crewmember and one passenger suffered fatal injuries. Two crew and 49 passengers suffered serious injuries. Three crew and 14 passengers escaped with minor or no injuries.

#### IMPACT

Okecie tower warned the crew of windshear and so the flight crew increased the approach speed by 20 knots, in accordance with the Flight Manual. A storm front passed through aerodrome area at that time which produced a tail wind of approximately 20 knots and as a combined result the aircraft touched down too fast.

After first contact of the right landing gear assembly with the runway the pilot attempted to use wheel brakes, and when they failed to work, demanded the right-seat pilot to assist.

Automatic systems of the aircraft depend on oleo strut compression and a weight-on-wheels switch to unlock the use of ground spoilers and engine thrust reversers. Only when the left landing gear touched the runway were these systems activated. As a result of the light and fast

landing, the operation was delayed by about 9 seconds. The systems then began to operate; the spoilers deployed to full angle (50 deg), the thrust reverser system began to work and N1 of the engines came to 71%, but the wheel brakes, depending on wheel rotation being equivalent of circumferential speed of 72 kts began to operate only after about 4 seconds.

Deceleration of the aircraft progressed in conditions of heavy rain and with a layer of water on the runway. The aircraft was decelerated with normal performance but on the last 180 metres of runway deceleration decreased by about 30%. Residual length of the runway (left from the moment when braking systems had begun to work) was too small to enable the aircraft to stop on the runway. Seeing the approaching end of runway and the embankment behind it, the pilot tried to turn the aircraft but only managed to deviate the aircraft a little to the right.

The aircraft ran off the end of runway with a speed of 72 kts and having travelled 90 metres its left wing collided with the embankment. The aircraft slid over the embankment, destroying an aerial and stopped right behind the embankment. During this stage the landing gear of the aircraft and the left engine were destroyed.

The bottom part of the fuselage up to the wing area was found significantly deformed and broken in the wing area.

The radar dome and radar antenna were found detached from the aeroplane and destroyed.

The aft part of the fuselage, from aft doors, was found complete, with minor deformation.

The left main landing gear was detached, the wheel assembly partially burnt and no pressure was found in the tyres. The right main landing gear was partially detached from the fuselage fitting but otherwise complete. Wheels and tyres were not damaged. The front landing gear detached from the fuselage but the wheels and tyres were not damaged.

## FIRE

In the collision of the aircraft with the embankment and with the aerial located on it, the fuel tanks of the aircraft were broken and the fuel began to spill on the left side of fuselage. It was most probably ignited because of contact with hot parts of the damaged left engine or with the electrical system of the aerial. It caused a fire on the left wing. The fire spread onto an area of about 600 square metres. Shortly the fire penetrated into passenger cabin, creating smoke at first and later filling the whole cabin. In 3 minutes from the emergency call, five Aerodrome Fire Service cars came to the scene. They managed to extinguish the external fire and successfully evacuated the passengers remaining in the area of danger (and blocking access for the fire services) to a safe distance.

It was impossible to stop the fire inside the aircraft. Neither the foam introduced through the open entrance nor the attempts to open the emergency exits on the left wing and to break into the cabin were successful. Eventually pouring foam through the broken-out cockpit windows gave a positive result. After 2 minutes from the beginning of the activities on the scene, the tank in the middle part of wing blew out. For the next 30 minutes extinguishing of the burning fuselage

through the hole created in the roof was continued. Fifteen minutes after the emergency call four cars of the national fire service came to the aircraft and entered into action.

Calculation of the residual fuel remaining onboard at the moment of impact and the amount drained from the wreckage indicates that about 2900 litres of aviation kerosene JA-1 was burnt in the fire, and due to action of the high temperature of oxygen bottles, about 12000 litres of oxygen was released, which obviously increased the intensity of the fire.

After the fire had been extinguished, about 6000 litres of fuel were drained from the tanks of the wreckage.

The upper part of the fuselage from the cockpit to the fin and to bottom of the passenger cabin was burnt out, including cabin furniture and equipment. The cockpit was found burnt out.

### EVACUATION

There were 2 flight crew, 4 cabin crew, and 64 passengers on board. A successful evacuation of passengers organised by the four cabin crew, in conditions of an aircraft fire, contributed to the rescue of 63 passengers of the 64 on board.

The front and aft passenger doors were found open with escape slides deployed.

During the landing, the cabin crew were seated in two pairs, one near to the front entrance and the other near to aft entrance. Only two were available to act immediately. A stewardess from the aft pair, due to breathing difficulties, fainted after opening the door and initialisation of the escape slide and was unable to take part in the further activities, and the chief steward (with injured head), who was in the front part of cabin, remained unconscious all the time during passenger evacuation. After regaining consciousness he managed to release the injured pilot blocked in the cockpit, enabling him to leave the aircraft through the open front door. But he was not able to lift the body of the instructor remaining in the cockpit.

The prompt and successful evacuation of 63 persons out of the passenger cabin during increasing smoke and intensive fire was directly due to the behaviour of the cabin crew, in spite of their injuries. The two active cabin attendants played a significant and unquestionable role preventing the panic and organising the movement of passengers to the exits.

The passenger seated in the utmost left seat in “business class” sustained a fracture of the first lumbar vertebra and of both hands. This made him probably unable to leave his seat unaided. In addition, his temporary loss of consciousness during the impact did not allow him to draw the attention of other passengers and cabin attendants.

The situation would have been significantly more severe if the injured persons needed individual direct assistance leaving the wreckage or if the type of injuries required immediate intervention, e.g., because of haemorrhage or need for reanimation. A sufficient number of ambulances did not come to the scene quickly enough and some injured were carried to the airport by casual means of transport (e.g., bus).

## AIRCRAFT FACTORS

The aircraft was an A320, registered as D-AIPN and operated by Lufthansa. The airframe was production serial number 105, manufactured in 1990 with a Certificate of Airworthiness dated 25-Apr-1990.

The aircraft carried JA-1 kerosene fuel.

At the time of the accident the tyre tread depths were low and may have been a factor in the inability of the aircraft to stop within the confines of the runway, especially in heavy rain.

The cabin was fitted with two doors at the front and two doors at the rear of the passenger cabin. In addition there were two overwing emergency exits over each wing.

## ENVIRONMENTAL CONDITIONS

The accident happened during daylight hours in windshear conditions. Wind was 150 deg at 12 kts. The ambient temperature was about 20°C.

## INJURIES TO OCCUPANTS

There were 6 crew and 64 passengers aboard. One crewmember and one passenger suffered fatal injuries. Two crew and 49 passengers suffered serious injuries. Three crew and 14 passengers escaped with minor or no injuries.

Of the 2-person cockpit crew, the left-seat pilot survived (injured by impact) and the right-seat pilot was killed outright.

The autopsy of the body in the right-seat indicates that he was killed during the impact due to collision with cockpit interior elements. It was confirmed by extensive damage to the internal organs, namely: rupture of pericardial sac and of the main artery wall, rupture of internal membrane of aorta, and perforation of the lungs with broken ribs. Presence of the carbon oxide haemoglobin or alcohol in the blood of the pilot was not stated. During examination of stomach contents and kidney neither drugs nor medicines affecting the capacity or capability to perform pilot duties were discovered.

In the blood of the fatally injured passenger 22.6% of carbon oxide haemoglobin was found, and in the opinion of the person who performed the autopsy intoxication with carbon oxide in the environment of the high temperature was the cause of the death.

The injury profile was as follows:

Twenty-one spine injuries, 8 head injuries, 8 chest injuries (broken ribs), 4 abdomen contusions, 5 broken limbs, 1 burn, and 9 others (56 in total).

## ACCIDENT SCENARIOS AND SURVIVABILITY CHAINS

The only information available regarding the location of occupants is the statement that they were uniformly distributed throughout the cabin. Therefore, this accident is considered as four scenarios, the largest encompassing the aircraft cabin occupied by all of the passengers.

This accident is divided into four separate scenarios, as shown in figure A-13.

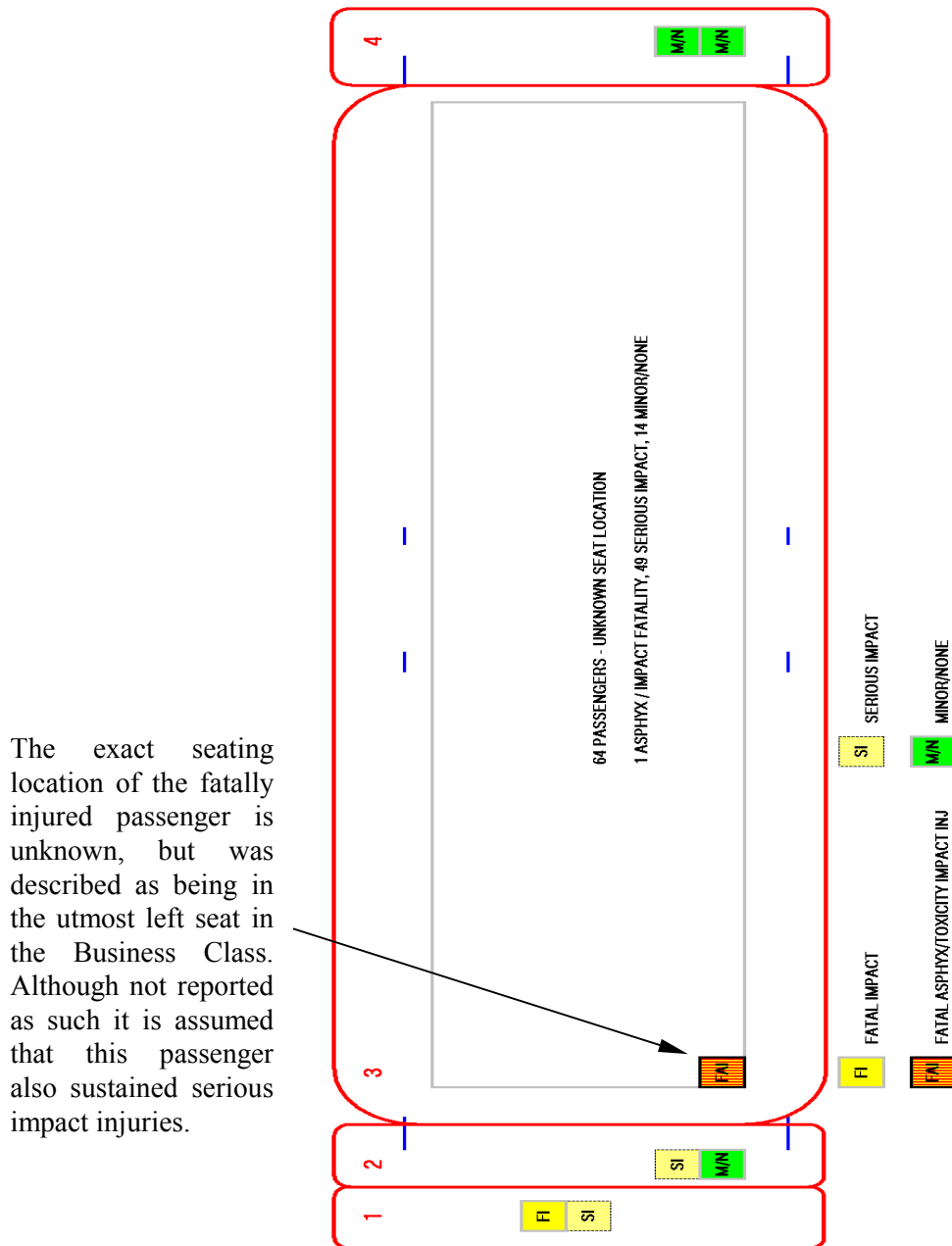
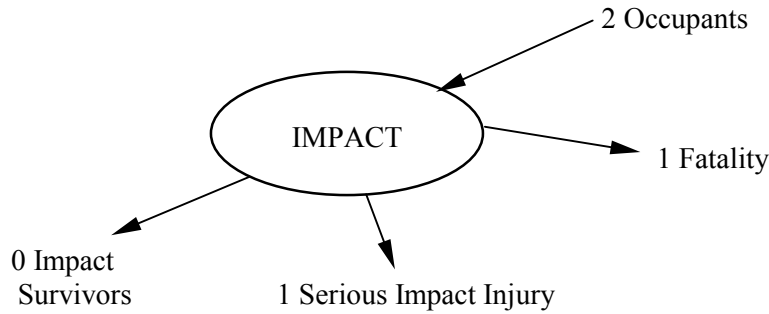

FIGURE A-13. LOCATION OF INJURIES AND SCENARIOS

**Scenario 1** contains the flight deck area where one flight crewmember died and the other sustained serious injuries from the impact.



SCENARIO 1

**Scenario 2** contains the forward flight attendant area where only the chief steward sustained serious injuries from the impact. The scenario contains two flight attendants.

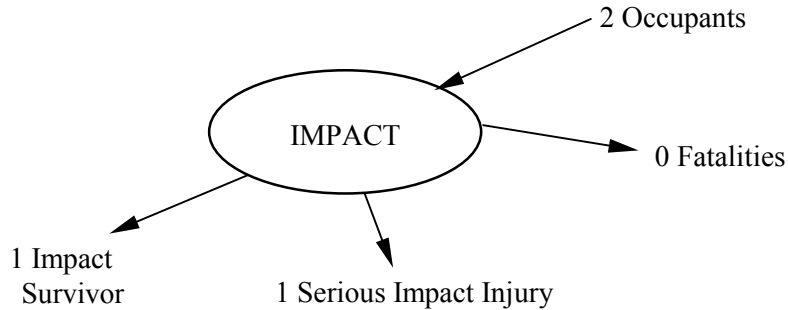

SCENARIO 2

**Scenario 3** contains the whole passenger cabin. This has been used because of limited detail on passenger locations during the accident. The scenario contains all 64 passengers. Fifty passengers received serious injuries as a result of the impact and one of these passengers died from intoxication.

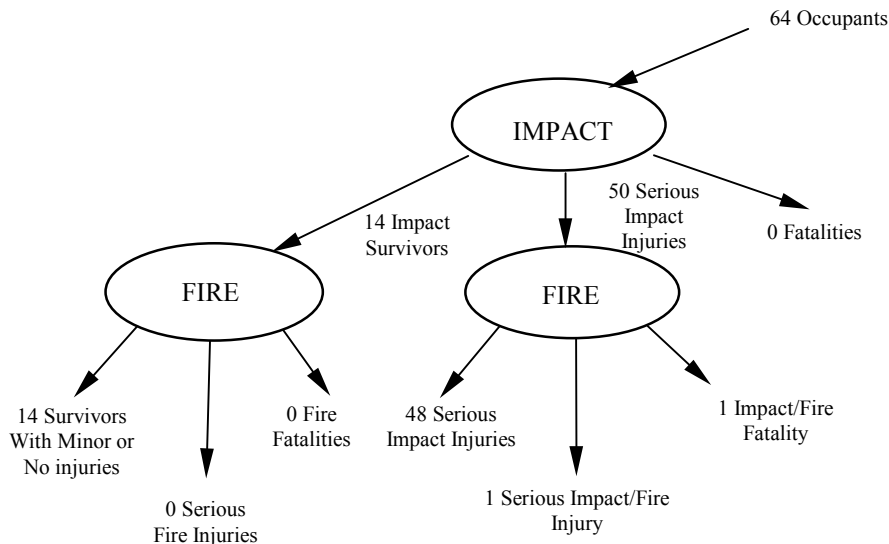

SCENARIO 3



**Scenario 4** contains the rear flight attendant area where the two flight attendants received minor or no injuries from the impact.

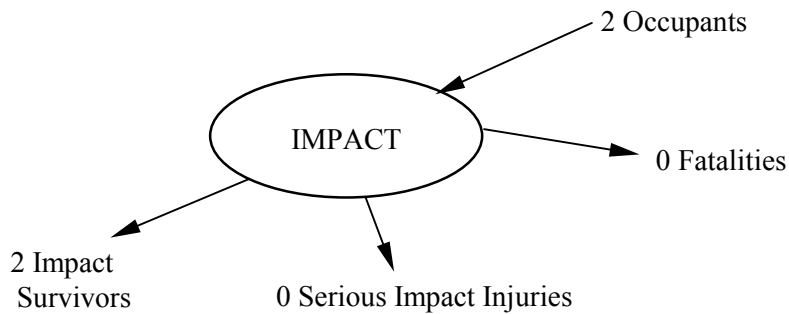

SCENARIO 4

### **EFFECT OF INTRODUCING 16-g SEATS**

#### Scenarios 1, 2, and 4

These scenarios contain only flight crew and cabin crew seats. Therefore, benefit from the introduction of 16-g passenger seats is not applicable.

#### Scenario 3

There were no reported seat detachments or seat failures in this accident. It is believed that the aircraft was configured to the latest standard of fire-related requirements (heat release, seat blocking, etc.). The fatally injured passenger seated in the utmost left seat in “business class” sustained a fracture of the first lumbar vertebra and of both hands. This probably made him unable to leave his seat unaided. On this basis, 16-g seats would not have saved this passenger from serious injuries prior to being intoxicated.

Of the 56 injuries recorded in the injury profile, there were 8 head injuries.

The low assessment assumes that head injuries were sustained by passengers and that all eight sustained no other injuries. Therefore, if 16-g seats were fitted on the aircraft they may have been saved from serious injury.

The high assessment assumes no reduction in serious injuries.

The median assessment is the average of the high and low assessments.

The high, median, and low predictions of the number of impact fatalities and injuries resulting from the use of 16-g seats are:

	<b>Minor or No Injuries</b>	<b>Serious Injuries</b>	<b>Fatal Injuries</b>
<b>High</b>	<b>14</b>	<b>50</b>	<b>0</b>
<b>Median</b>	<b>18</b>	<b>46</b>	<b>0</b>
<b>Low</b>	<b>22</b>	<b>42</b>	<b>0</b>

## ACCIDENT REF: 19940321A

Date:	21-Mar-1994	Flight Phase:	Landing
Aircraft:	DC9-32	Location:	Vigo

### DESCRIPTION OF ACCIDENT

#### RESUME

On 21-Mar-1994, a DC-9-32 registered as EC-CLE and operated by Aviacion y Comercio (AVIACO) was landing at Vigo, Spain.

The aircraft touched down about 100 feet short of the runway on the up-sloping grass runway overrun, resulting in separation of both main landing gear from their wing attachment points. The left gear came to rest on the runway. The right gear separated from the wing but remained entangled in the aircraft structure until the aircraft came to rest on the left side of the runway.

The left wing fuel tank was intact. However, overloads on the right landing gear wing rear spar attachment fitting installation produced a rupture of the right wing rear spar web which opened the integral right wing fuel tank allowing fuel to escape and feed a postcrash fire.

The 116 persons aboard the flight evacuated the aircraft. However, two persons were injured during the accident or evacuation.

### EFFECT OF INTRODUCING 16-g SEATS

The accident to the Spanish registered DC9 at Vigo was investigated by the accident investigating authority in Spain. Although the Accident Report is not currently available for analysis, an NTSB Safety Recommendation resulting from this accident states:

*“.....2 persons were injured during the accident or evacuation.”*

If it is assumed that one person was injured during the evacuation it is possible that the other person referred to could have been a passenger that sustained serious injuries during the impact sequence. However, this is considered unlikely since the NTSB Safety Recommendation also states that:

*“The 116 persons aboard the flight evacuated the airplane...”*

On this basis, it is considered that the injuries associated with this accident are unlikely to have been avoided had the aircraft been configured with 16-g seats. However, a low assessment is included, based on one serious injury being prevented.

	<b>Minor or No Injuries</b>	<b>Serious Injuries</b>	<b>Fatal Injuries</b>
<b>High</b>	114	2	0
<b>Median</b>	114	2	0
<b>Low</b>	115	1	0

## ACCIDENT REF: 19940426A

Date:	26-Apr-1994	Flight Phase:	Approach
Aircraft:	A300	Location:	Nagoya

### DESCRIPTION OF ACCIDENT

#### RESUME

On 26-Apr-1994, Airbus A-300-600R registered as B-1816 and operated by China Airlines was approaching the Nagoya/Komaki Airport, Nagoya, Japan.

The first officer was manually flying the aircraft with the autopilot off. The Safety Board believes that the first officer inadvertently selected the auto-throttle system to the go-around mode. The CVR transcript indicates that the flight crew did not understand why the aircraft was not responding to the control inputs when the autopilot was engaged and apparently did not realise that the autopilot was trimming the aircraft nose up.

As a result, the aircraft entered an aerodynamic stall at approximately 1800 feet above ground level and the pilots were unable to regain control prior to striking the ground short of the runway.

The aircraft ignited and was destroyed.

There were 15 crew and 256 passengers aboard. Fifteen crew and 249 passengers suffered fatal injuries. Seven passengers suffered serious injuries.

#### IMPACT

While crossing approximately 1,070-ft pressure altitude, the first officer inadvertently triggered the GO lever. As a result the aircraft shifted into GO AROUND mode leading to an increase in thrust.

The captain cautioned the first officer that he had triggered the GO lever and instructed him, saying “disengage it.” The aircraft levelled off for about 15 seconds at approximately 1,040 ft pressure altitude (at a point some 5.5 km from the Runway).

The captain instructed the first officer to correct the descent path which had become too high. The first officer acknowledged this. Following the instruction, the first officer applied nose down elevator input to adjust its descent path and consequently the aircraft gradually regained its normal glide path.

During this period, the captain cautioned to the first officer twice that the aircraft was in GO AROUND Mode.

Both AP No.2 and No.1 were engaged almost simultaneously when the aircraft was flying at approximately 1,040-ft pressure altitude, a point 1.2 dots above the glide slope. Both APs were used for the next 30 seconds. There is no definite record in the CVR of either of the crew expressing their intention or calling out to use the AP. For approximately 18 seconds after the AP was engaged, the Trimmable Horizontal Stabilizer (THS) gradually moved from 5.30 to 12.30, which is close to the maximum nose-up limit. The THS remained at 12.30. During this period, the elevator was continually moved in the nose-down direction.

In this condition, the aircraft continued its approach, and when it was passing about 510-ft pressure altitude (at a point approximately 1.8 km from the runway), the captain, who had been informed by the first officer that the thrust had been latched, told the first officer that he would take over the controls. Around this time, the thrust levers had moved forward greatly, increasing EPR from about 1.0 to more than 1.5. Immediately afterwards, however, the thrust levers were retarded, decreasing EPR to 1.3. In addition, the elevator was moved close to its nose-down limit when the captain took the controls.

Immediately after the captain called out “Go lever,” the thrust levers were moved forward greatly once again, increasing EPR to more than 1.6. The aircraft therefore began to climb steeply. The first officer reported to Nagoya Tower that the aircraft would go around, and Nagoya Tower acknowledged this. The aircraft started climbing steeply, angle of attack increased sharply and computed air speed decreased rapidly. During this period, the THS decreased from 12.30 to 7.40, and SLATS/FLAPS were retracted from 30/40 to 15/15 after the first officer reported “Go Around” to Nagoya Tower.

The GPWS activated Mode S warning “Glide Slope” once, and the stall warning sounded for approximately 2 seconds.

After reaching about 1,730-ft pressure altitude (about 1,790-ft radio altitude), the aircraft lowered its nose and began to dive.

The GPWS activated Mode 2 warning “Terrain, Terrain” once, and the stall warning sounded until the time of crash.

The aircraft crashed into the landing zone close to a taxiway, approximately 110 metres east-northeast of the center of the Runway

From the DFDR records, it is estimated that the aircraft stalled, then descended steeply with wildly changing roll angle, and impacted the ground.

The spot where the aircraft hit the ground was an unpaved, flat landing area. There were marks left on the ground surface that clearly identified those portions of the aircraft which had hit the ground. From the shapes of the marks and these positional relationships as well as the condition of destroyed landing gears, it is inferred that on impact, the aircraft was in a somewhat left-wing down, nose-up attitude, and was in an almost level attitude.

All of the broken landing gears had signs of compressed oleo struts with buckled cylinders, which implies that the gears received an upward thrust, and so that the aircraft had impacted the ground with all landing gears extended.

The upper portions of the forward and aft fuselage sections, along with the portion of wing that remained attached to them, tumbled to the vicinity of the irrigation ditch together with the ruptured and separated vertical tail plane and upper portion of the aft fuselage, all in broken state.

The cargo loaded on board was scattered in the area between the spot where the aircraft hit the ground and the vicinity of the irrigation ditch, and almost all ruptured seats were found near the irrigation ditch.

The fuel that had leaked from the broken LH wing when the aircraft crashed into the ground splashed over the area from the vicinity of the spot where the LH wing first hit the ground to where the center of the wing had come to rest, and fuel from the RH wing was scattered widely, together with debris of the RH wing, as far as the vicinity of the irrigation ditch.

It is estimated that among the wreckage strewn forward, by the forward-acting inertial force generated when the aircraft crashed, were items such as the fuselage section aft of the central wing section, functional components, cabin furnishings, seats, and cargo burned when the fuel ignited and were destroyed by expanding fire.

Before the investigation started, some pieces of wreckage had been moved from their original positions in order to facilitate rescue activities. At the time of the investigation, the wreckage was scattered as follows:

Due to the impact of the crash, the wreckage of the aircraft except the RH and LH wings, the vertical and horizontal tail planes, the tail section of the fuselage, and the engines was scattered over an area approximately 140 metres long and 60 metres wide to the east-northeast of the LH main landing gear's ground scar. Fragments of the destroyed skin of the nose and forward fuselage sections were strewn over an area approximately 40 metres long and 30 metres wide some 120 metres away from the LH main landing gear's ground scar to the east-northeast direction. No signs of damage by fire were found on the nose and forward sections of the fuselage. The lower skin of the fuselage center and aft sections, almost entirely fragmented, were scattered over an area approximately 40 metres wide that extended approximately 60 metres to the east-northeast from the LH main landing gear's ground scar. Other parts of the center and aft fuselage sections, except a part of the skin, were almost entirely ruined by fire. The wings ripped from the fuselage were found at a point approximately 80 metres to the east-northeast of the LH main gear's ground scar. The LH outer wing was torn from the wing, and the RH outer wing, broken into several fragments, was also separated from the wing. They were burnt and discovered near the wings and the water gate, respectively. The LH engine was torn from the wing pylon and was found near the wing and the RH engine remained barely attached to its pylon. The fan hubs of both engines were broken and detached.

The horizontal tail plane and tail cone were broken and torn from the fuselage and were found at a point approximately 30 metres to the east-northeast of the LH main landing gear's ground scar. The vertical tail plane was broken and separated from the fuselage together with the upper rear part of the fuselage. It was burnt and found over the irrigation water channel approximately 65 metres to east-northeast of the LH main landing gear's ground scar.

The entire fuselage nose section had fragmented into small pieces, except the ceiling section above the front windshield which barely retained its original form.

The bottom skin of the forward fuselage was fractured at a location between stringers 38 and 42. It was found near where the aircraft had hit the ground together with the bottom skin of the aft fuselage. The skin above that section was fractured at locations corresponding to frames 18, 26, and 40.

The bottom skin of the fuselage centre section was fractured at a location between stringers 38 and 42 but remained connected to the bottom skin of the aft fuselage. Almost the entire center section of the fuselage was destroyed by fire except a portion of the side skin.

The aft fuselage section was almost entirely destroyed by fire except a part of the right-hand side skin.

The tail was fractured at locations corresponding to frames 72 and 92 with the vertical stabilizer attached to it. It was partly burnt and was found in the irrigation water channel. The upper joints of the tail section had separated. The APU compartment was damaged at its bottom with the APU still inside and was found partly overlapping the THS. The bottom skin was fractured at a location corresponding to frame 78 and was found together with fragments of the other bottom skin near where the aircraft had hit the ground.

## FIRE

Scorch marks of fire approximately 50 metres long and 20 metres wide were detected on the ground, each extending to the east-northeast from the vicinities of the ground scars of the LH and RH wing flap tracks, and the trees near the water gate were burnt. Signs of fire were also detected on the ground near where the wings were found.

The aircraft had fragmented into pieces, losing its original shape so badly that the only way to distinguish the wings was by identifying the vague shape of the engines.

It is estimated that among the wreckage strewn forward by the forward-acting inertial force generated when the aircraft crashed were items such as the fuselage section aft of the central wing section, functional components, cabin furnishings, seats, and cargo burned when the fuel ignited and were destroyed by expanding fire.

Fire broke out, and flames as high as a three-storied building enveloped an area more than 100 metres wide. Booming sounds were heard three times at intervals.



Going into action immediately, the Fire Fighting Platoon, staying clear of widely scattered aircraft fragments, advanced to about 20 metres from the wing and discharged fire extinguishing agents.

A chemical fire vehicle, a water tank truck, and a ladder truck from the Fire Fighting Headquarters of Nishikasugai County East Fire Fighting Association plus two chemical fire vehicles and two water tank trucks from the Kasugai City Fire Fighting Headquarters arrived at the crash site and went into action. Flames under the wings, however, did not abate easily.

A second party dispatched by the Fire Fighting Platoon, consisting of two chemical fire vehicles, one water supply truck, one ordinary fire vehicle, one cargo truck, and so on arrived at the site. They backed up the chemical fire vehicles that had arrived earlier and provided them with additional water and fire extinguishing agents.

A chemical fire vehicle and a water tank truck from the Komaki City Fire Fighting Headquarters arrived at the crash site and joined the fire extinguishing activities.

Later, a chemical fire vehicle from the Nagoya City Fire Fighting Bureau arrived at the site and also joined the fire fighting activities.

Aircraft components smouldering near the irrigation water channel were cut open with axes and tobiguchi (fireman's hooks) and sprayed with agents and water. The fire was finally extinguished about 1.5 hours after the initial crash.

#### EVACUATION

There were 2 flight crew, 13 cabin crew, and 256 passengers (including 2 infants) aboard.

Due to the severe nature of the impact and destruction of the fuselage volume, an evacuation was not carried out.

#### AIRCRAFT FACTORS

The aircraft was an A300B4-622R registered as B-1816 and operated by China Airlines.

The aircraft was manufactured on 29-Jan-1991 and was operating under a Certificate of Airworthiness dated 5-Jan-1983 and valid until 15-Jan-1995.

The aircraft was carrying JET A-1 fuel and the lubricating oil was Esso Turbo Oil 2380 (MIL-L-23699).

The cabin was fitted with two type I exits both sides in front of the wing and two each side behind the wing (a total of eight doors).

## ENVIRONMENTAL CONDITIONS

The synoptic weather announced by the Nagoya District Weather Service Center of the Meteorological Agency on April 26, 1994, was as follows:

A region of high atmospheric pressure centred above the Korean Peninsula and the East China Sea covered almost all of Japan. Meanwhile, a front associated with a low-pressure system hovered above the ocean to the south of Japan, and another low-pressure system was centred over the ocean to the northeast of Hokkaido. Thus, the weather was fine throughout the country except on the Pacific side of eastern Japan and northern Japan where it was cloudy.

A weather observation made shortly after the accident gave the following information: wind 290 deg at 6 knots, temperature 20°C, and visibility 20 km.

## INJURIES TO OCCUPANTS

There were 15 crew and 256 passengers aboard. Fifteen crew and 249 passengers suffered fatal injuries. Seven passengers suffered serious injuries.

The captain's body had open wounds running from the right shoulder to the right breast.

Open wounds were also found from the left breast to the left abdomen of the first officer's body, and his stomach and intestines were damaged.

Open damage was barely noticeable on the breast and abdomen of the purser's body.

Of the 271 persons aboard (256 passengers and 15 crewmembers), 16 passengers were taken to hospital by ambulance. Six of them were pronounced dead on arrival at the hospitals. The cause of death of four of the six was whole-body contusion and fractures; the other 2 died of whole-body contusion and thermal injuries. It is estimated that four out of the six were seated in the forward section of the cabin and the other two in the aft section.

In addition, three passengers died after hospitalisation, on April 27, April 28, and May 1, respectively. The cause of death of these three was whole-body contusion and fractures. The estimated seat assignments for two of the three were in the forward section of the cabin and one in the aft section.

Seven passengers survived—all of them had been seated in rows 7 through 15. Four had been in the right block of seats, two in the centre block, and one in the left block.

At the time of hospitalisation, all seven survivors were suffering from traumatic shock to various degrees. Various external wounds, primarily bone fractures caused by the impact, were found among the survivors, the locations of which differed from one to another. According to the diagnosis, those serious injuries would take from two months to a year to heal completely. All of these seven passengers were seated in the forward section of the cabin in front of the wings.

According to the autopsy reports, a great number of the remains were bruised all over and had suffered multiple fractures caused by the impact.

Nearly half of the remains had been burnt to various degrees.

According to the postmortem report, the cause of death of those passengers who died before hospitalisation was determined to be whole-body contusion, fractures, and thermal injuries.

The positions where the passengers suffering whole-body contusion and fractures were seated extended over the whole cabin area, from the front to the rear of the cabin, while thermal injury was noted in many of the passengers who are estimated to have been seated behind the main wing where the fire started.

### **ACCIDENT SCENARIOS AND SURVIVABILITY CHAINS**

Due to the massive disruption of the aircraft no attempt has been made to divide the accident into scenarios. Figure A-14 shows the entire passenger cabin in a single scenario. There were seven survivors, all of whom sustained serious injuries as a result of the impact. All fatalities have been designated as “Fatal Undetermined” since no data are currently available relating cause of death with seat allocation.

The aircraft contained 271 occupants of which 264 died. The fatalities were as a result of a combination of impact trauma and thermal assault. The injuries sustained by the seven surviving passengers were various external wounds, primarily bone fractures caused by the impact. Since the precise cause of death is unknown for all of the passengers the survivability chain can not be constructed.



## **EFFECT OF INTRODUCING 16-g SEATS**

Due to the extent of the impact it is considered unlikely that there would be any significant reduction in the number of fatalities or serious injuries resulting from the introduction of 16-g seats. However seat failure did occur; therefore it is possible that there would be some potential for a reduction in impact fatalities in the centre section of the aircraft over the wing box.

The ensuing fire was particularly severe. The accident report states:

*“Fire broke out, and flames as high as a three-storied building enveloped an area more than 100 metres wide. Booming sounds were heard three times at intervals.”*

The degree of destruction and lack of detailed information on cause of death does not necessitate the use of the survivability chain. Hence any reduction of injuries has been assessed based on the combined threat of impact and fire.

A great number of fatalities suffered multiple fractures caused by the impact. Nearly half of the fatalities had been burnt to various degrees. Therefore, the high and median assessments are that no savings would result.

The low assessment is that the number of surviving passengers in the wing box area might have doubled from four to eight. However, as with the other surviving passengers, it is assessed that they would have sustained serious injuries.

The high, median, and low predictions of the number of fatalities and injuries resulting from the use of 16-g seats are:

	<b>Minor or No Injuries</b>	<b>Serious Injuries</b>	<b>Fatal Injuries</b>
<b>High</b>	<b>0</b>	<b>7</b>	<b>264</b>
<b>Median</b>	<b>0</b>	<b>7</b>	<b>264</b>
<b>Low</b>	<b>0</b>	<b>11</b>	<b>260</b>

## ACCIDENT REF: 19940702A

Date:	<b>2-Jul-1994</b>	Flight Phase:	<b>Landing</b>
Aircraft:	<b>DC9</b>	Location:	<b>Charlotte</b>

### DESCRIPTION OF ACCIDENT

#### RESUME

On 2-Jul-1994 a US Air DC-9-31 registered as N954VJ was executing an ILS approach to the Charlotte/Douglas International Airport, Charlotte, North Carolina. A severe convective activity existed that was conducive to microburst and windshear activity.

Shortly after initiating a go-around, the aircraft gained some altitude but subsequently descended in the heavy rain with controlled flight into the terrain, striking the ground in a field on airport property, continuing through a forest area, and finally coming to rest impacting a private residence.

The aircraft was destroyed by the impact forces and a postcrash fire.

There were 5 crew and 52 passengers on board. Thirty-seven passengers suffered fatal injuries. Two crew and 14 passengers suffered serious injuries. Three crew and one passenger suffered minor injuries.

#### IMPACT

Ground witnesses, located near the approach end of the runway, stated that they observed the aircraft emerge from the rain and clouds approximately 0.25 mile from the end of the runway on a heading that was about 45 degrees to the runway. The witnesses also stated that the rain was very intense and that the wind was blowing very hard.

The aircraft initially touched down in a grassy field located within the airport boundary fence about 2180 feet from the threshold of the runway. The right main landing gear touched first, followed by the left. The furrows made by the landing gear were followed by narrow ground scars that were consistent with the right wing flap hinges.

Pieces of aircraft wreckage were scattered throughout the debris path. The debris field contained a wooded area of trees between 500 and 800 feet from the initial impact marks.

The aircraft tailcone was located approximately midway along the debris field and in close proximity to the remnants of a small brick structure where the nose landing gear was found.

The majority of the right wing was found 90 feet beyond the tailcone and several trees had been discoloured by fuel from the ruptured wing tanks.

Two large sections of the forward fuselage, including seats from the forward passenger cabin, were crushed against three large oak trees located across a street from the private residence. This section of the fuselage contained portions of the left side skin that mated with the cockpit section of the fuselage.

An approximate 40-foot section of the forward fuselage, consisting of the cockpit, the forward galley, and the left side of the passenger cabin and forward cargo compartment, came to rest on a nearby road. The aft portion of the fuselage, including the empennage and the two engines, was the last major section of the aircraft in the debris field. This had come to rest embedded in the carport of a two-bedroom house located across the road and 1,063 feet from the initial impact ground scars.

The first large section of wreckage beyond the right wing was comprised of portions of the first class and coach cabin flooring and seats from both sides of the aircraft. Seat rows 1 through 8, from the right side of the airplane; and seat rows 3 through 8 on the left side of the airplane were found in the wreckage that had impacted two large hardwood trees.

The second section of wreckage consisted of the cockpit, forward flight attendant jumpseat, forward galley, four first-class seats from the left side of the airplane, and approximately 12 feet of the cabin floor aft of the coach cabin divider. There was no evidence of postcrash fire in this portion of the wreckage. The flight attendant jumpseat was found attached to the forward left bulkhead largely intact but loose in its mounting brackets. The cabin dividers located between the first class and main cabin were missing and only their base support brackets remained in place.

The cockpit sustained substantial deformation. The captain, first officer, and observer seats were partially detached from their anchor points. The right side cockpit floor was crushed upward and aft, and both the captain and first officer seats were resting against the lower instrument panel.

The third section of wreckage, at rest in the front yard of the residence, was comprised of the left wing and overwing fuselage area and included the seats from rows 9 through 14. The wing box structure was found relatively intact, but the cabin area over the top of the wingbox had been destroyed by fire.

The large section of the left wing, wing box, and the fuselage section over the center wing section were destroyed by impact damage and post accident fire. The left main landing gear was found separated from the wing and embedded between the side of the house structure and fuselage, and the right main landing gear was found between the empennage and the road.

The aft section of aircraft consisted of the fuselage from station 870 (between the third and fourth aft-most windows) to the attachment point of the tailcone. The empennage sustained postaccident fire damage. Powerlines and poles that were in the path of the debris were broken and/or destroyed by impact or fire. The aft section of the airplane, found embedded in the carport of the residence, included the passenger cabin area and seat rows 17 through 21. The seats in rows 17 through 19 had separated from their respective floor track mounts and were found under

the seats in rows 20 and 21 (which were intact). The fuselage tailcone area sustained impact damage along the floor, and the cabin flooring was deformed upward. The deformation prevented the tailcone door from opening. The interior area of the empennage section was not burned, although the exterior did sustain fire damage. The overhead bins and passenger service units on both sides of the cabin between rows 20 and 21 were intact. None of the other overhead bins were located.

Examination of the aforementioned portions of the wreckage did not disclose any evidence of preimpact separation or failure.

Examination of the landing gear fittings revealed that the gear was in the down and locked position at the time of impact.

### FIRE

The postaccident fire consumed the portions of the aircraft wreckage in which fuel was present. There was also evidence of flashover fire in the immediate vicinity of the debris area. The crewmembers, passengers, and ground witnesses stated that they observed fire after the aircraft came to rest in various locations around the accident site. The large portion of the empennage that had separated and contained numerous survivors was heavily damaged by fire on the exterior, but the interior cabin was not adversely affected by heat or flames.

First indication of fire along the ground track was along the right side of the fuselage track where the right wing separated. The right wing forward inboard sections were slightly burned and melted. Burned tyres stored in a block building, hit by the aircraft, were also in this area. Trees to the right side of the ground track were slightly singed to their full height (40-50 feet). The bottoms of the tree trunks were sooted on the sides. This burned pattern continued along the right side of the ground track. There was heavy sooting on the trunk of a large oak tree that was hit by the right forward section of the fuselage. The upper branches of this tree were slightly singed.

The cockpit and front left section of fuselage was unburned. The tail section that hit the house had some external sooting and melting of aluminium on the aft left side. The interior was not burned. The left wing and centre wing section from approximately rows 11 to 14 were found with the right side adjacent to the tail section's left side. There was extensive fire damage to the left wing with some sections burned away. The cabin skin in the centre wing section was missing from floor level on the left side over to window level on the right side.

Eight firefighters responded with three Aircraft Rescue and Fire Fighting (ARFF) trucks and one quick response and command truck. Several firefighters stated that at the time the equipment was dispatched, it was raining very hard.

The initial notification to the fire station did not identify any particular location of the aircraft, and thus the fire equipment had to search from the runway for a large area of smoke in order to locate the wreckage. Two of the vehicles exited the airport property through a security gate



operated by a magnetic key card. The two remaining vehicles, delayed because they could not open the gate, eventually drove through the unopened gate and continued their response to the scene.

About 4 minutes after the ARFF units arrived on scene, the local fire department arrived and firefighting efforts proceeded for approximately 5 minutes using water and 187 gallons of aqueous film-forming foam (AFFF) as the extinguishing agents. Despite a brief period of heavy rain and high winds, the fires were extinguished quickly and the rescue of trapped and injured persons commenced immediately.

### EVACUATION

There were 2 flight crew, 3 cabin crew, and 52 passengers aboard. The passengers consisted of 27 males, 23 females, and 2 female in-lap infants (younger than 24 months) who were not listed on the passenger manifest.

The cabin contained 21 rows of seats and was configured with 8 first class and 95 coach seats.

Surviving passengers occupied seats 11A, 14F, 15C, and 17E and seats in rows 18 through 21. Some of the passengers in seat rows 17 through 19 were trapped in the wreckage until they were extricated by rescue personnel, while other passengers in those rows were able to escape unassisted. Due to the destruction of the fuselage, none of the emergency exits were used during the evacuation. Occupants escaped through breaks in the fuselage.

The “A” flight attendant lifted the “C” flight attendant (who sustained an open fracture to her kneecap) from the forward jumpseat and pulled her away from the wreckage. The “A” flight attendant then ran to the tail section and further assisted in the evacuation by pulling two passengers and an 18-month-old infant from the wreckage near the right engine.

The “B” flight attendant, seated on the aft jumpseat, opened the tailcone exit door slightly; however, due to cabin deformation, the exit could not be opened fully. Further, the “B” flight attendant closed the tail cone exit door when she observed smoke in the tail cone. The flight attendant then led some passengers out of the wreckage through breaks in the left side of the fuselage.

A 9-month-old infant, who was unrestrained in her mother’s lap in seat 21C, sustained fatal injuries. The mother was unable to hold onto her daughter during the impact sequence. Seat 21C was intact and the surrounding cabin structure sustained minor deformation. Additionally, the impact forces in this area were calculated to have been within human tolerances. According to passengers, a flash fire swept through the inside of the cabin during the impact sequence; examination found no evidence of either fire or smoke impingement in this area of the cabin.

## AIRCRAFT FACTORS

The aircraft was a DC-9-31 registered as N954VJ and operated by US Air. The cabin contained 21 rows of seats and was configured with 8 first class and 95 coach seats.

The cabin was fitted with a passenger entry door at the front on the port side and a service door opposite. There were two overwing emergency exits above each wing. The rear of the fuselage was fitted with a tailcone entry door and ramp.

## ENVIRONMENTAL CONDITIONS

The accident occurred during daylight in a thunderstorm. A severe convective activity existed that was conducive to microburst and windshear activity. Visibility was 1 mile and the wind was 220° at 11 kts.

## INJURIES TO OCCUPANTS

There were 5 crew and 52 passengers on board. Thirty-seven passengers suffered fatal injuries. Two crew and 14 passengers suffered serious injuries. Three crew and one passenger suffered minor injuries.

Of the 37 passengers who received fatal injuries, 32 were the result of blunt force trauma, 4 were due to thermal injuries, and 1 was the result of carbon monoxide inhalation. Passengers seated in rows 3 through 10 sustained nonsurvivable blunt force trauma, and 10 passengers seated aft of row 14 sustained fatal blunt force injuries. The passengers who received fatal thermal- or carbon monoxide-related injuries were seated in the area directly over the wing or in very close proximity to it.

The “C” flight attendant was struck by an unknown piece of wreckage which caused a fracture of the patella.

A 9-month-old female infant, who was unrestrained in her mother’s lap in seat 21C, sustained fatal injuries. The mother was unable to hold onto her daughter during the impact sequence. The impact forces in this area were calculated to have been within human tolerances.

An 18-month-old female infant was lying across seats 18E and 18F. This infant sustained serious injuries and her mother sustained minor injuries.

# ACCIDENT SCENARIOS AND SURVIVABILITY CHAINS

This accident is divided into six separate scenarios, as shown in figure A-15.

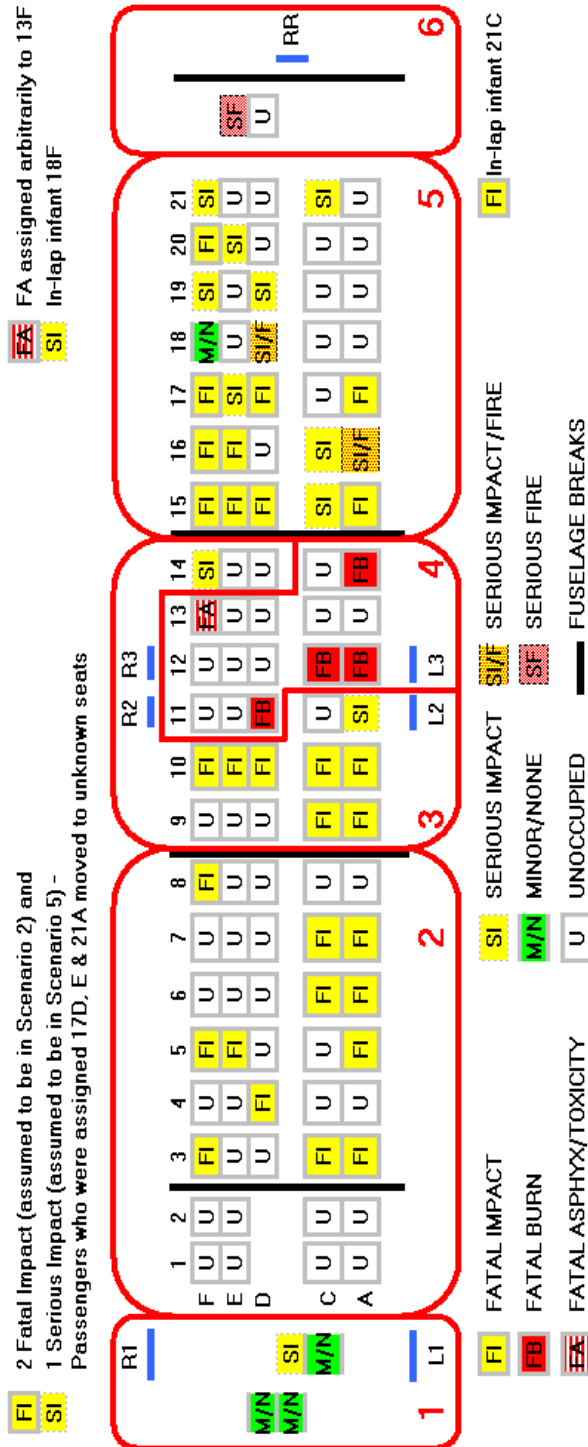
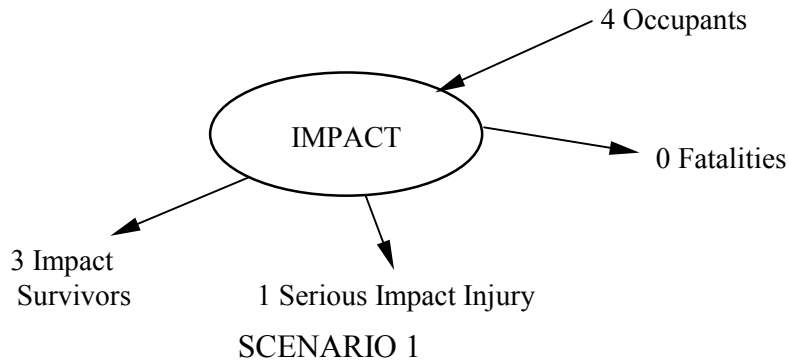
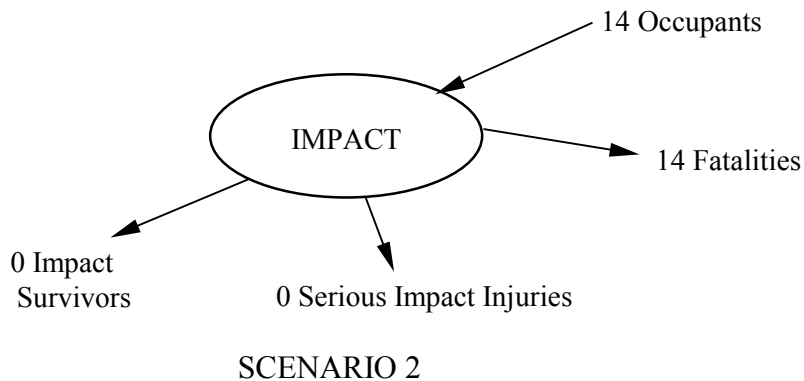

FIGURE A-15. LOCATION OF INJURIES AND SCENARIOS

**Scenario 1** represents the flight deck and the vestibule area containing two flight crew and two cabin crew. One cabin crewmember sustained serious injuries and the others received minor or no injuries in the impact.



**Scenario 2** represents the first class and part of the coach cabin area (rows 1 to 8) containing 12 fatally injured passengers. This section impacted two large hardwood trees and passenger seats were crushed against them. Due to the destruction of the fuselage in this section, it is assumed that the two impact fatalities of unknown seat location (originally assigned seats 17D and 17E) had moved to this part of the aircraft, since there were more unoccupied seats available in this section. Therefore, the total number of impact fatalities in this scenario is assessed to be 14.



**Scenario 3** represents passenger seat rows 9 and 10 and seats 11A and C and 14D, E, and F, which suffered impact damage and postaccident fire. Seven passengers suffered fatal impact injuries and two passengers suffered serious impact injuries. There were no fire injuries.

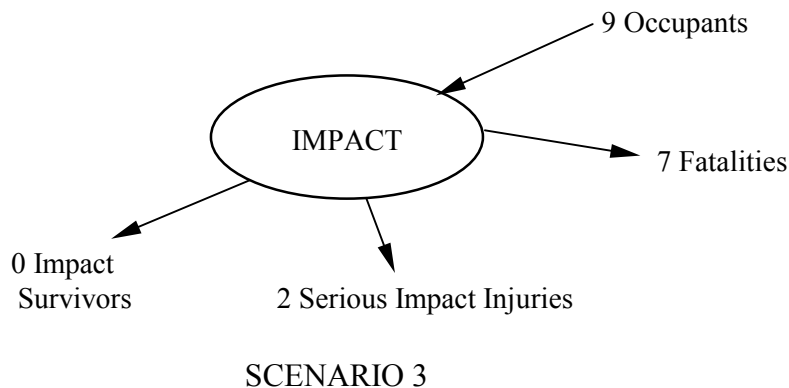

**Scenario 4** represents passenger seat rows 12 and 13 and seats 11D, E, and F and 14A and C, which suffered impact damage and postaccident fire. Five passengers sustained fatal burn injuries. No passengers were injured as a result of the impact.

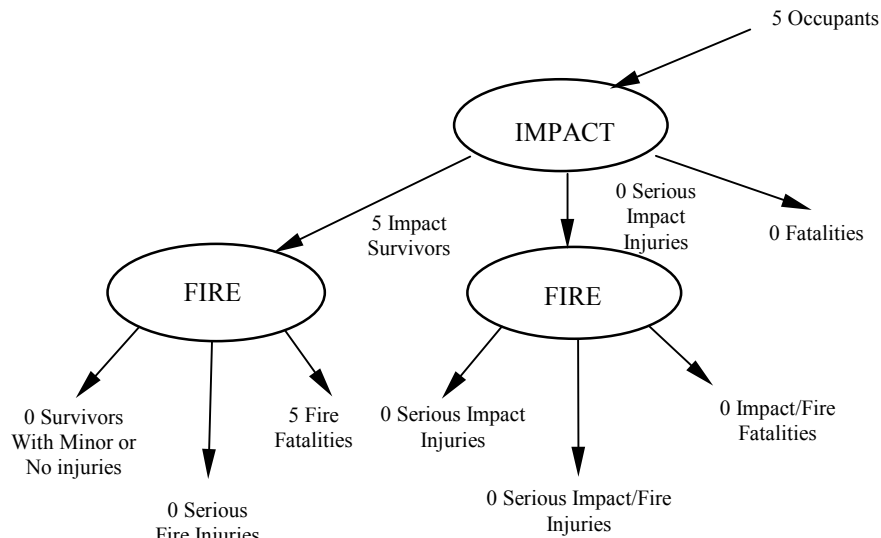

SCENARIO 4

**Scenario 5** represents passenger seat rows 15 through 21, containing 23 passengers (including 2 in-lap infants). Eleven passengers suffered fatal impact injuries, nine passengers sustained serious impact injuries, two passengers suffered serious impact and fire injuries, and one passenger received minor or no injuries. It is assumed that the passenger who suffered serious impact injuries of unknown location (originally assigned seat 21A) had moved to the unoccupied seat in 20A or 20C in front. Therefore, the total number of occupants in this scenario is assessed to be 24.

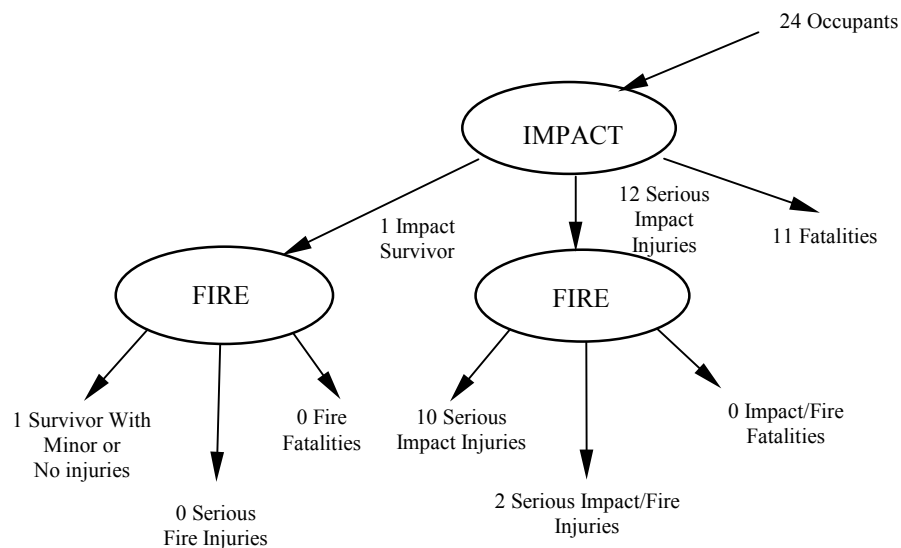

SCENARIO 5

**Scenario 6** represents the rear cabin crew area, containing one flight attendant. The flight attendant suffered serious fire burns in the accident.

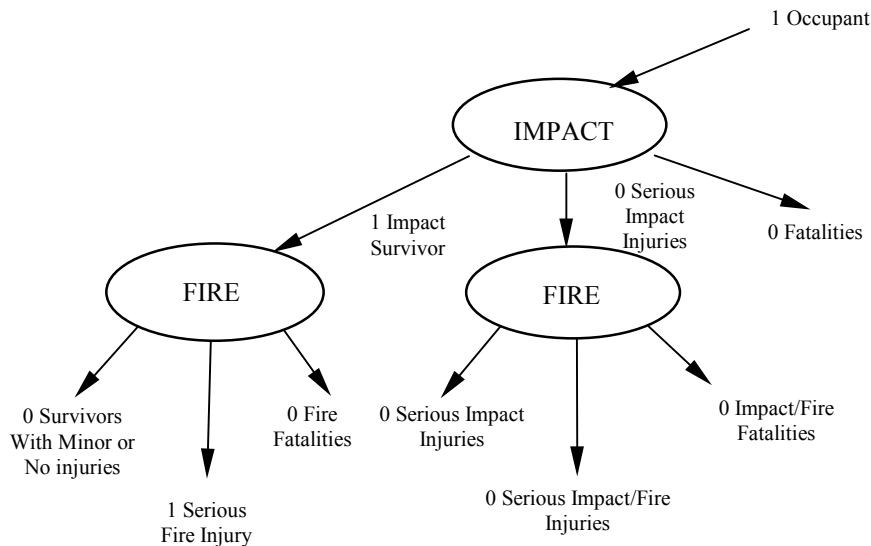

SCENARIO 6

**EFFECT OF INTRODUCING 16-g SEATS**

Scenarios 1 and 6

These scenarios contain only crew seats and therefore benefit from the introduction of 16-g passenger seats is not applicable.

Scenario 2

The passenger seats and cabin on the right side of rows 1 to 8 were detached from the main forward fuselage. Seat rows 1 to 8 from the right side of the aircraft and seat rows 3 to 8 on the left side of the aircraft had impacted two large hardwood trees. The passenger seats were crushed against the trees. Destruction to this section of the fuselage was extensive. Therefore, it is considered that no benefit would be gained from the use of 16-g seats in this scenario. The aircraft accident report stated that passengers seated in this area sustained nonsurvivable blunt force trauma.

Scenario 3

Rows 9 to 14 were extensively damaged by fire; however passengers seated in rows 9 and 10 died of nonsurvivable blunt force trauma; their seats were detached during the impact and were crushed against the trees. It is assessed that no benefit would be gained from the use of 16-g seats in this scenario.

#### Scenario 4

It is concluded that no benefit would be gained from the use of 16-g seats in this scenario since all the fatalities were as the result of fire burns/smoke inhalation, and no impact injuries were reported. Rows 9 to 14 were extensively damaged by fire.

#### Scenario 5

The fuselage in this scenario sustained impact damage along the floor, and the cabin flooring was deformed upward. Passenger seats in rows 17 to 19 separated from their respective floor track mounts and were found under the seats in rows 20 to 21 (which were intact). It is not known whether the aircraft was configured to the latest standard of fire-related requirements (heat release, seat blocking, etc.). However, passengers who suffered serious burns received their injuries as they escaped to the left side of the wreckage. Hence the fire injuries would not have been ameliorated had the aircraft been configured to these latest requirements.

Passengers in rows 15 and 16 died from blunt force.

Due to the floor damage in this area, it is assessed that introducing 16-g seats would not have saved those fatalities in rows 17 to 21. However there might be a modest saving in rows 15 and 16.

The high assessment is that no lives would be saved with the introduction of 16-g seats.

The low assessment is that all six fatally injured passengers in rows 15 and 16 would be saved with 16-g seats. However, they would still be seriously injured by the impact force. The three passengers in these seat rows that suffered serious impact injuries would be reduced to minor or no injuries.

The median assessment is taken as the average of the high and low assessments.

The high, median, and low predictions of the number of impact fatalities and injuries resulting from the use of 16-g seats are:

	<b>Minor or No Injuries</b>	<b>Serious Injuries</b>	<b>Fatal Injuries</b>
<b>High</b>	<b>1</b>	<b>11</b>	<b>11</b>
<b>Median</b>	<b>3</b>	<b>12</b>	<b>8</b>
<b>Low</b>	<b>4</b>	<b>14</b>	<b>5</b>

## ACCIDENT REF: 19951220B

Date:	20-Dec-1995	Flight Phase:	Approach
Aircraft:	B757	Location:	Cali

### DESCRIPTION OF ACCIDENT

#### RESUME

On 20-Dec-1995 an American Airlines B757-223 registered as N651AA was approaching Alfonso Bonilla Aragon International Airport in Cali, Colombia, South America.

Operating under instrument flight rules, the aircraft crashed into mountainous terrain during the descent from cruise altitude in visual meteorological conditions. The aircraft deviated from the published approach course in a valley between two mountain ridges. The accident site was near the town of Buga, 33 miles northeast of the Cali VOR. The aircraft impacted at about 8,900 feet mean sea level, near the summit of El Deluvio.

The aircraft was destroyed by the impact.

Of the 8 crew and 155 passengers aboard, 8 crew and 151 passengers suffered fatal injuries. Four passengers suffered serious injuries.

#### IMPACT

The CVR recorded the flight crew's conversations as well as radio transmissions. At 2140:40, the captain stated, "it's that [expletive] Tulua I'm not getting for some reason, see I can't get. OK now. No, Tulua's [expletive] up. At 2140:49 the captain said, "but I can put it in the box if you want it." The first officer replied, "I don't want Tulua. Let's just go to the extended centreline of uh..." The captain stated, "which is Rozo." At 2140:56, the captain stated, "why don't you just go direct to Rozo then, alright?" The first officer replied, "OK, let's...The captain said, "I'm goin' to put that over you." The first officer replied, "...get some altimeters, we're out of uh, ten now."

At 2141:02, Cali Approach requested the flight's altitude. The flight replied, "nine six five, nine thousand feet." The controller then asked at 2141:10, "roger, distance now?" The flight crew did not respond to the controller. At 2141:15, the CVR recorded from the cockpit area microphone the mechanical voice and sounds of the aircraft's ground proximity warning system (GPWS), "terrain, terrain, whoop, whoop." The captain stated, "Oh [expletive]," and a sound similar to autopilot disconnect warning began. The captain said, "...pull up baby." The mechanical voice and sound continued, "...pull up, whoop, whoop, pull up." The FDR showed that the flight crew added full power and raised the nose of the aircraft, the spoilers (speedbrakes) that had been extended during the descent were not retracted. The aircraft entered into the regime of stick shaker stall warning and nose up attitude was lowered slightly. The aircraft came



out of stick shaker warning; nose up attitude then increased and stick shaker was re-entered. The CVR ended at 2141:28.

The wreckage path and FDR data evidenced that the aircraft was on a magnetic heading of 223 degrees, nose up, and wings approximately level, as it struck trees at about 8,900 feet msl on the east side of El Deluvio. The aircraft continued over a ridge near the summit and impacted and burned on the west side of the mountain, at 3 degrees 50 minutes 45.2 seconds north latitude and 76 degrees 6 minutes 17.1 seconds west longitude. Approach unsuccessfully attempted to contact the aircraft several times after the time of impact.

The aircraft struck near the top of a mountain ridge about 35 miles northeast of Cali. The elevation of the top of the ridge was about 9,000 feet mean sea level. The aircraft initially struck trees on the east side of the ridge, and the preponderance of the wreckage, which contained the occupants of the aircraft and included both engines, came to rest on the west face of the ridge. There was no indication of in-flight fire or separation of parts before initial impact.

The initial impact area was marked by an area of broken trees, followed by a swath where the trees had been essentially flattened or uprooted. The area of uprooted trees began about 250 feet below the top of the ridge. The initial impact swath was oriented along a heading of about 220 deg. Wreckage that was found at the beginning of the wreckage path included thrust reverser parts, a fan cowling, an APU tail cone, flap jackscrews, an engine fire bottle, the FDR, and a small section of wing. The pattern of the broken trees indicated that the aircraft initially struck at a high nose-up attitude.

The main wreckage came to rest on the west side of the ridge, about 400 to 500 feet from the top. In addition to the engines, the largest portion of wreckage included the cockpit, a section of centre fuselage about 35 feet long, the CVR, avionics boxes, a section of the aft fuselage, and a portion of the wing centre section.

The wreckage evidence indicated that both flaps and landing gear were in the retracted position at the time of impact.

#### FIRE

There was no evidence preimpact fire or explosion. There was limited postimpact fire, where the main fuselage came to rest.

#### EVACUATION

There were 2 flight crewmembers, 6 cabin crewmembers and 155 passengers aboard.

Search and rescue facilities co-ordinators around the Cali and Buga area were notified of the missing flight at 21:50 local time. At 22:30, the Civil Defence, Red Cross, Police, and Army contingencies were mobilised to the Buga general area where the aircraft was last reported. The

initial sighting of the crash site was made by a helicopter at 06:30, 21-Dec-1995. Search teams arrived by helicopter to the crash site within a few minutes of the sighting.

The characteristics and magnitude of the impact and subsequent destruction of the aircraft indicated that the accident was nonsurvivable. However, five passengers initially survived the crash, having sustained serious injuries. One died later in the hospital.

#### AIRCRAFT FACTORS

The aircraft was a B757-223 registered as N651AA and operated by American Airlines.

The aircraft was manufactured as serial number 24609 and had been operated by American Airlines since 27-Aug-1991.

The cabin was fitted with four passenger entry doors along each side.

#### ENVIRONMENTAL CONDITIONS

The accident occurred during the hours of darkness.

Visibility was 10 kilometres and wind was 340 deg at 6 knots. There were rain showers in the vicinity. The ambient temperature was 28°C.

#### INJURIES TO OCCUPANTS

Of the 8 crew and 155 passengers aboard, 8 crew and 151 passengers suffered fatal injuries. Four passengers suffered serious injuries.

The body of the first officer was recovered on the first day after the accident. The body of the captain was retrieved from the crash site on the third day after the accident. The cause of death of each was determined to be blunt force trauma.

Specimens of liver, blood, and vitreous humour were obtained and analysed by the Colombian Instituto Nacional de Medicina Legal. The samples from the body of the first officer were found to be negative for alcohol and drugs of abuse. The blood and liver samples from the captain were found to be positive for alcohol at 0.074 percent and 0.35 percent blood alcohol levels, respectively, and negative for drugs of abuse. Vitreous specimens were found to be negative for both pilots.

Portions of the liver and blood samples from the bodies of the flight crewmembers were then flown to the United States to be further analysed by the Forensic Toxicology Laboratory of the U.S. Armed Forces Institute of Pathology. The analysis and subsequent re-examination of the results of the analysis in Colombia indicated that the positive alcohol level derived from postmortem microbial action, and not from premortem alcohol ingestion.

Five passengers initially survived the crash, having sustained serious injuries. One died later in the hospital.

Postmortem examination of the occupants indicated that the characteristics of the fatal and nonfatal injuries varied according to the location of the persons in the crashed aircraft. All of the injuries were consistent with deceleration trauma of different intensity consistent with the aircraft's impact and breakdown pattern. Because some passengers were found to have changed seats within the aircraft, evaluating individual injuries by seat assignment was not successful.

### **ACCIDENT SCENARIOS AND SURVIVABILITY CHAINS**

Due to the massive destruction of the aircraft, this accident was considered as a single scenario encompassing the whole cabin.

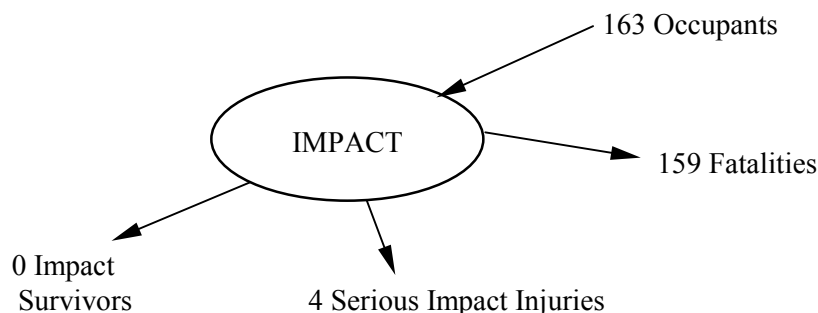

### **EFFECT OF INTRODUCING 16-g SEATS**

The characteristics and magnitude of the impact and subsequent destruction of the aircraft indicated that the accident was nonsurvivable. All of the injuries sustained for the fatal and nonfatal occupants were consistent with deceleration trauma of different intensity consistent with the aircraft's impact and breakdown pattern.

The findings of the Accident Report include the following statement:

*“Although five passengers initially survived, this is considered a nonsurvivable accident due to the destruction of the cabin.”*

Furthermore there are no recommendations in the accident report that relate to occupant survivability and no mention anywhere in the report of seat failures.

Therefore, it is assessed that the introduction of 16-g seats would not have provided any additional benefit in this accident.

## REFERENCES

1. “Proposal for Accident Data Analysis in Support of the 16-g Seat Retrofit Rule,” AIR-120, H. Jensen, 23 March 1999.
2. “Transport Controlled Impact Demonstration Seat Experiments and Cost Benefit Study,” DOT/FAA/CT-85/36, U.S. Department of Transportation FAA, October 1986.
3. “Cabin Water Sprays for Fire Suppression: Design Considerations and Safety Benefit Analysis Based on Past Accidents,” CAA Paper 93010, Civil Aviation Authority, London, 1993.

## APPENDIX B—STATISTICAL MODELLING

Software has been developed to represent a mathematical simulation of an accident using Monte Carlo Simulations. This enables assessments to be made of the likely range in numbers of survivors resulting from improvements in survivability factors.

Stage 1 of this process is shown diagrammatically in figure B-1. The in-depth analysis of accident details results in the generation of a Survivability Chain, or a series of parallel Survivability Chains for accidents with several accident scenarios. In this study, an assessment has been made of the effect on number of fatalities as a result of introducing 16-g seats. The assessment results in a prediction of the highest, mean, and lowest number of fatalities that could reasonably be expected from 16-g seats.

Stages 2 and 3 of the process are shown in figures B-2 and B-3.

Figure B-2 illustrates the principle for assessing the effect on survivability of variations in the effectivity of improvements to survivability factors. From the rationales, the “best” (or median) assessment is made of the number of fatalities and injuries that might result from the introduction of 16-g seats. However when making these determinations, the analysts will also determine a “maximum” and “minimum” number of fatalities and injuries that are likely to result.

It is then assumed that there can be 100% confidence that the fatalities will lie in the range from minimum to maximum according to the distribution shown in figure B-2. The software has been developed so that random selections may be made over the range 0% to 100% to arrive at a particular number of fatalities and injuries.

From each random selection, a re-evaluation of the number of survivors may be made using the survivability chain generated for the accident scenario as shown in figure B-3. This is then compared with the actual number of survivors of the accident. Thus improvements in survivability and hence a survivability rate may be generated. The formula employed is:

$$S_F = \frac{S - S_B}{T}$$

Where  $S_F$  = the assessment of the increase in survivability rate (or decrease in injury rate)

$S$  = the reassessed number of survivors due to 16-g seats for all accident scenarios

$S_B$  = the actual number of survivors for all accident scenarios

$T$  = the total of all occupants for all accident scenarios

Stages 2 and 3 are repeated a number of times, typically 10,000, which builds up a statistical distribution of values for the improvement in injury rate. Refer to figure B-4.

Stage 4 of the process is simply to determine the 2½, 50, and 97½ percentiles from the resulting distributions to ascertain a mean and likely range for the prediction.

Whilst it is recognised that the models are not perfect representations of an accident nor are the statistical assessments totally accurate, they will provide a better assessment of the likely impact of improvements to survivability factors than would otherwise be derived from a simple estimate of the resultant change in number of survivors.

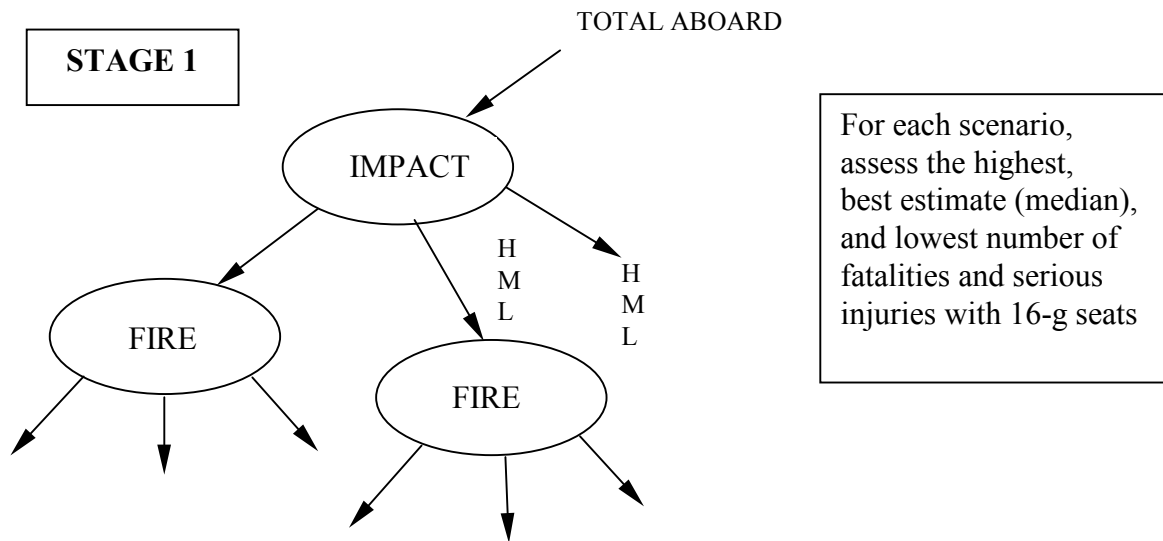

FIGURE B-1. STATISTICAL MODELLING PROCESS, STAGE 1

**STAGE 2**

Repeat stages  
2 and 3 many  
times  
(e.g., 10,000  
iterations)

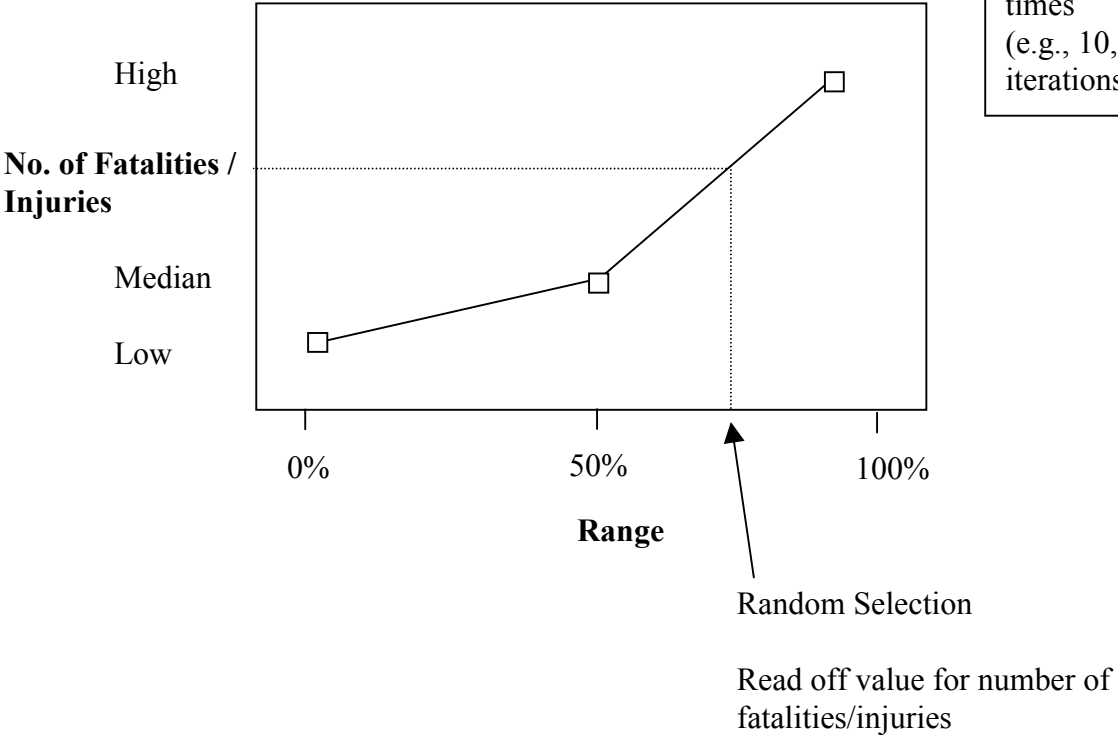
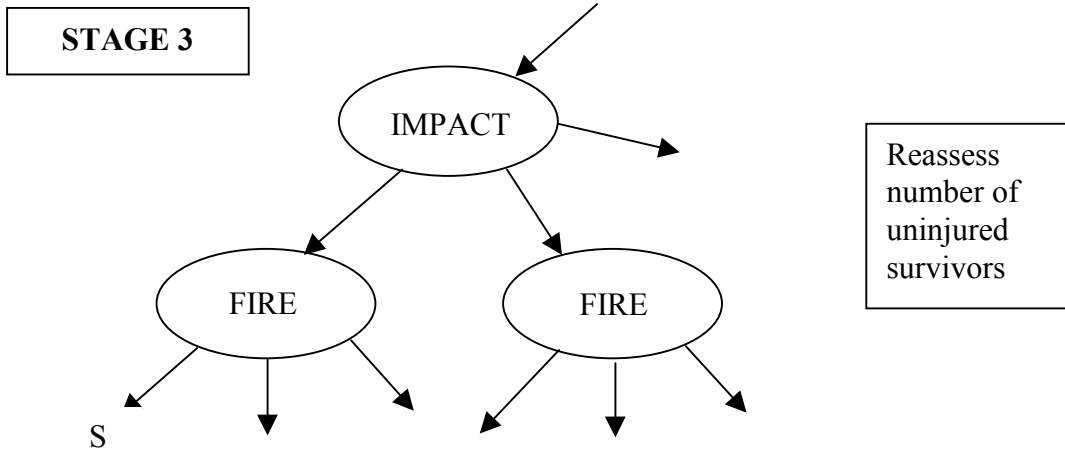

FIGURE B-2. STATISTICAL MODELLING PROCESS, STAGE 2



Evaluate injury rate improvement using:

$$S_F = \frac{S - S_B}{T}$$

Where:

$S_F$  = the assessment of the decrease in injury rate after the introduction of 16-g seats (over all accident scenarios)

$S$  = No. of uninjured survivors in all accident scenarios

$S_B$  = No. of uninjured survivors before improvements in all accident scenarios

$T$  = Total number aboard all accident scenarios

A similar technique is used for fatality rate improvement.

FIGURE B-3. STATISTICAL MODELLING PROCESS, STAGE 3



**STAGE 4**

From statistical distribution, read off 97.5, 50, and 2.5 percentiles.

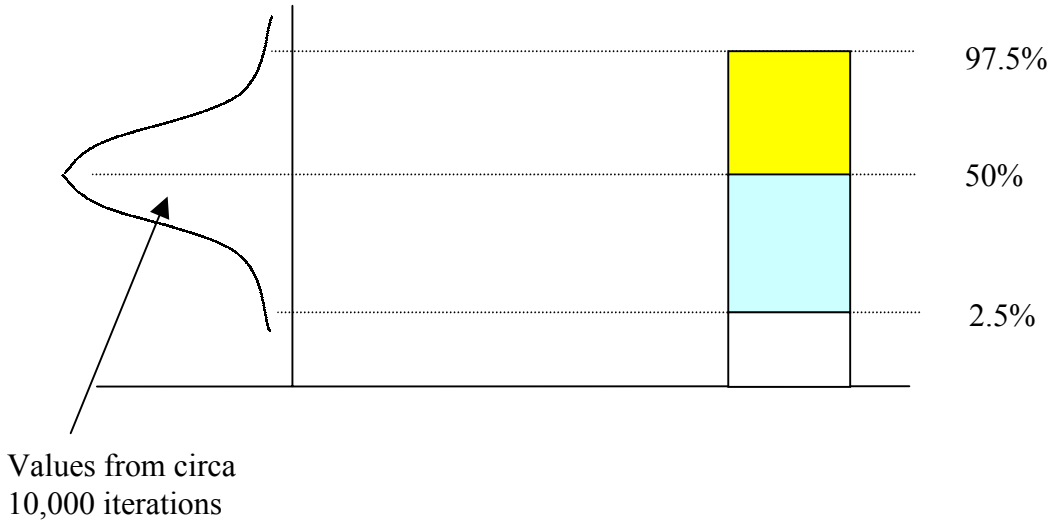

FIGURE B-4. STATISTICAL MODELLING PROCESS, STAGE 4