

Phosphazenes as Fire Retardants in Aircraft Interiors



Harry Allcock, Catherine Ambler, Jonathan Taylor,
Thomas Hartle, Clay Kellam, Robbyn Prange, Michael
McIntosh, Michael Coleman.

Department of Chemistry and Materials Science and
Engineering

The Pennsylvania State University

University Park, PA 16802

Support, FAA (Dr. Richard Lyon)



Outline

- **Why Phosphazenes for Fire Retardance?**
- **Fire-proofing Polyurethanes**
- **Block and Graft Copolymers for Fire-Resistant Blends with Commercial Organic Polymers**
 - **Block copolymers**
 - **Polystyrene with pendent phosphazene units**
 - **Fire-resistant polynorbornenes by ROMP**
 - **Cycloliner polyalkenes by ADMET**
 - **Polymers with phosphate side groups**
- **Conclusions and Future Directions**



Why Polyphosphazenes?

- **Side groups and skeletal architecture easily tailorable – wide range of properties**
- **Function through vapor and/or condensed phase fire retardance mechanisms**
- **Phosphorus plus nitrogen increases char yield**



Three Types of Phosphazene Structures for Fire Retardance

- **Cyclic, small-molecule phosphazenes covalently bonded to an organic polymer**
- **Linear, high polymeric phosphazenes**
 - **Stand-alone use**
 - **Blends with conventional polymers**
- **Block Copolymers**



Small-Molecule Cyclic Phosphazenes

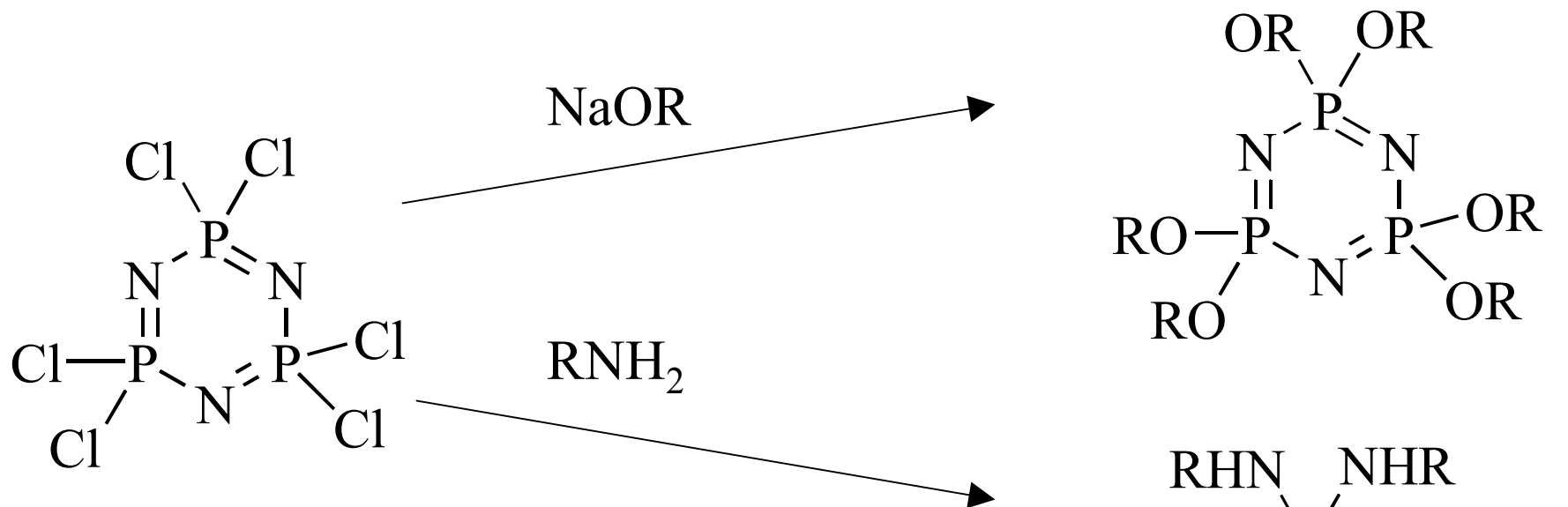

- **Highly tailorable side groups, including functional groups for linkage to organic polymers**
- **Thermo-oxidatively stable**
- **Applications include use as additives, pendent functionalities, monomers for cycloliner polymers**

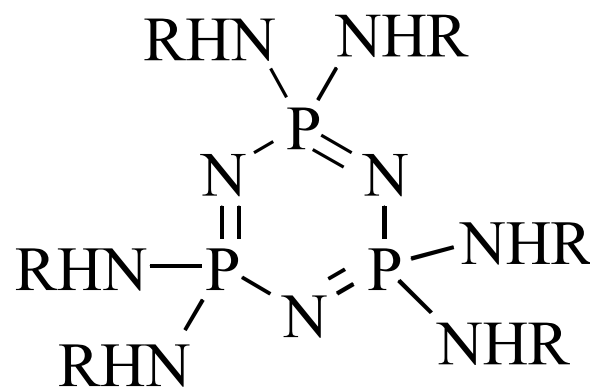



Polyphosphazene Synthesis

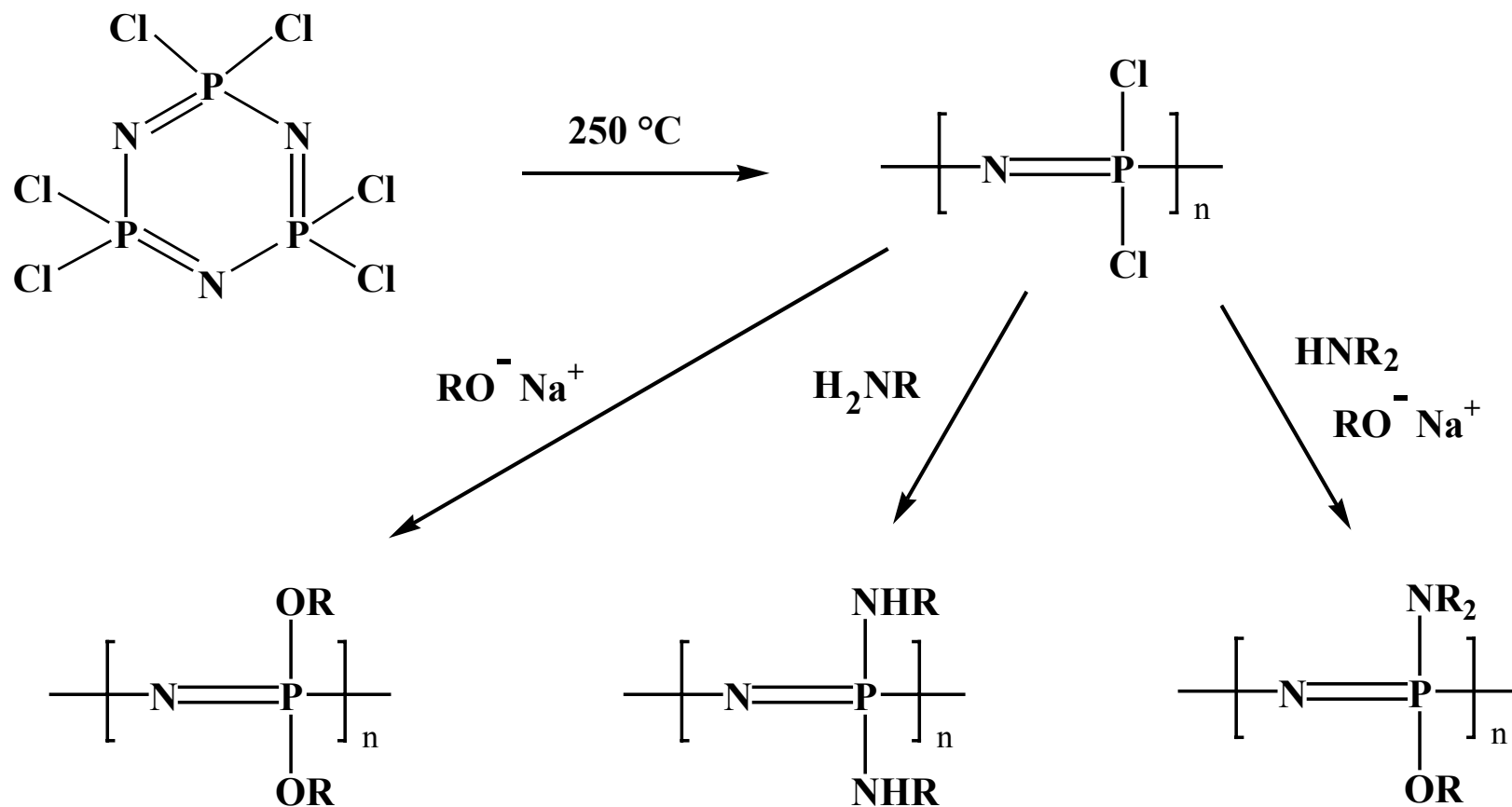



Living Cationic Polymerization

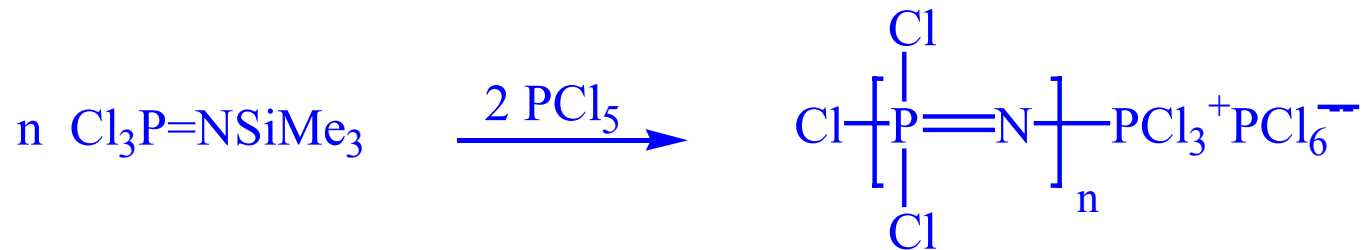

- **Polymerization of phosphoranimines**
- **Molecular weight control through stoichiometry**
- **Narrow polydispersities**
- **Undergoes macromolecular substitutions**
- **Living polymerization**
- **Allows for synthesis of blocks, dendrimers, grafts, etc**



Thermal Analysis Testing

- **Thermogravimetric Analysis (TGA)**
- **Limiting Oxygen Index (LOI)**

$$\text{LOI} = \frac{\text{O}_2}{(\text{O}_2) + (\text{N}_2)} \%$$

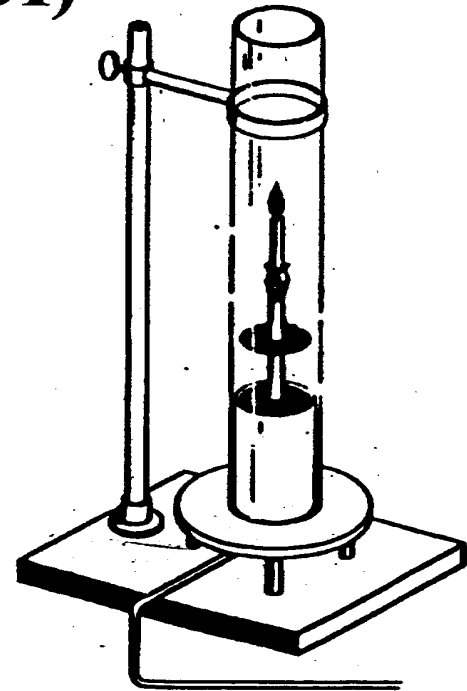



Prototype Fire Resistant Materials

Polyphosphazene

Oxygen Index (OI)

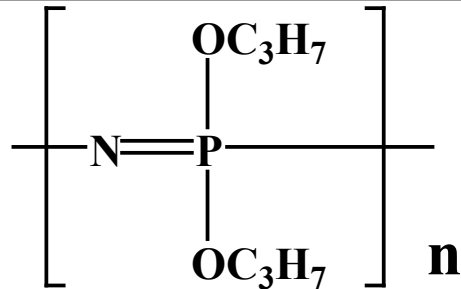

26

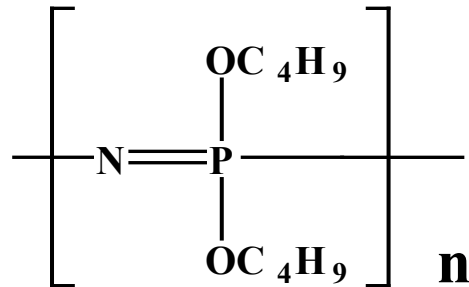

24

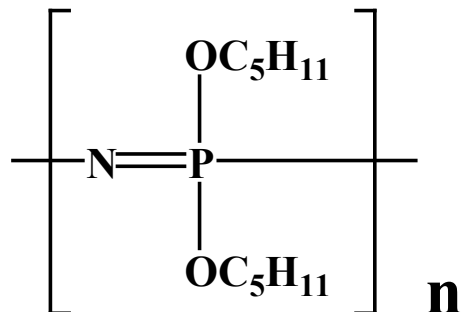

18



Prototype Fire Resistant Materials

Polyphosphazene

Oxygen Index (OI)

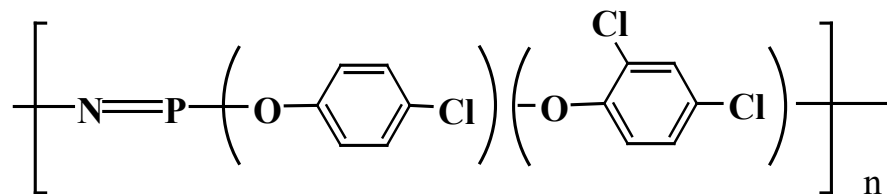

59

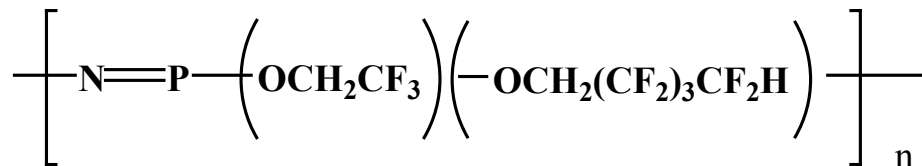

46

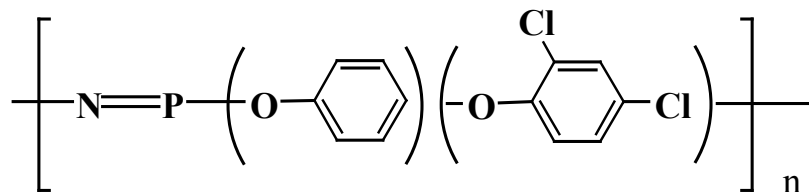

43

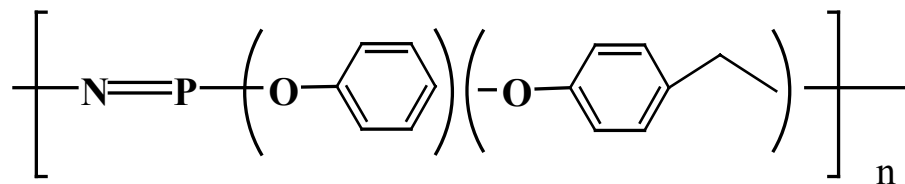

32



Phosphazene-Urethane Copolymers

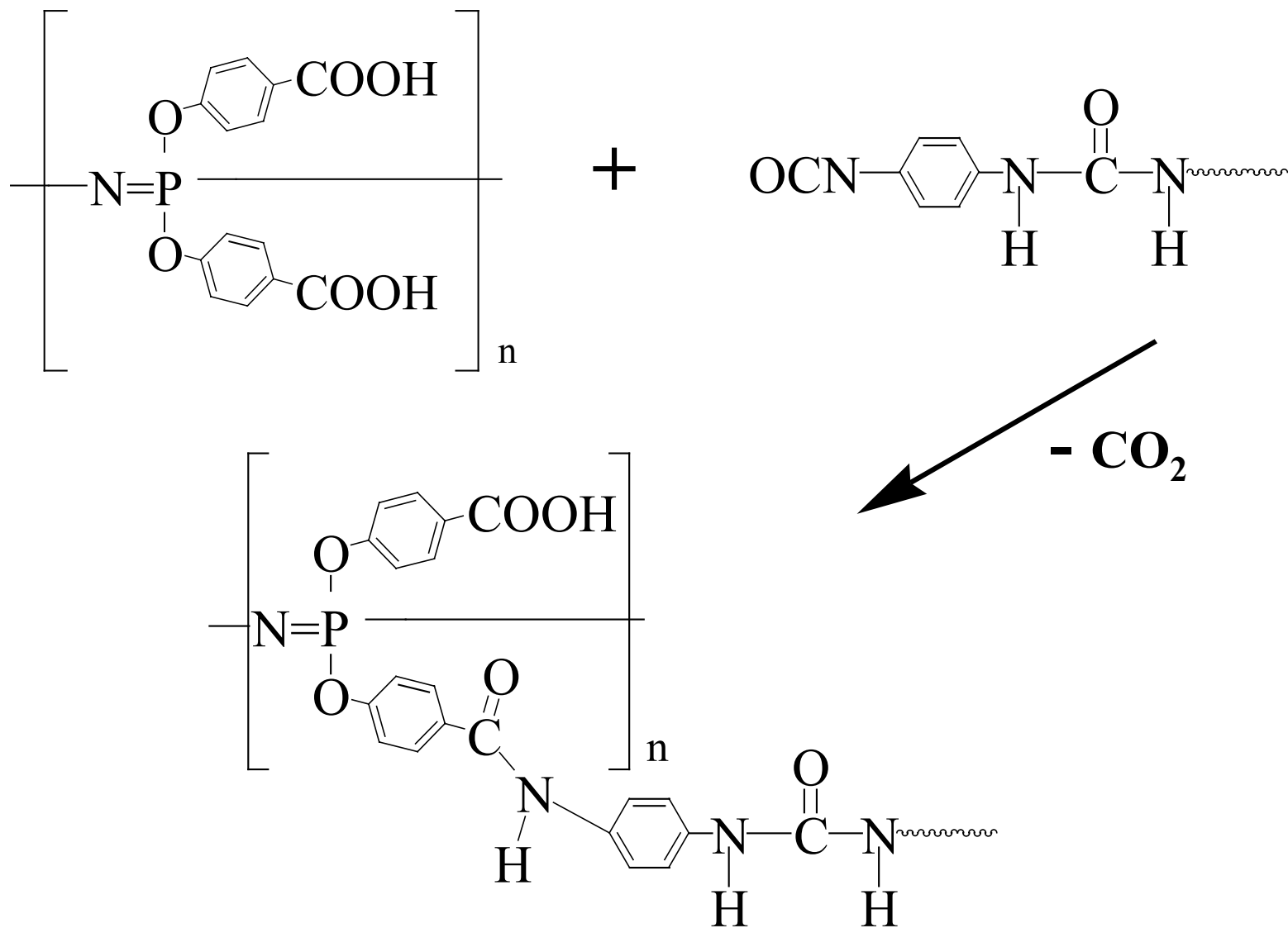



Thermal Analysis

% Phosphazene	% Phosphorus	LOI	Char at 600° C
0	0	20	5
5	0.5	20	10
10	1.0	20	12
20	1.9	21.5	20
30	2.9	23	30



Cyclic Phosphazene - Polyurethane Copolymers

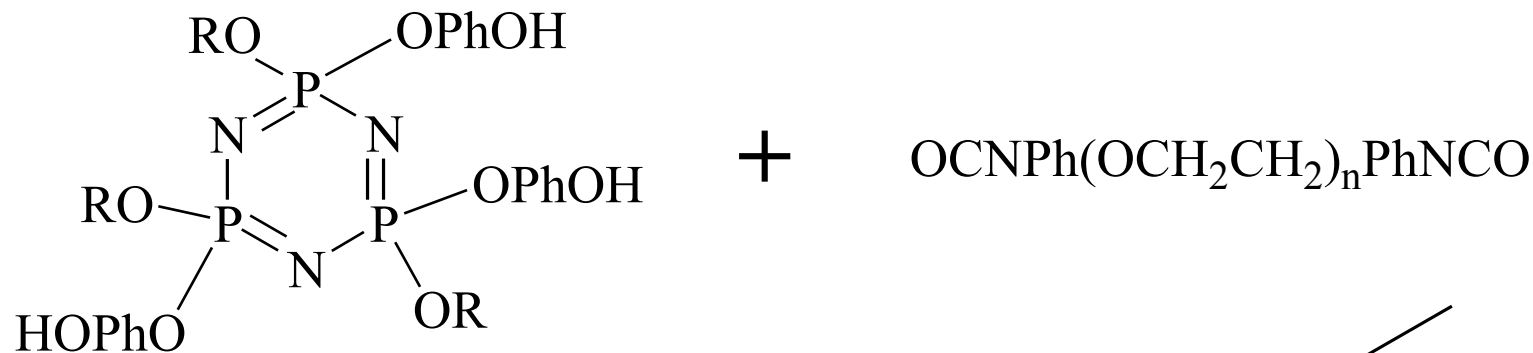

R = Ph, EtOEt,

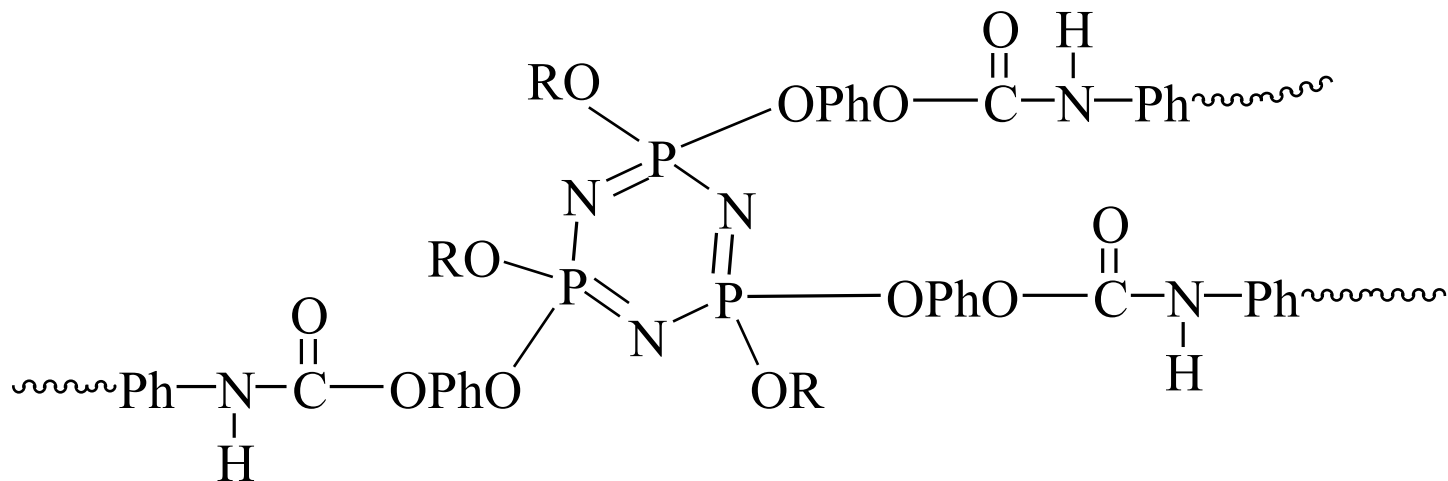



Cyclic Phosphazene-Polyurethane Copolymers

- **Increased crosslinking ability**
- **Covalently bound, non-migrating**
- **Side group tailorability**
- **Low cost**



Thermal Analysis

Polyurethane + $[\text{NP}(\text{OPhOH})(\text{OEtOEt})]_3$

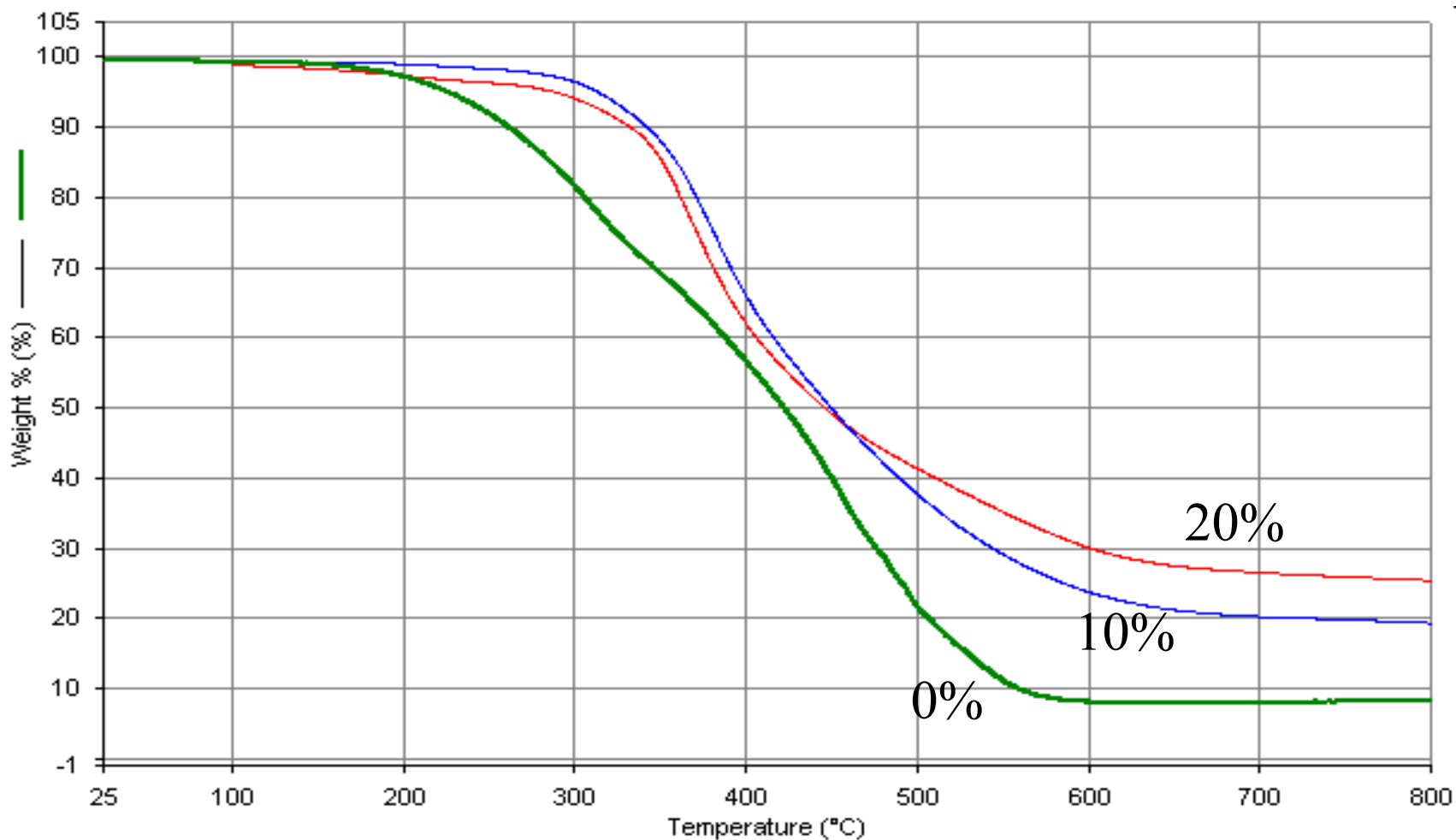



Phosphinimine Chemistry

- **Phosphinimine linkage -P=N-P-**
 - **Synergistic effects**
- **Polymerization of diphenyl-p-styrylphosphine**
 - **Free radical**
 - **Anionic**
 - **Wide range of copolymers possible**
- **Tailorability of phosphazene**



Pendent Phosphazenes

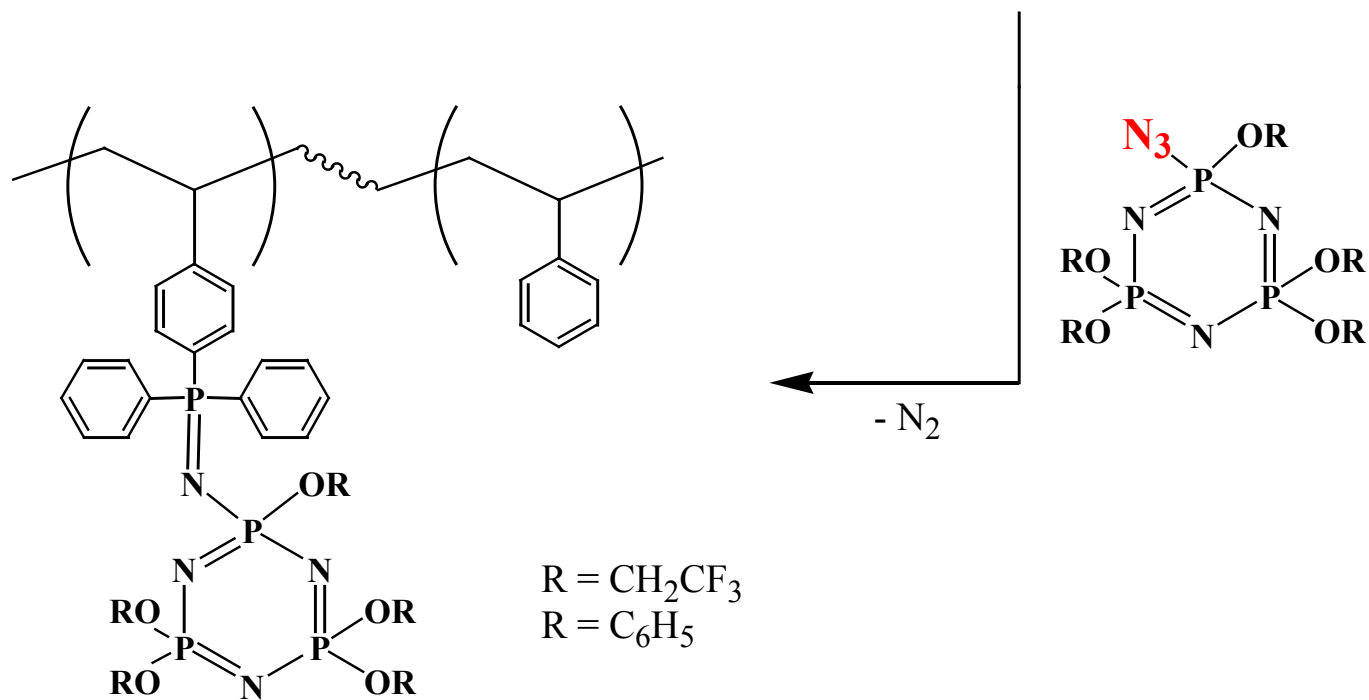
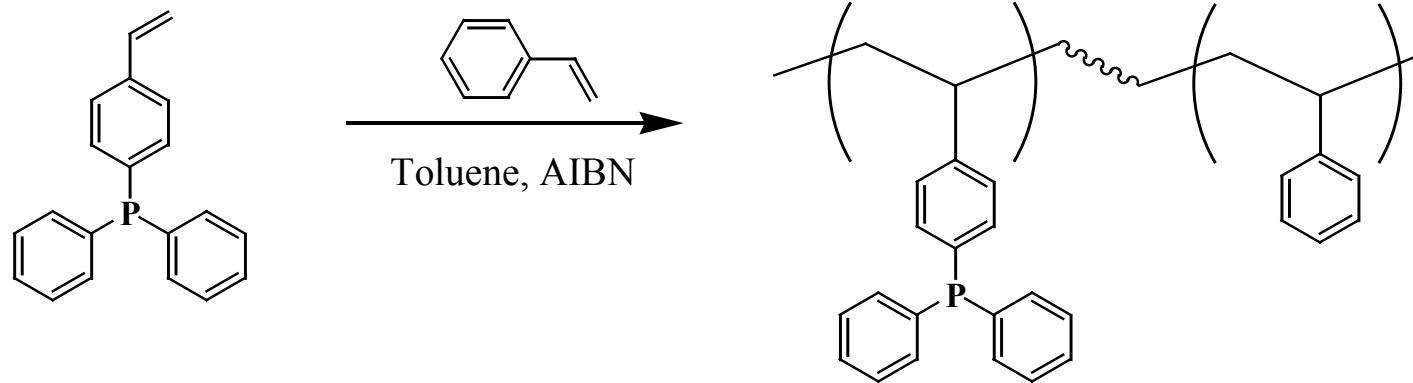



Acyclic Diene Metathesis (ADMET)

- **Intermolecular metathesis of dienes**
- **Ethylene elimination favors high polymers**
- **Catalyst selection, reaction conditions very reactivity and polymer molecular weight**



ADMET for Cyclolinear Phosohazenes

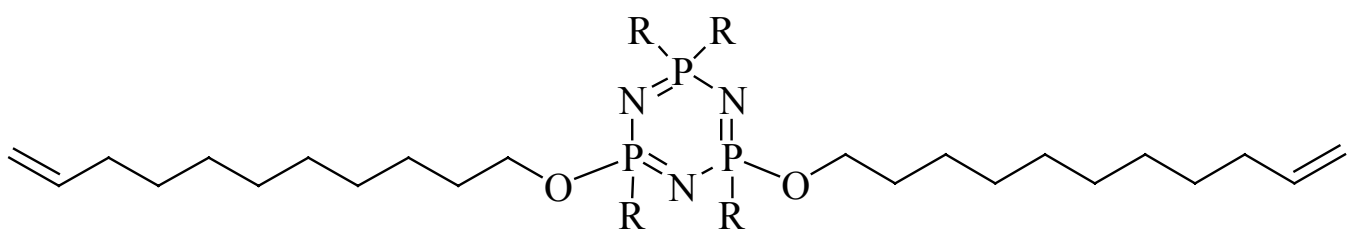
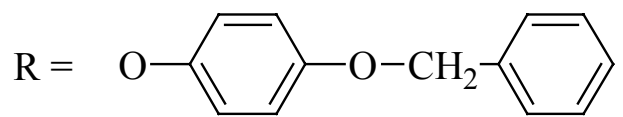
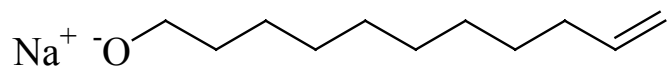
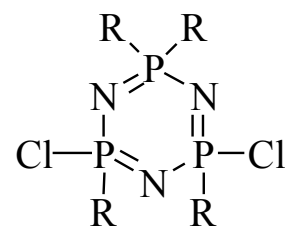
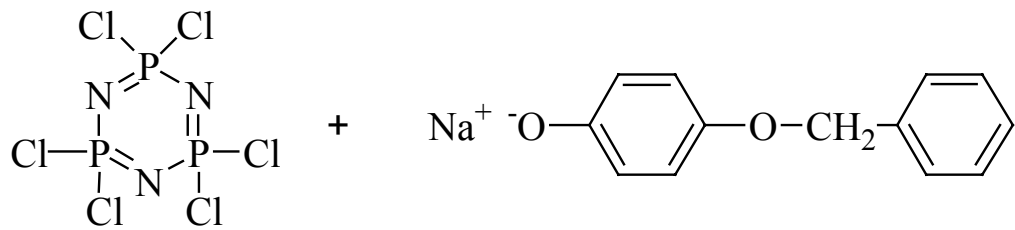



Ring Opening Metathesis Polymerization

- **Ring Opening Metathesis Polymerization – ROMP**
- **Metathesis of strained cyclic olefins**
- **Living polymerization**
- **Wide range of monomers available**



Norbornene-Phosphazene Copolymers

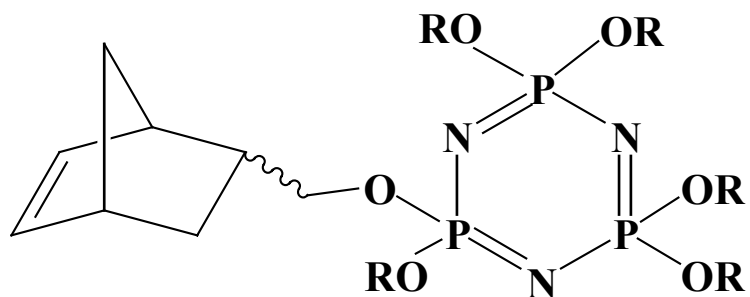

Grubbs Catalyst

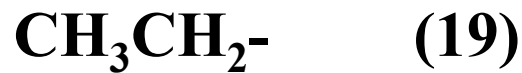
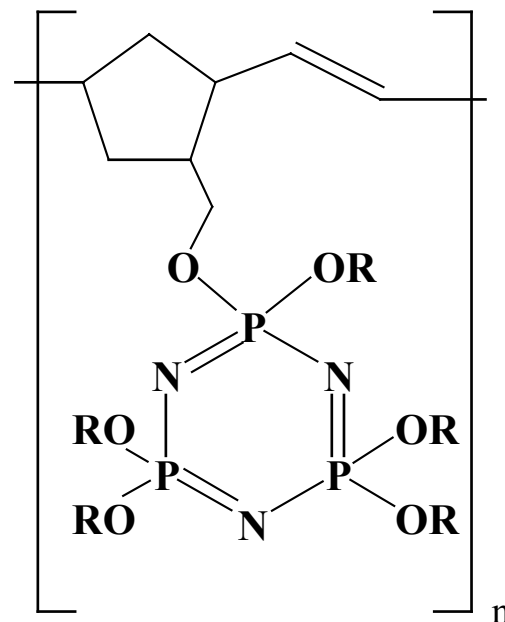



Thermal Analysis

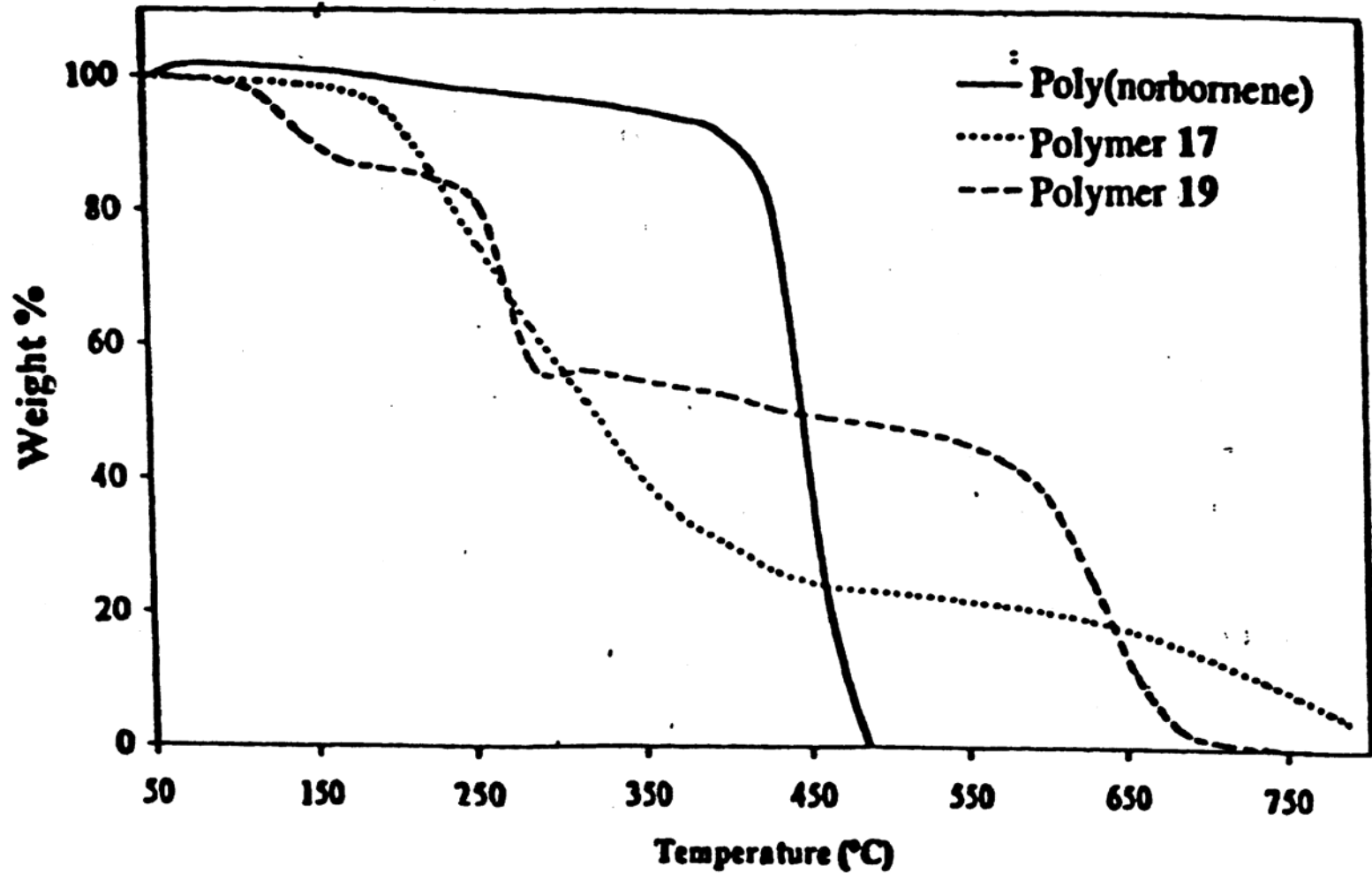



Thermal Analysis

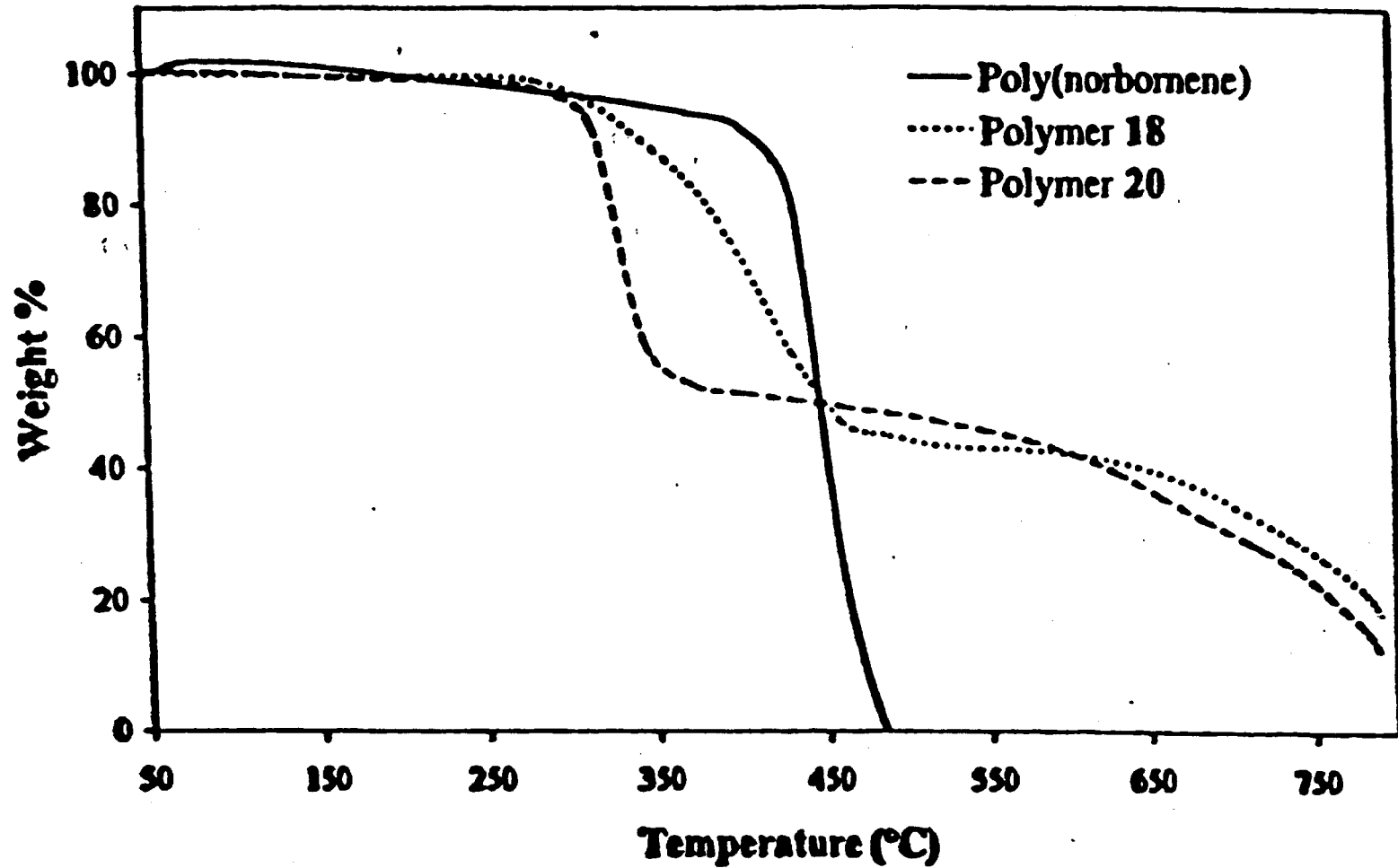



Phosphorylated Phosphazenes

- **Improve fire resistance of polyphosphazenes**
- **Immobilize fire retardant additive onto polymer backbone**
- **Functionalize side groups with phosphate derivatives**

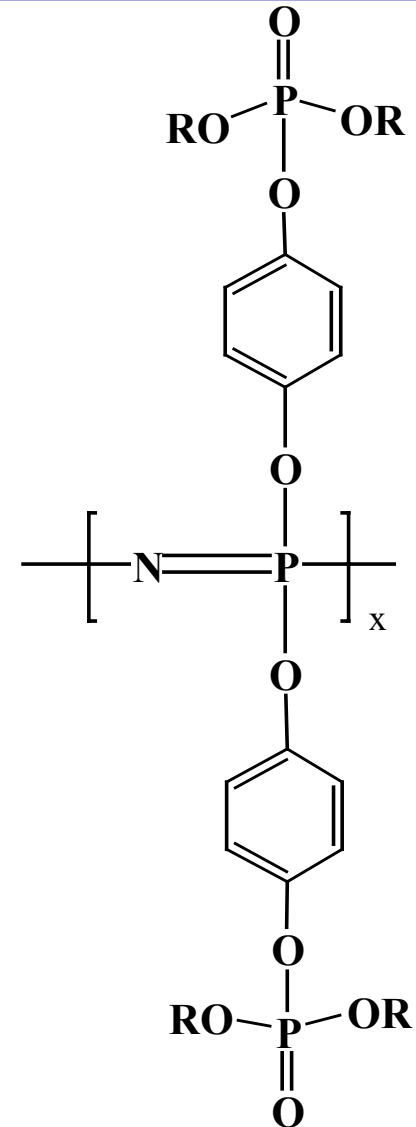



Prepolymer Synthesis

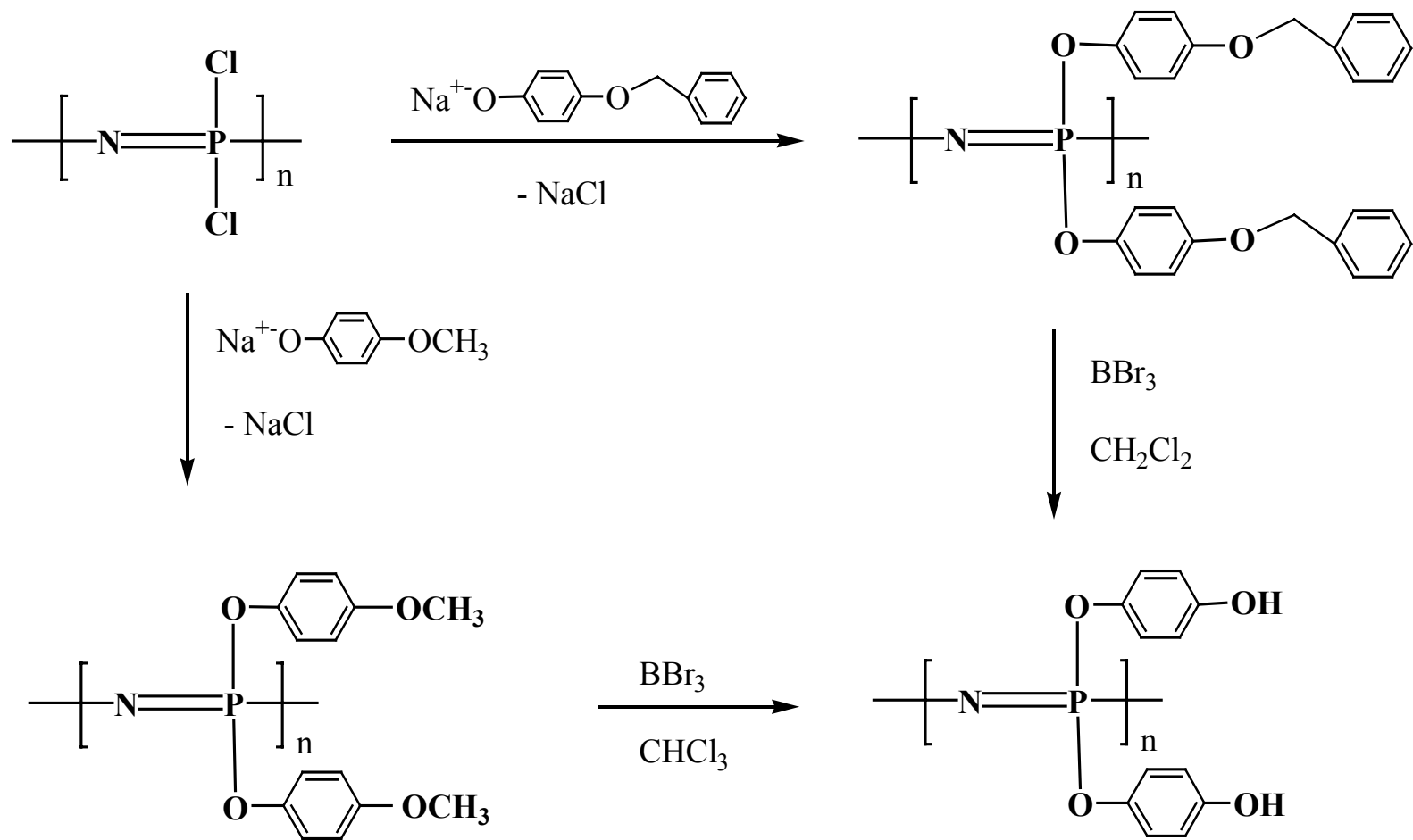



Phosphorylation

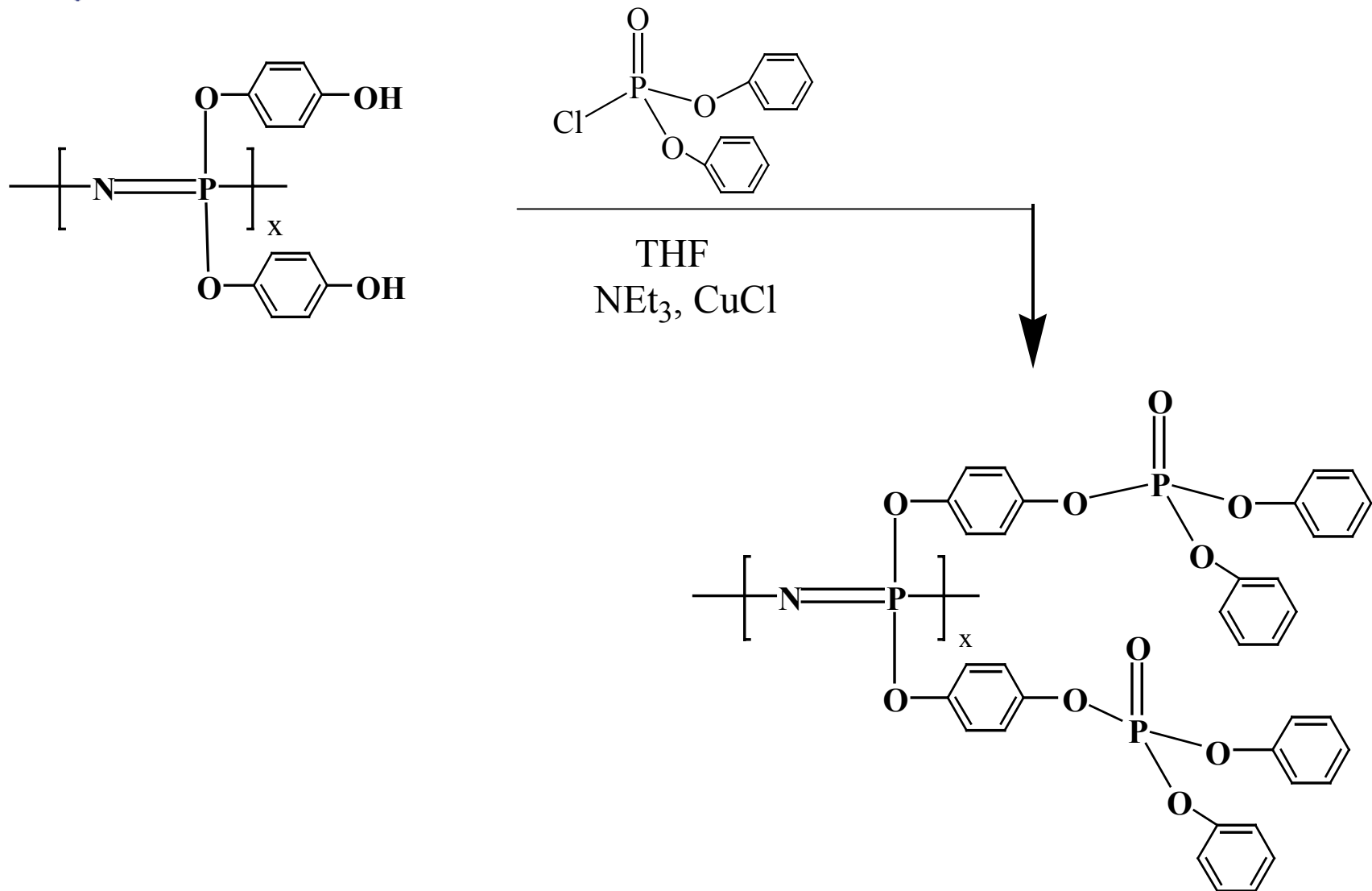



Polystyrene Additives

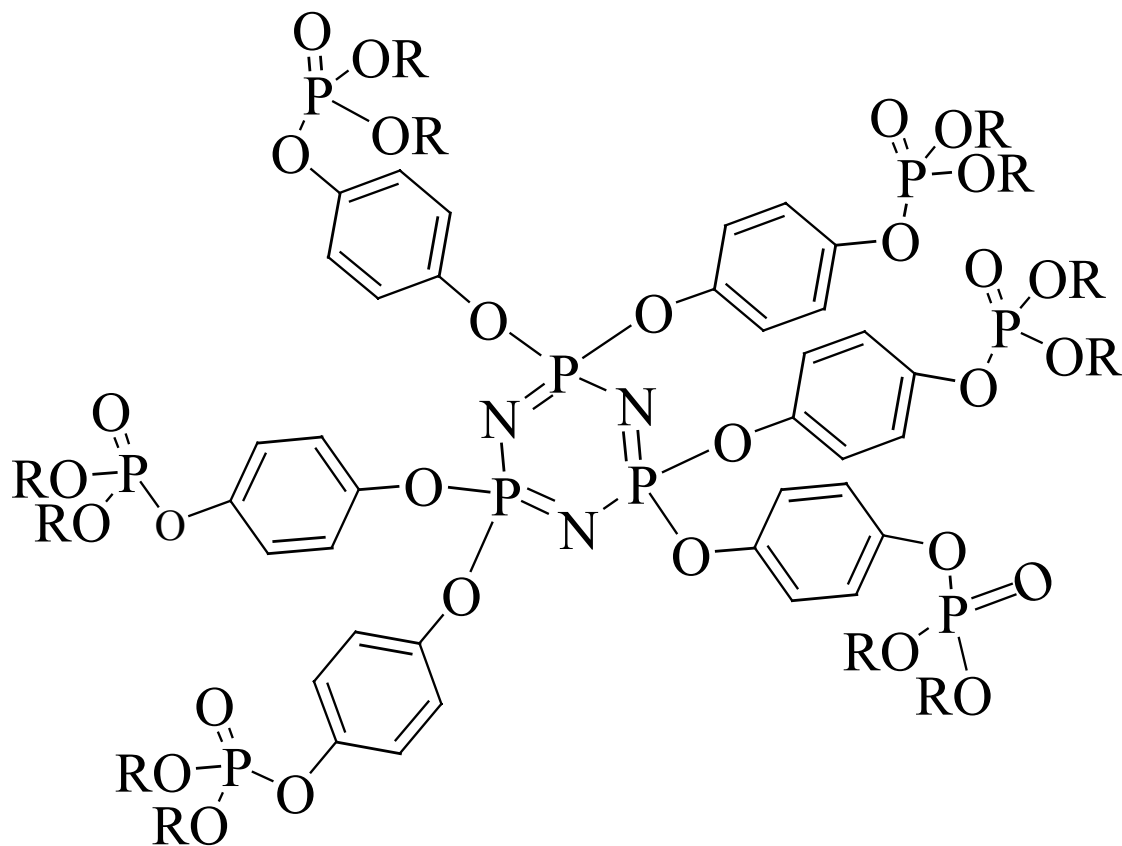

Trimer 1
R = Et

Trimer 2
R = Ph



Thermal Analysis

Additive	Wt %	LOI	% Char at 500 °C
-----	0	18	1
Triphenyl Phosphate	10	22	1
	20	24	1
	30	28	2
Trimer 1 R = Et	10	19	7
	20	20	12
	30	21	17
Trimer 2 R = Ph	10	24	4
	20	26	8
	30	25	15



Phosphazene Poly(ethylene oxide) Block Copolymers

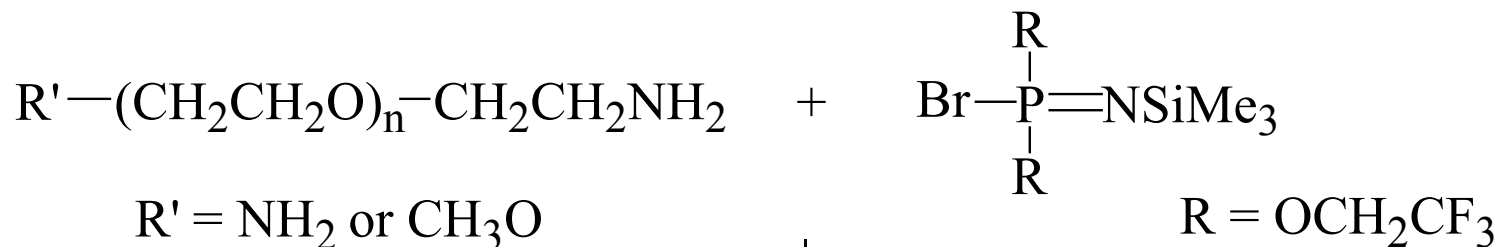

-HBr

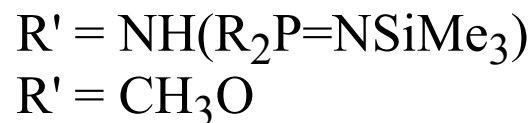

PCl_5

CH_2Cl_2





Block Copolymers, Continued

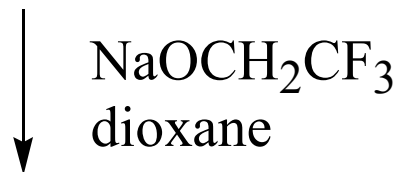
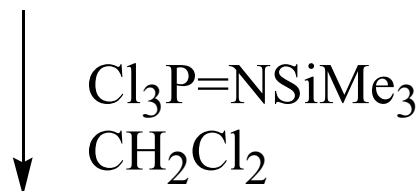



Phosphazene-Styrene Block Copolymers

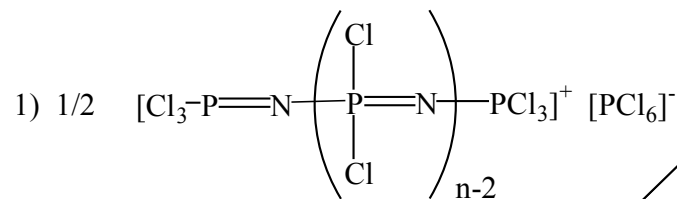
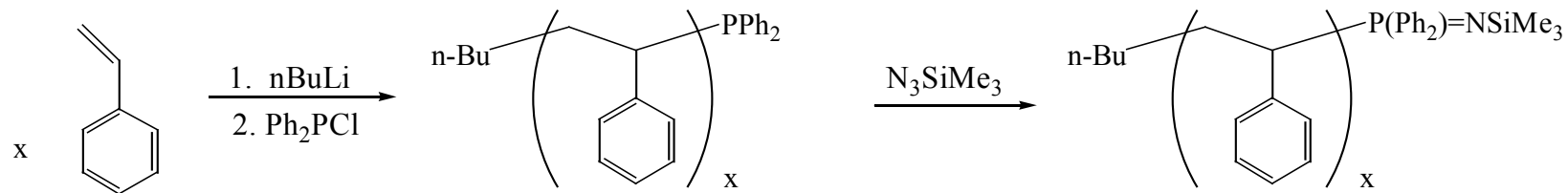

2) NaR

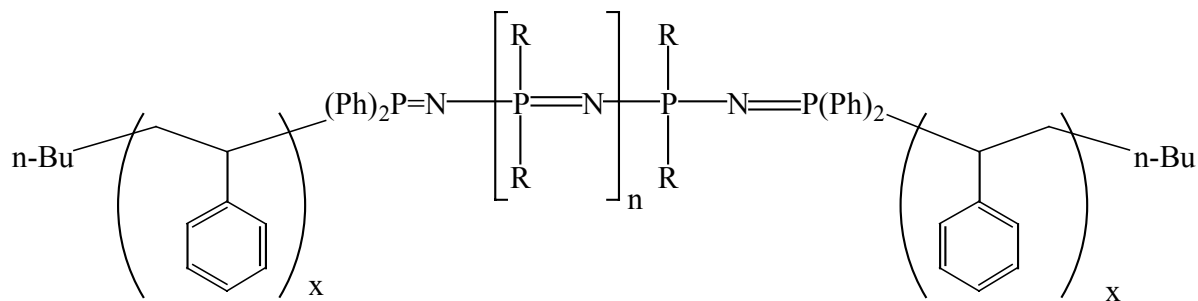

R = OCH₂CF₃



Conclusions and Future Directions

- Phosphazene rings and polymer chains are highly effective fire retardant species
- They function by both vapor phase flame quenching and char formation
- A variety of options have been developed for the incorporation of phosphazene units into polymers both for stand-alone polyphosphazenes and material for blends and IPNs with normal organic polymers
- Future work will involve evaluation of the influence of the phosphazene components on physical properties and fire resistance of blends and IPNs, with a view for minimizing overall materials costs.